

TM 9-2350-292-10
MARINE CORPS TM 07769B-10/1

TECHNICAL MANUAL

OPERATOR'S MANUAL

FOR

**RECOVERY VEHICLE, HEAVY,
FULL-TRACKED: M88A2
(NSN 2350-01-390-4683)
(EIC: ACQ)**

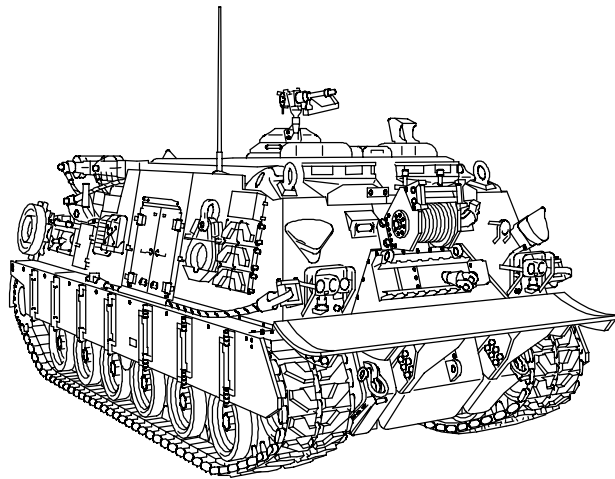

This manual supercedes TM 9-2350-292-10 dated January 2002.
Distribution Statement A: Approved for public release; distribution is unlimited.

01 NOVEMBER 2005
HEADQUARTERS, DEPARTMENT OF THE ARMY
HEADQUARTERS, U.S. MARINE CORPS

WARNING SUMMARY



CARBON MONOXIDE POISONING CAN BE DEADLY.

Carbon monoxide is a colorless, odorless, deadly poisonous gas which, when inhaled, deprives the body of oxygen and causes suffocation. Exposure to air contaminated with carbon monoxide produces symptoms of headache, dizziness, loss of muscular control, apparent drowsiness, and coma. PERMANENT BRAIN DAMAGE or DEATH can result from severe exposure.

Carbon monoxide occurs in the exhaust fumes of fuel-burning heaters and internal-combustion engines. It becomes dangerously concentrated under conditions of inadequate ventilation. The following procedures must be observed to ensure the safety of personnel whenever the personnel heater, main or auxiliary engine of any vehicle is operated for maintenance purposes or tactical use.

1. DO NOT operate heater or engine of vehicle in an enclosed area unless it is ADEQUATELY VENTILATED.
2. DO NOT idle engine for long periods without maintaining adequate ventilation in personnel compartments.
3. DO NOT drive any vehicle with inspection plates, cover plates or engine compartment doors removed unless necessary for maintenance purposes.
4. BE ALERT at all times during vehicle operation for exhaust odors and exposure symptoms. If either are present, immediately ventilate personnel compartments. If symptoms persist, remove affected personnel from vehicle and treat as follows: expose to fresh air; keep warm; do not permit physical exercise; if necessary, administer artificial respiration.

THE BEST DEFENSE AGAINST CARBON MONOXIDE POISONING IS ADEQUATE VENTILATION.

WARNING

CO₂ fire extinguisher can cause suffocation and severe burns. Exit vehicle immediately after discharging fire extinguisher. Handle fire extinguisher carefully. Do not bang or drop the cylinder. Failure to comply may result in injury or DEATH to personnel.

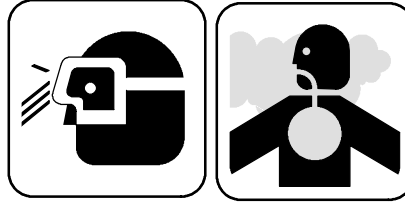

Adhesives, solvents, and sealing compounds can burn easily, can give off harmful vapors, and are harmful to skin and clothing. To avoid injury or death, keep away from open flame and use only in well-ventilated area. If adhesive, solvent, or sealing compound get on skin or clothing, wash immediately with soap and water.

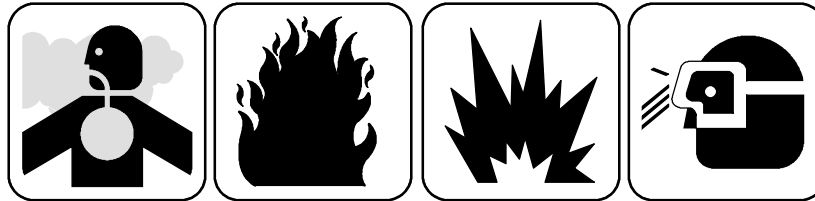

Dry-cleaning solvent P-D-680 is toxic and flammable. Wear protective goggles and gloves and use only in a well-ventilated area. Avoid contact with skin, eyes, and clothes and do not breathe the vapors. Do not use near open flame or excessive heat. If you become dizzy while using dry-cleaning solvent, get fresh air immediately and get medical aid. If contact with eyes is made, wash your eyes with water and get medical aid immediately.

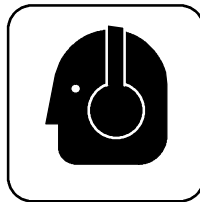

SINGLE HEARING PROTECTION REQUIRED

Wear hearing protection during engine and/or APU operations. Also when operating the vehicle up to a speed of 20 mph. Single hearing protection includes earplugs, earmuffs, attenuating Combat Vehicle Crewman (CVC) helmet, or headset. Failure to wear hearing protection can result in hearing damage.

Wear hearing protection when firing the M2 machine gun.

DOUBLE HEARING PROTECTION REQUIRED

Wear double hearing protection when operating the vehicle over a speed of 20 mph. Double hearing protection consists of wearing earplugs or earmuffs with either an attenuating CVC helmet or headset. Failure to wear hearing protection can result in hearing damage.

WARNING



After Nuclear, Biological, or Chemical (NBC) exposure of this vehicle, all air filters shall be handled with extreme caution. Unprotected personnel may experience injury or DEATH if residual toxic agents or radioactive materials are present. If vehicle is exposed to chemical or biological agents, servicing personnel shall wear protective mask, hood, protective overgarments, and chemical protective gloves and boots. All contaminated air filters shall be placed into double-lined plastic bags and swiftly moved to a segregation area away from the work site. The same procedure applies for radioactive dust contamination; however, the NBC team should measure the radiation prior to filter removal to determine the extent of safety procedures required per the NBC Annex to the Standard Operating Procedures (SOP). The segregation area in which the contaminated air filters are temporarily stored shall be marked with appropriate NBC placards. Final disposal of contaminated air filters shall be in accordance with local SOP.

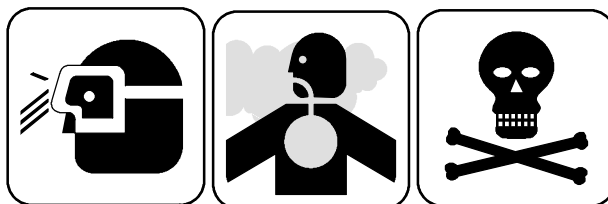

Chemical Agent Resistant Coating (CARC) paint contains isocyanate (HDI) which is highly irritating to skin and respiratory system. High concentrations of HDI can produce symptoms of itching and red- dening of skin, a burning sensation in throat and nose, and watering of the eyes. In extreme concen- trations, HDI can cause cough, shortness of breath, pain during respiration, increased sputum pro- duction, and chest tightness. The following precautions must be taken whenever using CARC paint:

ALWAYS use air line respirators when using CARC paint unless air sampling shows exposure to be below hazardous level threshold standards. Use chemical cartridge respirator, if air sampling is above standards.



DO NOT allow skin or eyes to come in contact with CARC paint. Always wear protective equipment (gloves, ventilation mask, safety goggles, etc).

DO NOT use CARC paint without adequate ventilation.

NEVER weld or cut CARC coated materials.

DO NOT grind or sand painted equipment without high-efficiency air purifying respirators in use.

BE AWARE of CARC paint exposure symptoms; symptoms can occur a few days after initial expo- sure. Seek medical help immediately if symptoms are detected.

WARNING



HIGH VOLTAGE

is used in the operation of some equipment.

DEATH ON CONTACT

may result if personnel fail to observe safety precautions.

Never work on electronic equipment unless at least one other person familiar with the operation and hazards of the equipment is nearby. That person should also be competent in giving first aid. When an operator helps a technician, that operator must be warned about dangerous areas.

Shut off power supply to equipment before beginning work. When working inside equipment with power off, take special care to ground every capacitor likely to hold a dangerous potential.

Be careful not to contact high-voltage connections when installing or operating this equipment.

Remove rings, bracelets, wristwatches, and neck chains before working on any vehicle. Jewelry can catch on equipment and cause injury, or may short across an electrical circuit causing severe burns or electrical shock.



Keep one hand away from the equipment to reduce the hazard of current flowing through life-sustaining organs of the body.

Overhead power lines can cause electrical shock and damage to equipment. Tie down antennas before driving under overhead power lines. Failure to comply may result in injury or DEATH to personnel.

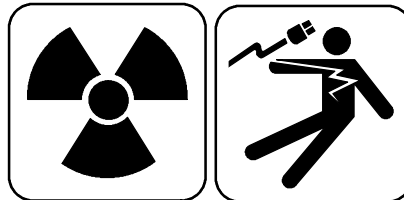

Radio antennas can radiate harmful levels of radio frequency energy. Remain at least two feet from radiating antennas of vehicle-mounted radios. Failure to comply may result in personnel injury.

WARNING



Use two personnel to guide driver when backing the vehicle for emplacement or any other reason. Failure to comply may result in injury or DEATH to personnel or damage to equipment.

Do not stand between vehicles while one or more of them are moving. Vehicle could jump and pin you against the other vehicle. Failure to comply may result in injury or DEATH to personnel.

When adjustment or service requires a running engine, two personnel will be used; one at the vehicle controls and the other at the service point. This helps prevent accidental movement of controls. Failure to comply may result in injury or DEATH to personnel.

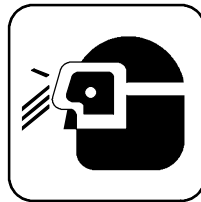

Use care when cutting lockwire. Wire can act as a projectile when cut and could cause severe eye injury.

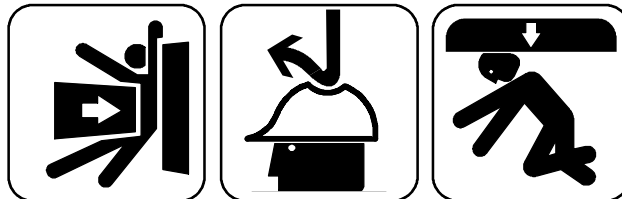

FALLING EQUIPMENT HAZARD

NEVER crawl under equipment when performing maintenance unless equipment is securely blocked. Equipment may fall and cause serious injury or DEATH to personnel.

KEEP CLEAR of equipment when equipment is being raised or lowered. Equipment may fall and cause serious injury or DEATH to personnel.

DO NOT work on equipment supported only by lift jacks or hoist. Always use blocks or proper stands to support item prior to any work. Equipment may fall and cause severe injury or DEATH to personnel.

EXTREME CAUTION is necessary when working near a wire rope under tension. A snapped wire rope, shifting or swinging load may result in injury or DEATH to personnel.

WARNING



Fuel is very flammable and can explode easily. To avoid serious injury or DEATH, keep fuel away from open flame or extreme heat. Always keep fire extinguisher within easy reach when working with fuel. Do not work on fuel system when engine is hot. Fuel can be ignited by hot engine. When working with fuel, post signs that read “NO SMOKING WITHIN 50 FEET OF VEHICLE”.

Fuel and oil are slippery and can cause falls. To avoid injury, wipe up spilled fuel or oil immediately with rags. Dispose of fuel-soaked rags in accordance with unit policy.



Hatches could close and injure or KILL personnel. Visually check inside and outside locks of hatches for latching before operating vehicle in open hatch mode.

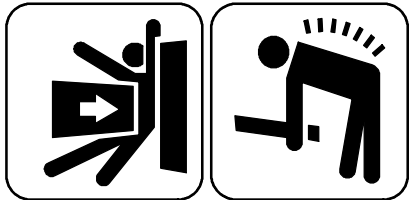

To avoid personal injury, use an assistant when lifting parts or components that weigh more than 40 lbs (23 kg). Failure to comply may cause injury to personnel.



When breaking track stand clear. End connector may fly and strike nearby personnel. Failure to comply may result in injury to personnel.

Flying objects may strike nearby personnel and cause injury.

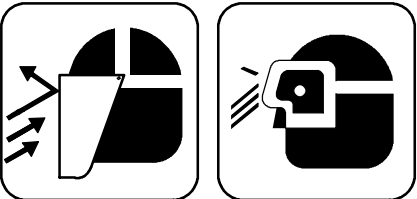

COMPRESSED AIR HAZARD

Compressed air used for cleaning purposes will not exceed 30 psi (207 kPa). Use only with effective chip guarding and personal protective equipment (goggles/shield, gloves, etc.).

WARNING



Always use “three point contact” with vehicle; face vehicle when entering or leaving cab. Three point contact means that three out of four arms and legs are in contact with the vehicle at all times during mount or dismount. Failure may result in injury to personnel.

Clean shoes and wipe hands before climbing onto vehicle and use grab handles. Failure to comply may result in injury to personnel.

Never use control levers as a hand-hold when climbing on or off. Never step on foot controls when mounting or climbing off vehicle. Failure to comply may result in injury or DEATH to personnel.

Never enter a moving vehicle. Failure to comply may result in injury or DEATH to personnel.

Do not use equipment for purpose other than its intended use, unless authorized by the National Inventory Control Point (NICP)/commodity command. Failure to comply may result in injury to personnel or equipment damage.



BURN HAZARD

Allow engine to cool before performing maintenance on the muffler, exhaust pipe, exhaust manifold, or turbocharger. If necessary, use insulated pads or gloves.

Do not touch hot exhaust system with bare hands; injury to personnel will result.

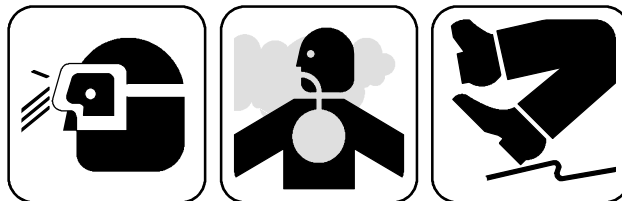

Never disconnect any hydraulic line or fitting without first dropping pressure to zero. High-pressure hydraulics operate this equipment. Refer to vehicle operator and maintenance manuals for hydraulic oil pressure. A high-pressure oil stream can pierce body and cause severe injury to personnel.

Diesel or hydraulic fluid leaks under pressure may not be visible. Use a piece of wood or cardboard to find leaks, DO NOT use a bare hand. Wear safety goggles for protection. Failure to comply may result in injury to personnel.

REFER TO FM 21-11, “FIRST AID FOR SOLDIERS”, FOR CORRECT PROCEDURES TO BE TAKEN IF A CREWMEMBER IS INJURED.

WARNING

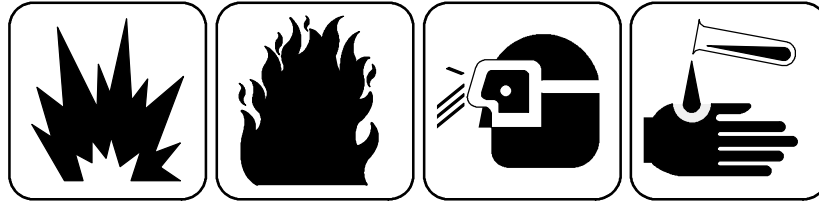

BATTERY HAZARD

Lead-acid gasses can explode. Do not smoke, have open flames, or make sparks around a battery, especially if caps are off. If a battery is gassing, it can explode and cause injury to personnel.

- a. Ventilate when charging or using in an enclosed space.
- b. Wear safety goggles and acid-proof gloves when battery cover must be removed or when adding electrolyte.
- c. Avoid electrolyte contact with skin, eyes, or clothing. If battery electrolyte spills, take immediate action to stop burning effects:
 - External: immediately flush with cold running water to remove all acid.
 - Eyes: Flush with cold water for at least 15 minutes. Seek immediate medical attention.
 - Internal: Drink large amounts of water or milk. Follow with milk of magnesia, beaten egg, or vegetable oil. Seek immediate medical attention.
 - Clothing or Vehicle: Wash at once with cold water. Neutralize with baking soda or household ammonia solution.

Vehicle operation in hot weather can increase the risk of heat stress to crew members. Follow individual preventive medicine measures in FM 21-10 to reduce the risk of heat stress in armored vehicles.

INSERT LATEST CHANGED PAGES/WORK PACKAGES. DESTROY SUPERSEDED DATA

LIST OF EFFECTIVE PAGES/WORK PACKAGES

Note: The portion of the text affected by the changes is indicated by a vertical line in the outer margin of the page. Changes to illustrations are indicated by miniature pointing hands. Changes to wiring diagrams are indicated by shaded areas.

Date of issue for original and changed pages/work packages are:

Original 001 NOVEMBER 2005

TOTAL NUMBER OF PAGES FOR FRONT AND REAR MATTER IS **28**. TOTAL NUMBER OF WORK PACKAGES IS **136** CONSISTING OF THE FOLLOWING:

Page No.	*Change No.	Page No.	*Change No.	Page No.	*Change No.
Cover	0	WP 0031 00 (2 pages)	0	WP 0068 00 (2 pages)	0
Blank	0	WP 0032 00 (2 pages)	0	WP 0069 00 (2 pages)	0
a – h	0	WP 0033 00 (2 pages)	0	WP 0070 00 (2 pages)	0
A - B	0	WP 0034 00 (2 pages)	0	WP 0071 00 (6 pages)	0
i - vi	0	WP 0035 00 (2 pages)	0	WP 0072 00 (4 pages)	0
WP 0001 00 (4 pages).....	0	WP 0036 00 (2 pages)	0	WP 0073 00 (2 pages)	0
Chapter 1 Title Page.....	0	WP 0037 00 (2 pages)	0	WP 0074 00 (4 pages)	0
WP 0002 00 (2 pages).....	0	WP 0038 00 (2 pages)	0	WP 0075 00 (2 pages)	0
WP 0003 00 (12 pages).....	0	WP 0039 00 (2 pages)	0	WP 0076 00 (2 pages)	0
WP 0004 00 (2 pages).....	0	WP 0040 00 (4 pages)	0	WP 0077 00 (4 pages)	0
WP 0005 00 (16 pages).....	0	WP 0041 00 (4 pages)	0	WP 0078 00 (2 pages)	0
Chapter 2 Title Page.....	0	WP 0042 00 (2 pages)	0	WP 0079 00 (2 pages)	0
WP 0006 00 (16 pages).....	0	WP 0043 00 (6 pages)	0	WP 0080 00 (2 pages)	0
WP 0007 00 (4 pages).....	0	WP 0044 00 (6 pages)	0	WP 0081 00 (2 pages)	0
WP 0008 00 (4 pages).....	0	WP 0045 00 (4 pages)	0	WP 0082 00 (2 pages)	0
WP 0009 00 (2 pages).....	0	WP 0046 00 (2 pages)	0	WP 0083 00 (2 pages)	0
WP 0010 00 (2 pages).....	0	WP 0047 00 (16 pages)	0	WP 0084 00 (4 pages)	0
WP 0011 00 (4 pages).....	0	WP 0048 00 (4 pages)	0	Chapter 3 Title Page	0
WP 0012 00 (4 pages).....	0	WP 0049 00 (2 pages)	0	WP 0085 00 (2 pages)	0
WP 0013 00 (2 pages).....	0	WP 0050 00 (4 pages)	0	WP 0086 00 (4 pages)	0
WP 0014 00 (4 pages).....	0	WP 0051 00 (12 pages)	0	WP 0087 00 (2 pages)	0
WP 0015 00 (4 pages).....	0	WP 0052 00 (8 pages)	0	WP 0088 00 (2 pages)	0
WP 0016 00 (4 pages).....	0	WP 0053 00 (6 pages)	0	WP 0089 00 (2 pages)	0
WP 0017 00 (2 pages).....	0	WP 0054 00 (6 pages)	0	WP 0090 00 (4 pages)	0
WP 0018 00 (2 pages).....	0	WP 0055 00 (2 pages)	0	WP 0091 00 (2 pages)	0
WP 0019 00 (2 pages).....	0	WP 0056 00 (2 pages)	0	WP 0092 00 (2 pages)	0
WP 0020 00 (2 pages).....	0	WP 0057 00 (6 pages)	0	WP 0093 00 (2 pages)	0
WP 0021 00 (2 pages).....	0	WP 0058 00 (2 pages)	0	WP 0094 00 (2 pages)	0
WP 0022 00 (2 pages).....	0	WP 0059 00 (2 pages)	0	WP 0095 00 (2 pages)	0
WP 0023 00 (2 pages).....	0	WP 0060 00 (2 pages)	0	WP 0096 00 (2 pages)	0
WP 0024 00 (2 pages).....	0	WP 0061 00 (2 pages)	0	WP 0097 00 (2 pages)	0
WP 0025 00 (2 pages).....	0	WP 0062 00 (2 pages)	0	WP 0098 00 (2 pages)	0
WP 0026 00 (2 pages).....	0	WP 0063 00 (2 pages)	0	WP 0099 00 (2 pages)	0
WP 0027 00 (2 pages).....	0	WP 0064 00 (2 pages)	0	WP 0100 00 (2 pages)	0
WP 0028 00 (2 pages).....	0	WP 0065 00 (2 pages)	0	WP 0101 00 (2 pages)	0
WP 0029 00 (2 pages).....	0	WP 0066 00 (4 pages)	0	WP 0102 00 (2 pages)	0
WP 0030 00 (2 pages).....	0	WP 0067 00 (8 pages)	0	WP 0103 00 (2 pages)	0

*Zero in this column indicates an original page

TM 9-2350-292-10

Page No.	*Change No.	Page No.	*Change No.	Page No.	*Change No.
WP 0104 00 (4 pages).....	0	WP 0135 00 (4 pages)	0		
Chapter 4 Title Page.....	0	WP 0136 00 (18 pages)	0		
WP 0105 00 (114 pages).....	0	Index-1 - Index-5/6 Blank	0		
WP 0106 00 (6 pages).....	0	DA Form 2028 Sample (Pt 1)..	0		
WP 0107 00 (6 pages).....	0	DA Form 2028 Sample (Pt 2)..	0		
WP 0108 00 (4 pages).....	0	DA Form 2028 (Pt 1)	0		
WP 0109 00 (4 pages).....	0	DA Form 2028 (Pt 2)	0		
WP 0110 00 (2 pages).....	0	Conversion Table	0		
WP 0111 00 (2 pages).....	0	Blank.....	0		
WP 0112 00 (2 pages).....	0	Measurement Page	0		
WP 0113 00 (4 pages).....	0	PIN Page	0		
WP 0114 00 (2 pages).....	0				
WP 0115 00 (4 pages).....	0				
WP 0116 00 (4 pages).....	0				
WP 0117 00 (2 pages).....	0				
WP 0118 00 (2 pages).....	0				
WP 0119 00 (2 pages).....	0				
WP 0120 00 (2 pages).....	0				
WP 0121 00 (2 pages).....	0				
WP 0122 00 (2 pages).....	0				
WP 0123 00 (2 pages).....	0				
WP 0124 00 (2 pages).....	0				
WP 0125 00 (2 pages).....	0				
WP 0126 00 (2 pages).....	0				
WP 0127 00 (2 pages).....	0				
WP 0128 00 (2 pages).....	0				
WP 0129 00 (2 pages).....	0				
WP 0130 00 (2 pages).....	0				
WP 0131 00 (2 pages).....	0				
Chapter 5 Title Page	0				
WP 0132 00 (4 pages).....	0				
WP 0133 00 (20 pages).....	0				
WP 0134 00 (2 pages).....	0				

*Zero in this column indicates an original page

MARINE CORPS TM 07769B-10-1

HEADQUARTERS
DEPARTMENT OF THE ARMY
U.S. MARINE CORPS
WASHINGTON, D.C. 01 NOV 2005

TECHNICAL MANUAL

OPERATOR'S MANUAL

RECOVERY VEHICLE, HEAVY, FULL-TRACKED: M88A2
NSN 2350-01-390-4683 (EIC: ACQ)

REPORTING OF ERRORS AND RECOMMENDING IMPROVEMENTS

You can help improve this publication. If you find any mistakes or if you know of a way to improve the procedures, please let us know. Submit your DA Form 2028 (Recommended Changes to Equipment Technical Publications), through the Internet, on the Army Electronic Product Support (AEPS) website. The Internet address is <http://aeps.ria.army.mil>. The DA Form 2028 is located under the Public Applications section in the AEPS Public Home Page. Fill out the form and click on SUBMIT. Using this form on the AEPS will enable us to respond quicker to your comments and better manage the DA Form 2028 program. You may also mail, fax or email your letter or DA Form 2028 direct to: AMSTA-LC-LMIT / TECH PUBS, TACOM-RI, 1 Rock Island Arsenal, Rock Island, IL 61299-7630. The email address is TACOM-TECH-PUBS@ria.army.mil. The fax number is DSN 793-0726 or Commercial (309) 782-0726.

Marine Corps users submit NAVMC Form 10772 directly to: Commanding General, Marine Corps Logistics Base (Code 850), Albany, GA 31704-5000.

A reply will be furnished directly to you.

TABLE OF CONTENTS

WP Sequence No.

WARNING SUMMARY

HOW TO USE THIS MANUAL

General Information 0001 00

CHAPTER 1 - DESCRIPTION AND THEORY OF OPERATION

Equipment Characteristics, Capabilities and Features 0002 00

Location and Description of Major Components 0003 00

Equipment Data 0004 00

Theory of Operation 0005 00

CHAPTER 2 - OPERATOR INSTRUCTIONS

Description and Use of Operator's Controls and Indicators 0006 00

Description and Use of Mechanic's Controls and Indicators 0007 00

Description and Use of Commander's Controls and Indicators 0008 00

Description and Use of Personnel Controls and Indicators 0009 00

DISTRIBUTION STATEMENT A: - APPROVED FOR PUBLIC RELEASE; DISTRIBUTION IS UNLIMITED.

*Supersedes TM 9-2350-292-10 dated 1 January 2002.

TABLE OF CONTENTS - CONTINUED

WP Sequence No.

CHAPTER 2 - OPERATOR INSTRUCTIONS - CONTINUED

OPERATION UNDER USUAL CONDITIONS

Assembly and Preparation for Use	0010 00
Engine Prestart Operation	0011 00
Starting Main Engine	0012 00
Normal Engine Operation	0013 00
Transmission Shift Selection	0014 00
Steering Instructions	0015 00
Driving the Vehicle	0016 00
Stop the Vehicle	0017 00
Backing the Vehicle	0018 00
Shutdown Main Engine	0019 00
Operate Fuel Control Valves	0020 00
Operate Dome Light	0021 00
Operate Rear Service Lights	0022 00
Operate Light Switch Assembly	0023 00
Operate Hull and Crew Compartment Doors	0024 00
Operate Commander's Cupola	0025 00
Operate Operator's, Mechanic's and Personnel Hatch	0026 00
Operate Storage Compartment Door, Left Side Hull	0027 00
Operate Storage Compartment Door, Right Side Hull	0028 00
Operate Hoist Winch Cable Access Door	0029 00
Operate APU Compartment Door	0030 00
Operate Engine Deck Door	0031 00
Operate Rear Engine Deck Exhaust Grille and Exhaust Deflector	0032 00
Operate Front Engine Deck Grille	0033 00
Operate Engine Deck Side Grille	0034 00
Operate Engine Deck Access Door	0035 00
Operate Subfloor Access Plates and Doors	0036 00
Adjusting Operator's and Mechanic's Seat	0037 00
Adjusting Commander's Seat	0038 00
Operate Auxiliary Boom	0039 00
Towing Operation	0040 00
Tow Disabled Vehicle	0041 00
Operate Pintle	0042 00
Operate Tow Bar	0043 00
Operate Tow Cables	0044 00
Preparing Hydraulic System for Operation	0045 00
Operate Spade	0046 00
Operate Boom	0047 00
Operate Hoist Winch	0048 00
Operate Auxiliary Winch	0049 00
Operate Main Winch	0050 00
Vehicle Recovery Operations	0051 00
Decals and Instruction Plates	0052 00

OPERATE AUXILIARY EQUIPMENT

Operate Auxiliary Power Unit	0053 00
Refuel and Defuel Operation	0054 00
Operate Impact Wrench	0055 00

TABLE OF CONTENTS - CONTINUED

WP Sequence No.

CHAPTER 2 - OPERATOR INSTRUCTIONS - CONTINUED

OPERATE AUXILIARY EQUIPMENT - CONTINUED

Operate Personnel Heater	0056 00
Operate Personnel Heater (Global A20)	0057 00
Operate Ventilating Blower	0058 00
Operate Passive Night Viewer	0059 00
Operate Driver's Viewer Enhancer	0060 00
Operate Portable Fire Extinguishers	0061 00
Operate Fixed Fire Extinguisher System (FES)	0062 00
Operate Vehicle Jack	0063 00
Operate Outside Spotlight	0064 00
Operate Trouble Light	0065 00
Operate Welding Equipment (Acetylene/Oxygen)	0066 00
Operate Welding Equipment (Exothermic Cutter)	0067 00
Operate Gas Particulate Filter Unit and M3 NBC Heater	0068 00
Operate .50 Caliber Machine Gun Mount	0069 00
Operate Communications System	0070 00
Operate M239 Smoke Grenade System	0071 00
Operate Exhaust Smoke Generating System	0072 00

PREPARATION FOR MOVEMENT

Preparation For Movement	0073 00
--------------------------------	---------

OPERATION UNDER UNUSUAL CONDITIONS

Slave Start	0074 00
Towed Start	0075 00
Extreme Cold Weather Operation +32°F to -25°F (0°C to -31°C)	0076 00
Starting Main Engine in Cold Weather Below +32°F to -25°F (0°C to -31°C)	0077 00
Parking Vehicle in Extreme Cold Weather +32°F to -25°F (0°C to -31°C)	0078 00
Starting Auxiliary Power Unit in Extreme Cold Weather +32°F to -25°F (0°C to -31°C)	0079 00
Preparation of Hydraulic System for Operation in Extreme Cold Weather +32°F to -25°F (0°C to -31°C)	0080 00
Extreme Hot Weather Operation	0081 00
Unusual Terrain Operation	0082 00
Fording	0083 00
Nuclear, Biological and Chemical (NBC) Decontamination	0084 00

CHAPTER 3 - TROUBLESHOOTING

Troubleshooting Introduction and Overview	0085 00
Quick Guide to Troubleshooting (Troubleshooting Index)	0086 00
Auxiliary Power Unit Troubleshooting	0087 00
Bilge Pump Troubleshooting (When Installed)	0088 00
Brakes Troubleshooting	0089 00
Engine Troubleshooting	0090 00
Exhaust Smoke Generating System Troubleshooting	0091 00
Gas Particulate Filter Unit Troubleshooting	0092 00
Generator System Troubleshooting	0093 00
Hydraulics System Troubleshooting	0094 00
Lights Troubleshooting	0095 00
Monitoring System Troubleshooting	0096 00

TABLE OF CONTENTS - CONTINUED

WP Sequence No.

CHAPTER 3 - TROUBLESHOOTING - CONTINUED

Personnel Heater Unit Troubleshooting	0097 00
Personnel Heater Unit Troubleshooting (Global A20)	0098 00
Power Takeoff Electrical System Troubleshooting	0099 00
Smoke Grenade Launcher System Troubleshooting	0100 00
Tracks and Suspension Troubleshooting	0101 00
Ventilating Blower Troubleshooting	0102 00
Warning System Troubleshooting	0103 00
Winch Electrical System Troubleshooting	0104 00

CHAPTER 4 - OPERATOR MAINTENANCE INSTRUCTIONS

Preventive Maintenance Checks and Services Including Lubrication Instructions	0105 00
Armor Skirt Panel Maintenance	0106 00
Opening, Removal, Installation and Closing of Armor Skirt Panels with Quick-Release Pin	0107 00
Track Tension Adjustment (Old Configuration)	0108 00
Track Tension Adjustment (New Configuration)	0109 00
Release Track Tension (Old Configuration)	0110 00
Release Track Tension (New Configuration)	0111 00
Track Adjusting Link Grease Fitting Replacement	0112 00
Track Shoe Replacement	0113 00
Track Removal	0114 00
Track Installation	0115 00
Air Cleaner Maintenance	0116 00
Auxiliary Power Unit Air Cleaner Maintenance	0117 00
Instrument, Dome and Blackout Marker Lights Maintenance	0118 00
Vision Devices Maintenance	0119 00
Turbo Dust Detector Maintenance	0120 00
Refueling	0121 00
Bleeding Trapped Air From Brake Lines	0122 00

MAINTENANCE UNDER UNUSUAL CONDITIONS

Extreme Cold Weather Maintenance	0123 00
Extreme Hot Weather Maintenance	0124 00
Maintenance After Fording	0125 00
Maintenance After Operation On Unusual Terrain	0126 00

MAINTENANCE OF AUXILIARY EQUIPMENT

Passive Night Viewer AN/VVS-2(V)1A	TM 11-5855-249-10
Driver's Viewer Enhancer	TM 11-5855-311-12&P-1
Caliber .50 Machine Gun and Mount Maintenance	0127 00
Welding Equipment Maintenance	0128 00
Gas-Particulate Filter Unit Maintenance	0129 00
Communications System Maintenance	0130 00
M239 Smoke Grenade System	0131 00

TABLE OF CONTENTS - CONTINUED

WP Sequence No.

CHAPTER 5 - SUPPORTING INFORMATION

References	0132 00
Components of End Item (COEI) and Basic Issue Items (BII) Lists	0133 00
Additional Authorization List (AAL)	0134 00
Expendable and Durable Items List	0135 00
Stowage and Sign Guide	0136 00
ALPHABETICAL INDEX	INDEX-1

HOW TO USE THIS MANUAL

This manual was designed to provide you with the information you will need to operate and maintain the M88A2 recovery vehicle.

The information contained in this manual is presented in chapters and work packages. Each chapter is divided into work packages to cover the subject or operating procedures for the vehicle systems or components. Where references are made to tables, figures, and work packages, refer to those portions of the text.

To find information relating to a specific component or system:

- Determine the specific name or function of the component/system.
- Find the name or function in the Index Listing, located in the back of this manual.
- Refer to appropriate work package(s) called out in Index Listing.

To find information pertaining to a broader range of information (such as vehicle troubleshooting, preventive maintenance and vehicle descriptions):

- Identify the desired topic.
- Find the general topic in the Table of Contents, located in the front of this manual.
- Refer to appropriate work package(s) called out in the Table of Contents.

IMPORTANT

You must read and understand this manual BEFORE operating the M88A2 recovery vehicle.

MAINTENANCE

Throughout this manual you will frequently see “notify unit maintenance”. When you are instructed to notify unit maintenance, do exactly that; they have the tools and training to efficiently and correctly perform the next level of maintenance.

Maintenance procedures are to be performed in the sequence shown in the text and illustrations. Step 1 must be performed before step 2 and so on.

Equipment illustrations use numbers to identify parts of the system/components.

Throughout this manual the words WARNING, CAUTION, and NOTE will appear. There is a reason for every one of them.

WARNING

A warning is used to alert the user to hazardous operating and maintenance procedures, practices, conditions, statements, etc. that may result in injury to or DEATH of personnel if not strictly observed.

CAUTION

A caution is used to alert the user of hazardous operating and maintenance procedures, practices, conditions, statements, etc. that may result in damage to or destruction of equipment or of mission effectiveness if not observed.

NOTE

A note is used to inform the user of essential information which is of special interest or importance or will aid the user in performing a job.

END OF TASK

GENERAL INFORMATION**0001 00**

THIS WORK PACKAGE COVERS:General Information

SCOPE

Type of manual: Operator's Manual

Equipment Name and Model Number: Recovery Vehicle, Heavy, Full-Track, M88A2.

Purpose of Equipment: To provide for recovery (hoist/winch/tow) of vehicles weighing up to 70 tons (63.49 metric tons).

MAINTENANCE FORMS AND PROCEDURES

Department of the Army forms and procedures used for equipment maintenance will be those prescribed by DA Pam 738-750, The Army Maintenance Management Systems (TAMMS) as contained in the Maintenance Management Update.

REPORTING EQUIPMENT IMPROVEMENT RECOMMENDATION (EIR)

If your vehicle needs improvement, let us know. Send us an EIR. You, the user, are the only one who can tell us what you don't like about your equipment. Let us know why you don't like the design or performance. Put it on a Standard Form 368 (Product Quality Deficiency Report). Mail it to Commander, U.S. Army Tank-automotive and Armament Command, ATTN: AMSTA-TR-QL, Warren, MI 48397-5000. We will send you a reply.

HAND RECEIPT (HR) MANUALS

This manual has a companion document with a TM number followed by "HR" (which stands for Hand Receipt). TM 9-2350-292-10-HR consists of preprinted hand receipts that list end item related equipment (i.e., COEI, BII and AAL) that must be accounted for. As an aid to property accountability, additional HR manuals may be requisitioned through normal publication channels.

CORROSION PREVENTION AND CONTROL (CPC)

Refer to page WP 0101 00 for detailed CPC information and reporting instructions.

DESTRUCTION OF ARMY MATERIEL TO PREVENT ENEMY USE

Destruction of the vehicle, armament, and equipment when subject to capture or abandonment in a combat zone will be undertaken only when the unit commander decides such action is necessary in accordance with TM 750-244-6, Procedure for Destruction of Tank-Automotive Equipment to Prevent Enemy Use, orders of, or policy established by, the Army commander.

WARRANTY INFORMATION

Refer to Warranty Technical Bulletin, TB 9-2350-292-15.

PREPARATION FOR STORAGE OR SHIPMENT

Requirements for storage or shipment, including packaging and administrative storage, of the M88A2 Hercules vehicle can be found in ATP-D-2229.

GENERAL INFORMATION - CONTINUED**0001 00****NOMENCLATURE CROSS-REFERENCE LIST**OFFICIAL PROVISIONINGNOMENCLATURECOMMON NAME

Powerpack gauge	Dipstick, bayonet gauge, gauge rod
Seat cushion	Backrest
Seat, individual	Crew seat
Socket head screw key	Hex key
Wire rope	Cable
Crowbar	Tanker's bar
Chain, lifting, Heavy Duty	V-chain/combat chain

LIST OF ABBREVIATIONS

AAL	Additional Authorized List
BII	Basic Issue Item
°C	Degree Centigrade
CARC	Chemical Agent Resistant Coating
CCW	Counterclockwise
CM	Centimeter
COEI	Component Of End Item
CPC	Corrosion Prevention and Control
CTA	Common Table of Allowances
CW	Clockwise
EIR	Equipment Improvement Recommendation
EOD	Explosive Ordnance Disposal
°F	Degree Fahrenheit
FES	Fire Extinguisher System
FOV	Family of Vehicles
FPM	Feet Per Minute
HR	Hand Receipt
KG	Kilogram
KPA	Kilopascal
KMPH	Kilometer Per Hour
L	Liter
M	Meter
MAX	Maximum
MHZ	Megahertz
MIN	Minimum
MPH	Miles Per Hour
NBC	Nuclear, Biological, Chemical
PMCS	Preventive Maintenance Checks and Services

GENERAL INFORMATION - CONTINUED

0001 00**LIST OF ABBREVIATIONS - CONTINUED**

PRV	Pressure Relief Valve
PSI	Pounds Per Square Inch
RF	Radio Frequency
RFI	Radio Frequency Interference
RPM	Revolutions Per Minute
SE	Support Equipment
SOI	Signal Operating Instructions
SOP	Standard Operating Procedures
STE	Special Test Equipment
STE/ICE-R	Simplified Test Equipment for Internal Combustion Engines Reprogrammable
VIS	Vehicle Intercommunication System (AN/VIC-3(V))
WP	Work Package

COPYRIGHT CREDIT LINE**COPYRIGHT © 1998 BY UNITED DEFENSE, L.P. ALL RIGHTS RESERVED UNDER THE COPYRIGHT LAWS.****THIS MATERIAL MAY BE REPRODUCED FOR U.S. GOVERNMENT PURPOSES ONLY, PURSUANT TO THE COPYRIGHT LICENSE UNDER THE CLAUSE AT (DFARS 52.227-7013) 1994.****END OF TASK**

CHAPTER 1

DESCRIPTION AND THEORY OF OPERATION

EQUIPMENT CHARACTERISTICS, CAPABILITIES AND FEATURES.

0002 00**THIS WORK PACKAGE COVERS:**Characteristics, Capabilities and Features

CHARACTERISTICS

The M88A2 Heavy Recovery Vehicle is an armored, full-tracked, low silhouette vehicle. It is used for hoisting, winching, and towing operations for all vehicles up to 70 tons (63.49 metric tons). It is equipped to assist in repairing disabled vehicles under field conditions. The vehicle carries a crew of three: Commander, Operator, and Mechanic/Rigger. Refer to FM 9-43-2, Vehicle Recovery Operation for recovery methods using the vehicle equipment.

CAPABILITIES AND FEATURES

- Maximum speed 25 mph (48.3 kmph) (without towed load)
- Maximum range without towed load, in third gear lockup is 314 mi (505.2 km)
- 1050 hp, 12-cylinder, 4-cycle, air-cooled, diesel main engine
- Combined transmission, differential, steering, and braking unit
- Hydraulic power-assisted braking
- Main winch maximum pull (straight line) 140,000 lbs (63,560 kg)
- Hoist winch maximum lift (four part line) 70,000 lbs (31,780 kg)
- Auxiliary winch maximum pull (straight line) 6,000 lbs (2,724 kg)
- Hull and cab armor protect vehicle from 30 mm direct fire
- 10.8 hp, 2-cylinder, 4-cycle, air-cooled, diesel auxiliary power unit (ONAN engine)
- 17.5 hp, 2-cylinder, 4-cycle, air-cooled, diesel auxiliary power unit (HATZ engine)
- Gas-particulate filter unit
- M239 smoke grenade system
- Exhaust smoke generating system
- Deep water fording kit
- .50 caliber machine gun, M2
- Two 5.56 mm caliber rifles, M16

END OF TASK

LOCATION AND DESCRIPTION OF MAJOR COMPONENTS.

0003 00

1	Auxiliary Winch	Used to deploy the main winch cable.
2	Night vision viewer protective cover	Protects the AN/VVS-2(V) night vision viewer hood when installed in the driver's hatch during operation.
3	Emergency flasher light	Flashing amber light for emergency situations.
4	Turn signal lamps	Used when driving to indicate intended turns.
5	Level winder	Used to spool the main winch cable properly onto the main winch drum.
6	Towing lugs	Used to tow the M88A2 if disabled.
7	Winch lug	Used to connect main winch cable back to M88A2 during two-part line recovery operations.
8	Spade	Used to prepare the recovery site and to stabilize the M88A2 when hoisting or winching heavy loads.
9	Headlights	Provide light for driving at night and under blackout conditions.
10	Horn assembly	Used as a warning device.
11	M239 smoke grenade launchers	Used to fire smoke grenades to provide concealment.
12	Vision blocks	Allows the crew to see outside the vehicle while operating with the hatches closed.
13	Front lifting eyes	Used to hoist the M88A2 for transport.
14	M17 periscopes	Allows the crew to see outside the vehicle while operating with the hatches closed.

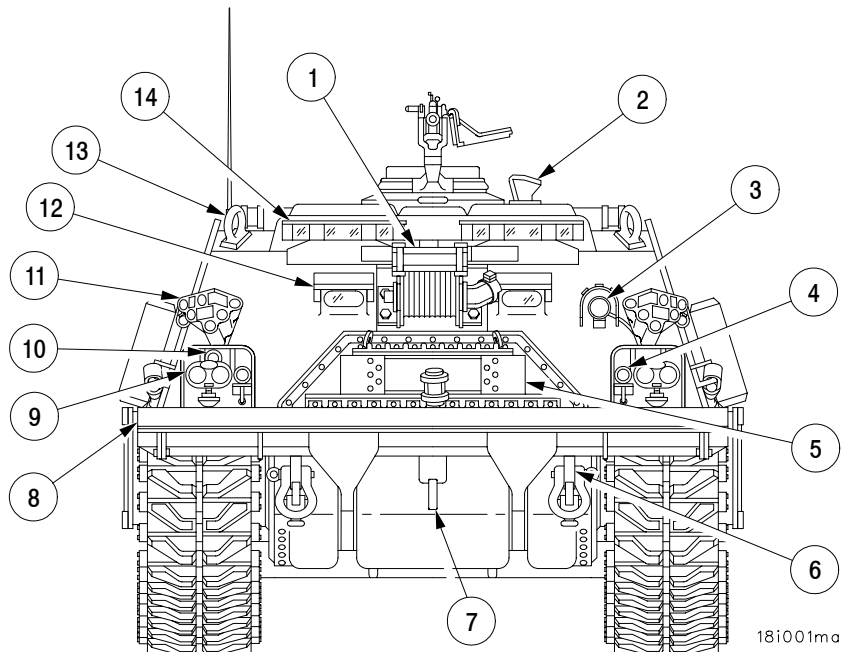

LOCATION AND DESCRIPTION OF MAJOR COMPONENTS - CONTINUED

0003 00

- | | | |
|----|--|--|
| 15 | M2 .50 caliber machine gun | Provides for air and troop defense. |
| 16 | Antenna | Used with the radio sets to receive and transmit radio signals. |
| 17 | Decontamination Kit | Used to decontaminate exterior of vehicle. |
| 18 | Commander's cupola | Allows the commander access to the machine gun and the top of the vehicle. |
| 19 | Boom | Used with the hoist winch to lift loads. (Some booms are equipped with steps and rungs.) |
| 20 | Stayline arms | Used to move boom rearward during boom operation. |
| 21 | Travel lock | Secures the boom to the vehicle when not in use. |
| 22 | Boom pulleys | The hoist winch cable rides in these when the boom is rigged. |
| 23 | Stayline cables | Provide support and control for the boom when it is raised. |
| 24 | Sprocket, roadwheel and support roller | Spare parts for in-the-field replacement. |

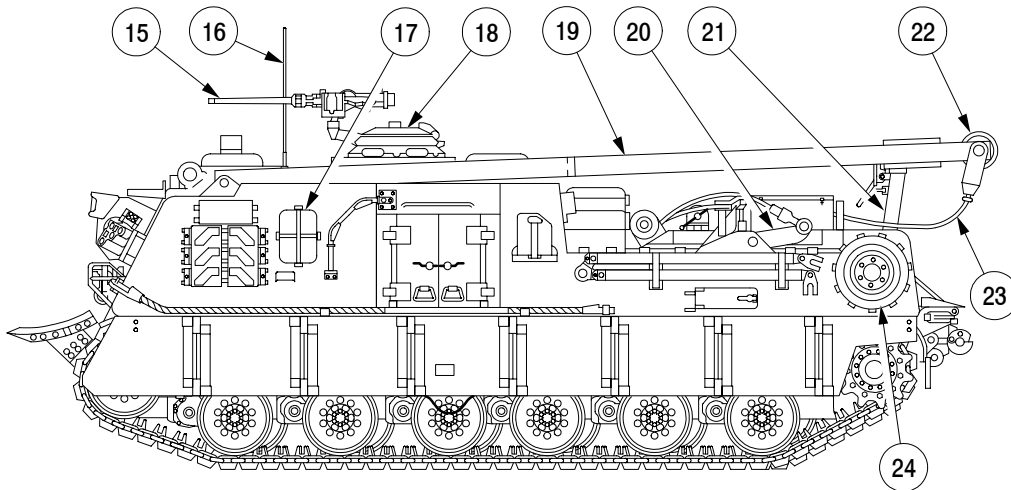

181003m

LOCATION AND DESCRIPTION OF MAJOR COMPONENTS - CONTINUED

0003 00

25	Smoke grenade storage box	Provides storage for smoke grenades used with the M239 smoke grenade launchers.
26	Auxiliary boom	Used with the chain hoist to lift heavy objects on or near the vehicle.
27	Left side storage compartment door	Allows access to the left side storage compartment.
28	Spare tow bar	Used to tow disabled vehicles.
29	Oil can	Used to carry extra oil for vehicle maintenance.
30	Left side personnel doors	Allow access to the crew compartment.
31	Armor skirt panels	Provides protection for the tracks and suspension from small arms fire.
32	Remote fire extinguisher pull handles	Provides remote discharge of the fire extinguisher system.
33	Spare track shoes	Used to replace damaged track shoes.
34	Towing cables	Used to tow disabled vehicles over rough terrain in an emergency and uprighting overturned vehicles.

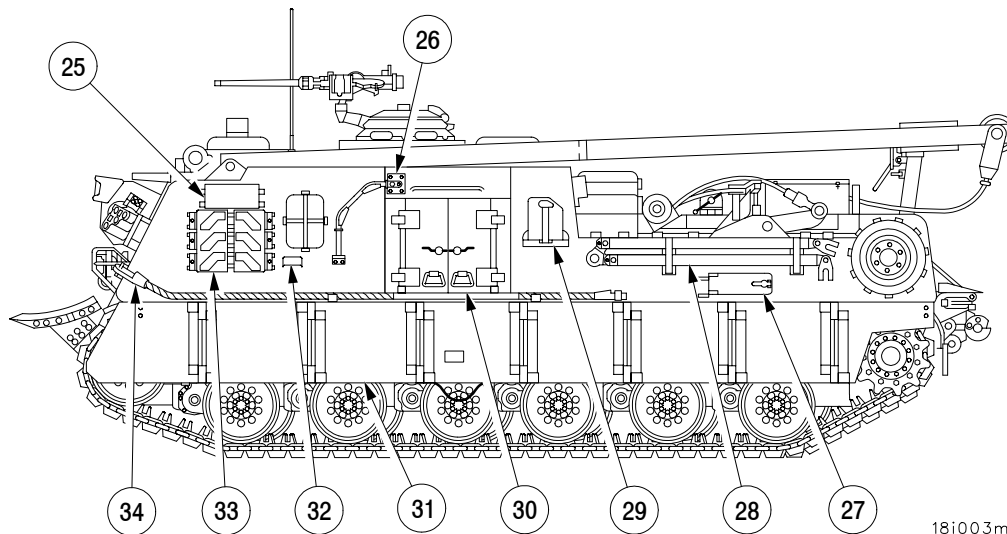

18i003ma

LOCATION AND DESCRIPTION OF MAJOR COMPONENTS - CONTINUED

0003 00

35	Vision blocks	Allows the crew to see outside the vehicle with the hatches closed.
36	Auxiliary boom receptacles	Holds the base of the auxiliary boom when lifting. Eight receptacles are located on the vehicle.
37	Rear service lights	Provides light to perform recovery operations during low light or night operations.
38	Exhaust grille	Deflects exhaust gases backward away from the vehicle.
39	Exhaust deflector	Deflects exhaust gases upward away from the vehicle.
40	Towing pintle	Used to tow disabled vehicles with the tow bar.
41	Combat tow chain	Used to tow/recover disabled vehicles.
42	Towing lugs	Towing shackles connect to these for towing disabled vehicles.
43	Tow bar	Used to tow disabled vehicles.
44	Rear fender skirt	Deflects materials picked up by the tracks back down to the ground instead of throwing it into the air.
45	Taillight assembly	Contains the stoplights, rear turn signals, blackout markers, and blackout brake-lights.

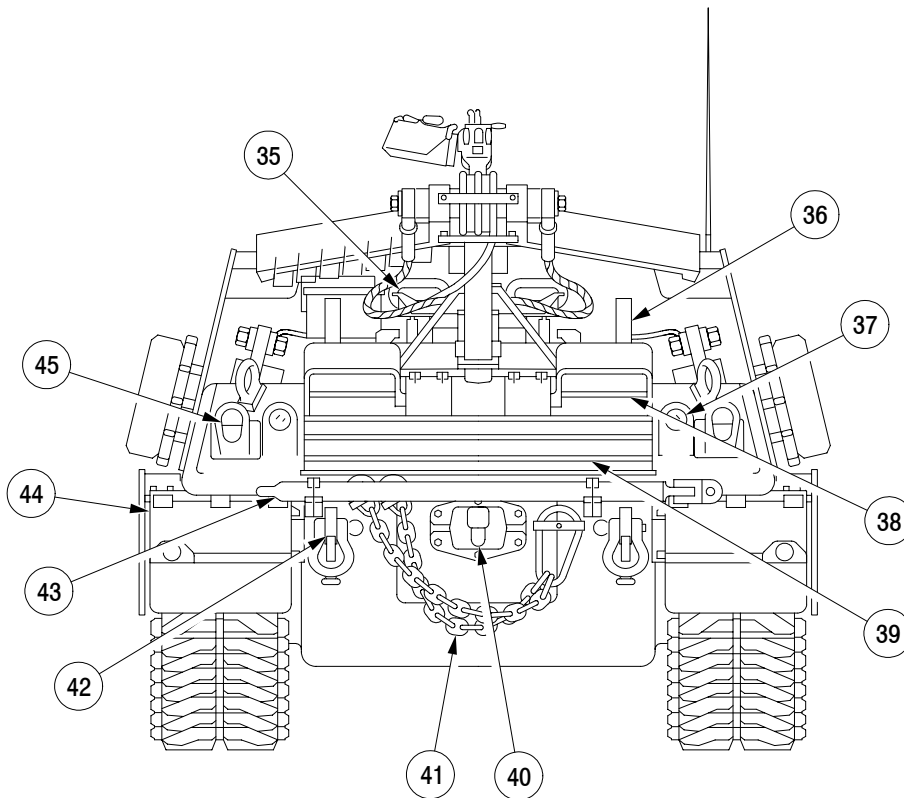

18i002m

LOCATION AND DESCRIPTION OF MAJOR COMPONENTS - CONTINUED

0003 00

- | | | |
|----|---|---|
| 46 | Pioneer tools | Consists of an axe, shovel, and mattock for recovery operations. (Some vehicles may be equipped with an enclosed Pioneer Tool Kit Assembly) |
| 47 | Right side storage compartment door | Allows access to the right side storage compartment, refuel/defuel controls, and impact wrench controls. |
| 48 | Auxiliary power unit (APU) compartment door | Allows access to the APU compartment. |
| 49 | Right side personnel doors | Allows access to the crew compartment. |
| 50 | 140-ton snatch block | Used with the main winch cable during two-part line recovery operations. |
| 51 | Compensating idler wheels | Used to maintain track tension. |
| 52 | Adjusting link assembly | Used to adjust track tension. |

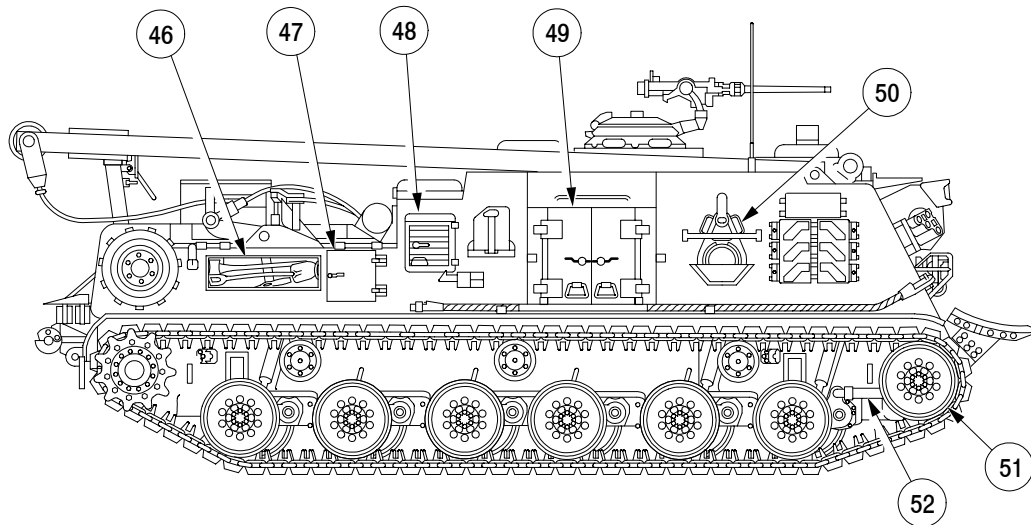

SIDE ARMOR SKIRT PANELS REMOVED FOR CLARITY

18i004m

LOCATION AND DESCRIPTION OF MAJOR COMPONENTS - CONTINUED

0003 00

53	Shock absorbers	Three shock absorbers per side absorb road shock while vehicle is moving.
54	Stop blocks	Steel plates welded to the hull above roadwheels 2 through 5 that limit windup of the torsion bars.
55	Roadwheel arm	Connect the roadwheels to the hull and torsion bars.
56	Roadwheel	Six sets of roadwheels on each side provide support and guide the track.
57	Track	Provides mobility for the vehicle.
58	Support rollers	Three sets of support rollers on each side provide support and guide the upper part of the track.
59	Bumper stops	Two bumper stops on each side provide secondary dampening action to stabilize the vehicle while traveling.
60	Tiedown eyes	Four eyes, one at each corner, used to secure the vehicle during transport.
61	Drive sprocket	Transfers the power from the output reduction drives to the track to move the vehicle.

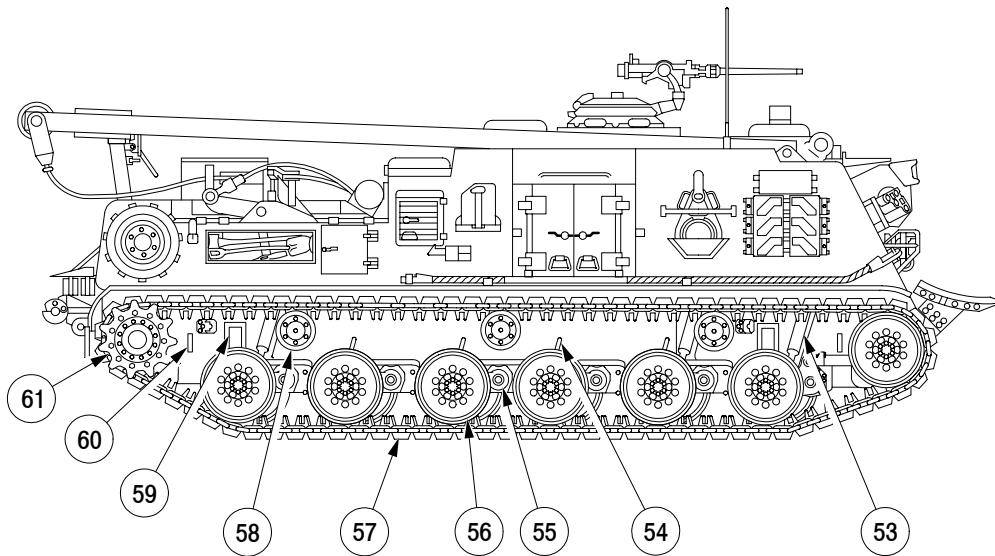

SIDE ARMOR SKIRT PANELS REMOVED FOR CLARITY

18i004ma

LOCATION AND DESCRIPTION OF MAJOR COMPONENTS - CONTINUED

0003 00

62	Hoist winch cable hatch	Allows access to the hoist winch cable for hoisting operations.
63	Mechanic's hatch	Allows the mechanic to enter/exit the crew compartment from the top of the vehicle.
64	Personnel hatch	Allows personnel to enter/exit the crew compartment from the top of the vehicle. (Some vehicles are not equipped with personnel hatch.)
65	Spotlight	Provides a steerable light for night operations.
66	Front engine deck grilles	Allows cooling air to enter the engine compartment.
67	Oxygen cylinder	Used in conjunction with the acetylene tank for welding/cutting operations.
68	Engine deck side grille	Allows cooling air to enter the engine compartment.
69	Sledge hammer	Used for track repairs.
70	Engine deck door	Allows access to the engine oil fill and engine oil check doors.

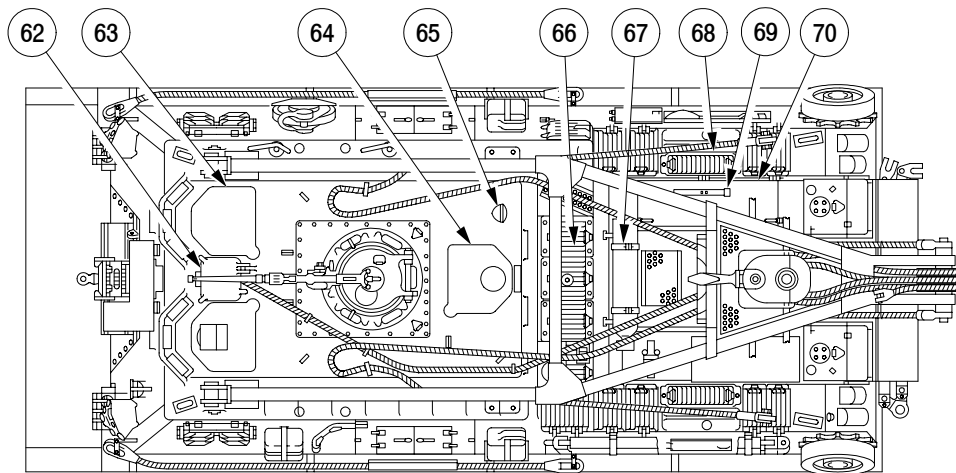

18i006m

LOCATION AND DESCRIPTION OF MAJOR COMPONENTS - CONTINUED

0003 00

- | | | |
|----|---|--|
| 71 | Engine deck grille doors | Allow cooling air to enter the engine compartment and allows access to the batteries. |
| 72 | Rear lifting eyes | Used to hoist the M88A2 for transport. |
| 73 | Retaining straps | Used to secure the 35-ton hook block in the boom tray. |
| 74 | 35-ton hook block | Used to hoist loads in conjunction with the boom. |
| 75 | Engine deck storage box | Used to store BII and COEI items. |
| 76 | Auxiliary power (NATO Slave) receptacle | Used to connect two vehicles together to charge the batteries or jump start the main engine. |
| 77 | Boom tray | Holds the 35-ton hook block when the boom is in the travel lock position. |
| 78 | Vise | Used to hold items while performing maintenance. |
| 79 | Engine deck storage tray | Used to store the canvas cover, ropes, etc. |
| 80 | Fuel filler cap protective cover | Allows access to the fuel cap for refueling the vehicle. |
| 81 | Driver's hatch | Allows the driver to enter/exit the crew compartment from the top of the vehicle. |

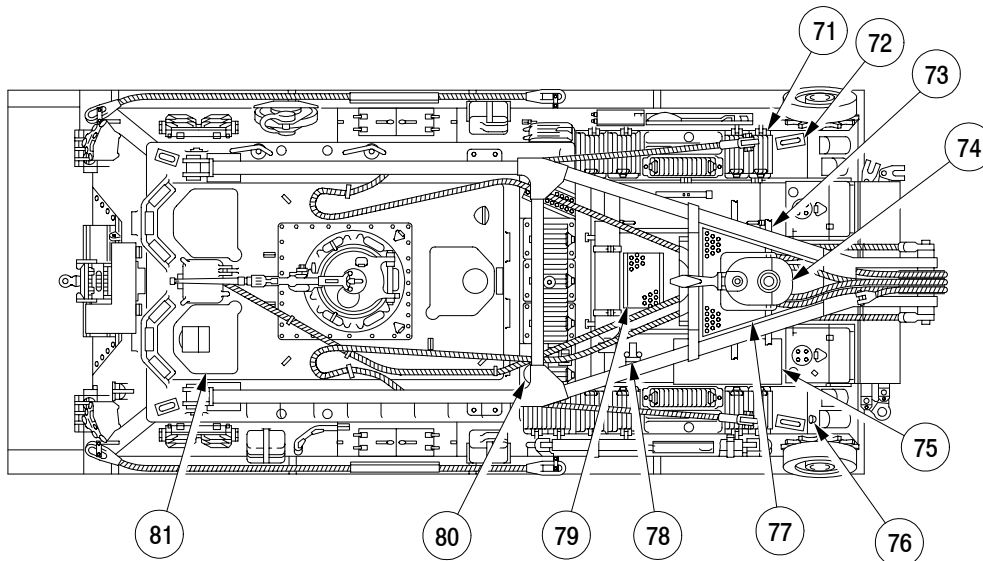

18i006ma

LOCATION AND DESCRIPTION OF MAJOR COMPONENTS - CONTINUED

0003 00

82	Hydraulic control valve manifold	Consists of seven bidirectional control valves that allow the operator to operate the spade, boom, main winch, hoist winch, auxiliary winch, and hydraulic system.
83	Hoist winch cable chute	Provides a channel through the crew compartment for the hoist winch cable.
84	Communications system	Consists of intercommunication equipment for internal communications and radio sets for external communications.
85	Commander's seat	Provides a place for the commander to sit while the vehicle is moving.
86	Air cleaner	Two air cleaners, one on each side of the crew compartment, filter the air before it is supplied to the main engine.
87	Personnel heater	Provides heat for the crew during cold weather. Vehicle may be equipped with a Stewart-Warner or a Global A20 heater. The Global A20 heater can be identified by a diagnostic display window located on the heater top cover.
88	Auxiliary hydraulic pump	Provides backup hydraulic system in the event the main hydraulic system is non-operational. Also provides hydraulic power to operate the refuel/defuel pump and impact wrench.
89	Auxiliary power unit (APU)	Provides power to drive the auxiliary hydraulic pump and the auxiliary generator.

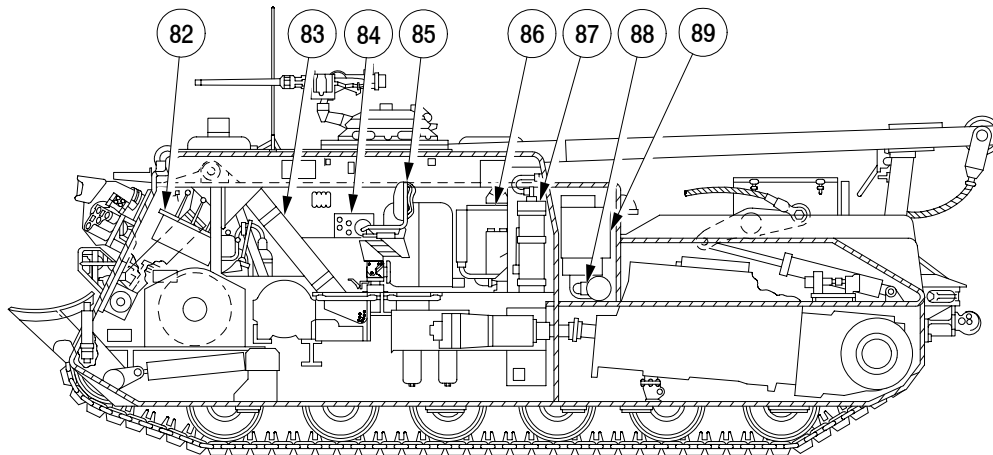

18i005m

LOCATION AND DESCRIPTION OF MAJOR COMPONENTS - CONTINUED

0003 00

90	Motor/generator	Used to start the APU and to charge the vehicle batteries.
91	Stayline cylinders	Control live boom movement during hoisting operations.
92	Refuel/defuel pump	Hydraulically driven pump used to refuel/defuel the vehicle.
93	Output reduction drives	Transfer power from the transmission to the drive sprockets. Also provide braking to stop the vehicle.
94	Transmission	Provides three forward speeds, reverse, and neutral to transfer power from the engine to the output reduction drives.
95	Main engine	Provides power to move the vehicle and drive the main hydraulic system.
96	Power takeoff (PTO)	Transfers power from the main engine through the electromagnetic clutch to the hydraulic pumps.
97	Hydraulic reservoir	Supplies hydraulic fluid to the hydraulic systems.
98	Electromagnetic clutch	Allows the main engine power to be engaged/disengaged from the hydraulic pumps.
99	Hydraulic pumps	Provide hydraulic pressure to the hydraulic system.
100	Filter manifold	Contains two filters which filter the hydraulic fluid.
101	Subfloor stowage baskets	Provide internal stowage for BII and COEI equipment.

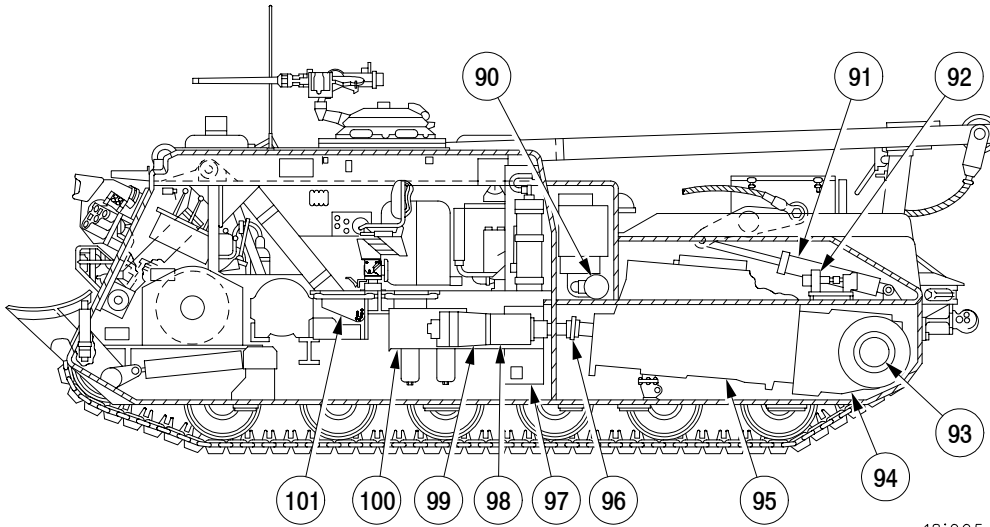

18i005ma

LOCATION AND DESCRIPTION OF MAJOR COMPONENTS - CONTINUED

0003 00

- | | | |
|-----|-----------------------|--|
| 102 | Hoist winch | Used to lift loads in conjunction with the boom. |
| 103 | Spade cylinders | Used to raise/lower the spade. |
| 104 | Main winch | Used to winch loads during recovery operations. |
| 105 | Spade lock | Hydraulic cylinder which locks the spade in the full-up position when not in use. |
| 106 | Level winder cylinder | Moves the level winder left/right during main winch operations to provide proper spooling of the main winch cable. |
| 107 | Boom cylinders | Used to raise and lower the boom. |

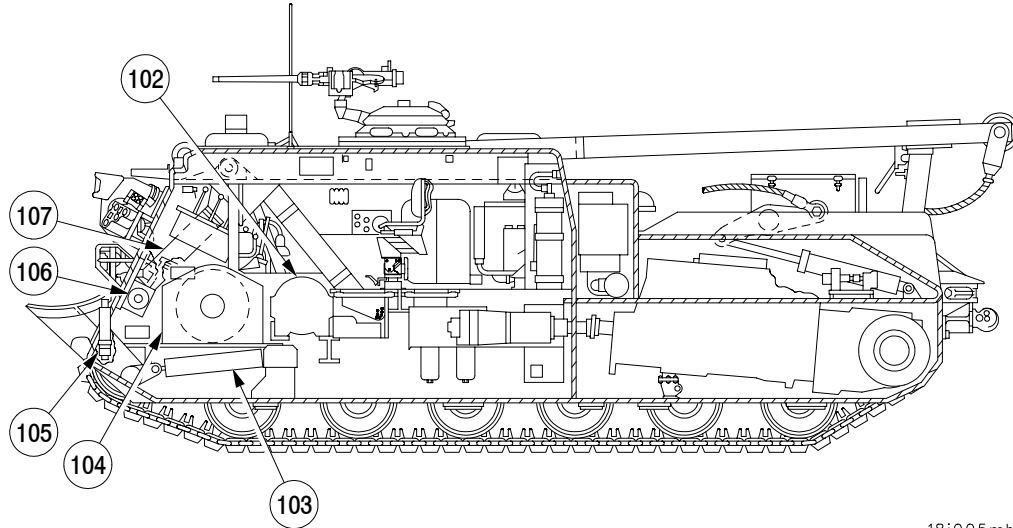

18i005mb

END OF TASK

EQUIPMENT DATA.

Weight:

Combat loaded 139,600 lb (63,699 kg)

Dimensions:

Length 28.33 ft (8.64 m)
 Width 12 ft (3.66 m)
 Height 9.75 ft (2.97 m)
 Ground pressure 13.39 psi (92.3 kPa)

Capacities (refill approximate):

Fuel tanks 413 gal. (1563 l)
 Main engine crankcase (refill) 18.5 gal. (70.02 l)
 Transmission (refill) 17 gal. (64.35 l)
 Main winch 9.5 gal. (36.0 l)
 Hoist winch 9 pt (4.23 l)
 Auxiliary winch 6 pt (2.82 l)
 Hydraulic system 80 gal. (302.8 l)
 Electromagnetic clutch 5.2 qts (4.94 l)

Electrical System:

Batteries six 12 V
 Battery power 24 V dc
 Generator power 28±0.7 V dc

Performance:

Speed (max) (without towed load) 25 mph (48.3 kmph)
 Cruising range (max) 314 mi (505.2 km)
 Grade ascending ability (max) 60 percent
 Grade descending ability (max) 60 percent
 Side slope grade (max) 30 percent
 Maximum vertical wall 42 in. (1.07 m)
 Maximum trench crossing width 8.5 ft (2.59 m)
 Minimum turning radius pivot in one vehicle length
 Draw bar pull 107,000 lb (48,578 kg)
 Boom capacity (spade down) 70,000 lb (31,780 kg)
 Boom lift height:
 8-ft reach 22.5 ft (6.9 m)
 4-ft reach 25.13 ft (7.66 m)

Hoisting capacity (four-part line):

Spade up 12,000 lb (5,448 kg)
 Spade up with lockout blocks installed .. 50,000 lb (22,700 kg)
 Spade down 70,000 lb (31,780 kg)

EQUIPMENT DATA - CONTINUED

0004 00

Main winch:	
Cable size	1.4 in. (.0356 m)
Cable length	320 ft (97.53 m)
Useable length	280 ft (85.34 m)
Cable speed	20 fpm (6.1 mpm)
Straight line pull	140,000 lb (63,560 kg)
Hoist winch:	
Cable size	3/4 in. (.019m)
Cable length	225 ft (68.58 m)
Useable length	41 ft (12.5 m)
Straight line pull	17,500 lb (7,945 kg)
Auxiliary winch:	
Cable size	3/8 in. (.00952 m)
Cable length	668 ft (203.60 m)
Useable length	654 ft (199.34 m)
Straight line pull	6,000 lb (2724 kg)

Auxiliary Equipment:

Fire extinguisher:	
Portable (2 included):	
Type	Carbon dioxide (CO ₂)
Volume	218 cu in. (3.57 l)
Weight empty	5 lb (2.27 kg)
Weight fully-charged	15.5 lb (7 kg)

Fixed (two banks of 4 cylinders):	
Type	Carbon dioxide (CO ₂)
Volume	505 cu in. (8.28 l)
Weight empty	10 lb (4.5 kg)
Weight fully-charged	45 lb (20.4 kg)

Communications equipment:	
Radio set and interphone, consisting of:	
Radio sets - AN/VRC-90A	
Suppressor - MX 7778A	
Intercommunication system - AN/VIC-1(V)	
(four controls) or AN/VIC-3(V)	
(four controls and loudspeaker)	

Smoke grenade equipment (M239) consisting of:	
Grenade bin	
Canvas covers	
Push button control unit	
Dischargers	
12 red phosphorous grenades	

Exhaust smoke generating system consisting of:	
Modification kit 12275753 (engine - NSN 2815-01-077-7856)	
Modification kit 1672388 (hull - NSN 2590-01-084-6051)	

Fording:	
Without fording kit	56 in. (1.422 m)
With fording kit	90 in. (2.286 m)

END OF TASK

POWERPACK

- **Engine (1)** - is an air-cooled, 12-cylinder, 90-degree, V-type, 4-cycle, turbo-supercharged diesel. The engine develops 1050 horsepower at 2400 rpm and delivers that power to the transmission (2).
- **Transmission and Output Reduction Drives** - the cross-drive transmission is a combined transmission center section (2) with steering unit and two output reduction drives (3). The transmission provides power to the drive sprockets at an output torque which varies automatically according to the drive-load conditions when not in lockup. There are three forward speeds, one reverse, and one neutral. Steering is possible in all drive ranges and neutral. Steering in neutral causes the vehicle to pivot in place, the tracks turning in opposite directions.

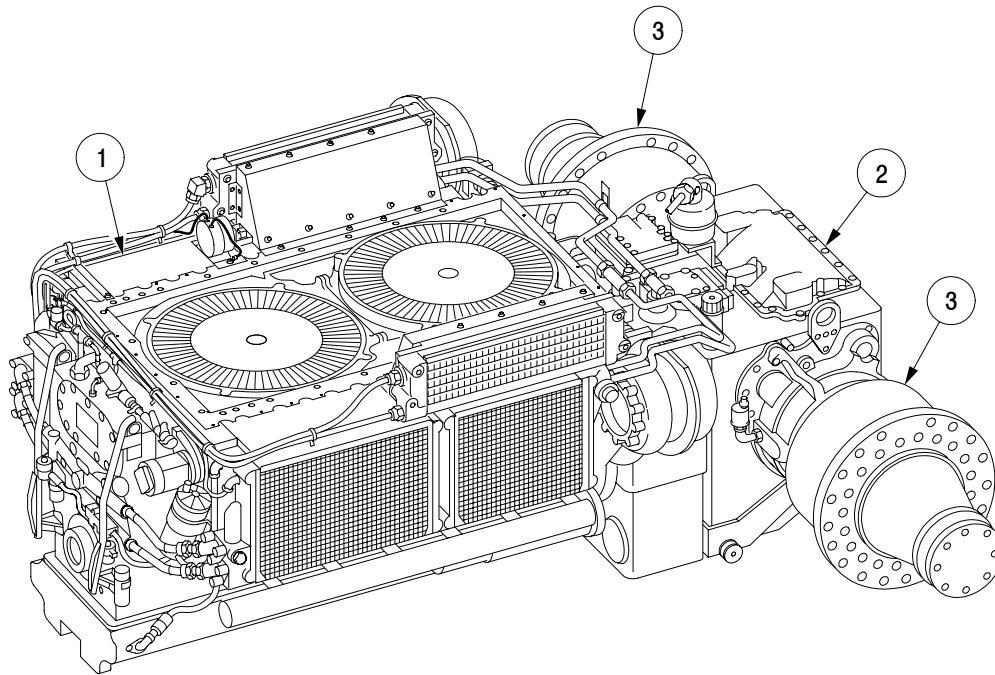

011002mc

THEORY OF OPERATION - CONTINUED

0005 00

COOLING SYSTEM

- **Air Intake Grilles** (1) - allows cooling air to enter the engine compartment.
- **Engine Oil Coolers** (2) - circulate engine oil. Air flows through the coolers to remove excess heat.
- **Exhaust Deflector Doors** (3) - provide an outlet for the exhaust system.
- **Transmission Oil Coolers** (4) - circulate transmission oil. Air flows through the coolers to remove excess heat.
- **Engine Driven Fans** (5) - circulate the cooling air through the engine compartment. They are driven by the engine through an oil-cooled clutch assembly that is designed to slip under deep water fording conditions where the resistance of the water exceeds the friction of the clutch.
- **Hydraulic Oil Coolers** (6) - circulate hydraulic oil. Air flows through the coolers to remove excess heat. Hydraulic oil coolers are mounted on top of transmission coolers.

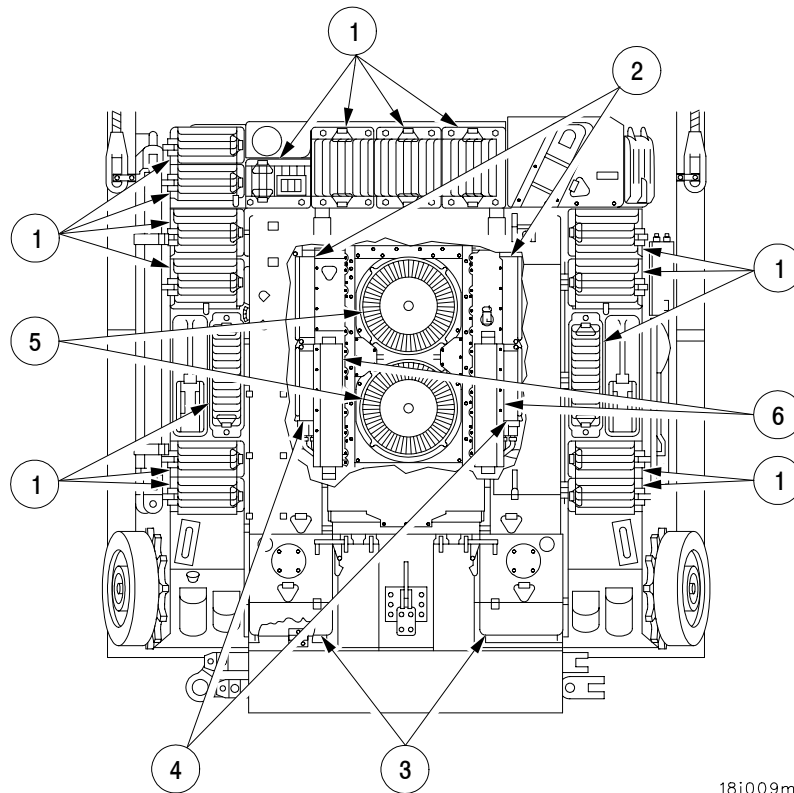

18i009m

THEORY OF OPERATION - CONTINUED

0005 00

AIR INTAKE SYSTEM

- **Damper Control** (1) - allows AIR SOURCE selection between OUTSIDE air or INSIDE (crew compartment) air.
- **Dry-type Air Filter** (2) - one on each side of the crew compartment. Filters dust and dirt from the air before it enters the turbochargers (3) and main engine.
- **Turbochargers** (3) - are exhaust gas driven and boost the air pressure entering the intake manifold (4) and main engine which increases the horsepower output.
- **Intake Manifold** (4) - distributes air to each cylinder in the main engine.

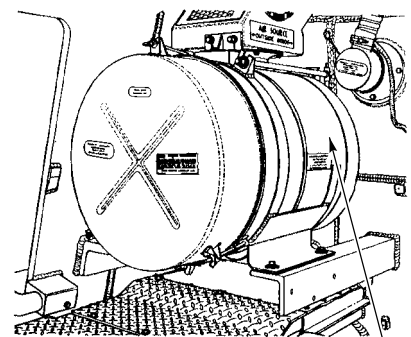
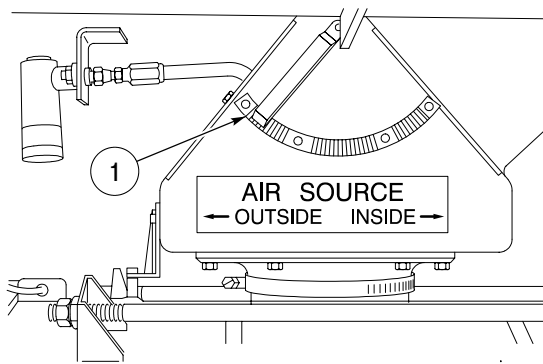

01i008m

2

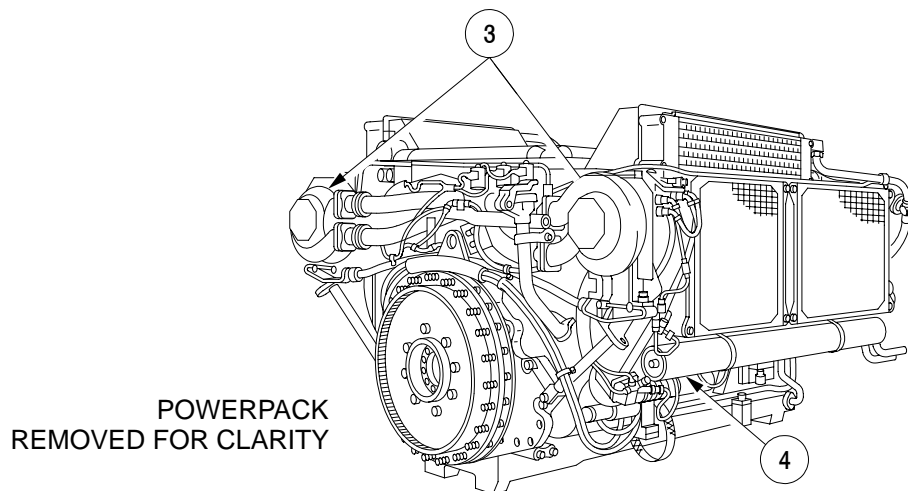

01i008mf

EXHAUST SYSTEM

- **Exhaust Manifold** (1) - collects exhaust gas from each cylinder and directs it to the turbochargers (2).
- **Turbochargers** (2) - driven by the hot exhaust gases from the cylinders. It is mechanically connected to the turbocharger in the air intake system to boost intake air pressures which increase horsepower.
- **Exhaust Pipe** (3) - directs exhaust gases out of the engine compartment.

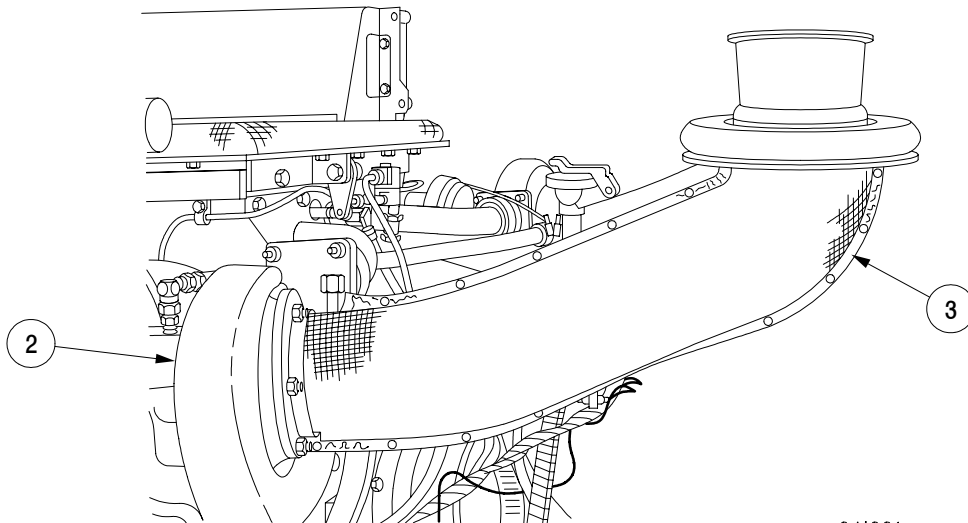
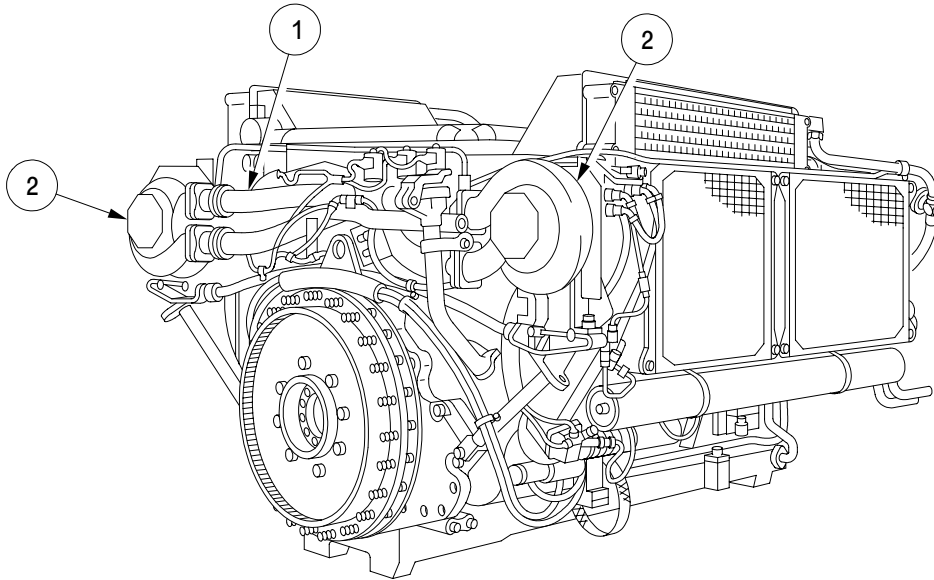

04i001m

TRACK AND SUSPENSION

- **Track Support Roller (1)** - supports the weight of the track (2) as it returns to the front of the vehicle when moving. There are three per side.
- **Tracks (2)** - consist of rubber track shoes, end connectors (with bolts and wedges) and center guides.
- **Track Drive Hub and Sprocket (3)** - receives power from the transmission output reduction drives and applies it to the tracks (2) to move the vehicle.
- **Bumper Assembly (4)** - provides secondary dampening action in conjunction with the torsion bars (10). Mounted on first and sixth roadwheels.
- **Shock Absorbers (5)** - mounted between the first, second and sixth roadwheel arms (6) and hull to dampen torsion bar (10) action.
- **Roadwheel Arm (6)** - connected to the torsion bar (10). The roadwheels (7) mount to the roadwheel arms.
- **Roadwheel (7)** - mounted to the roadwheel arm (6) and ride on top of the track (2) providing support and guiding the track (2). There are six per side.
- **“Stop” Blocks (8)** - welded to the hull over the second through fifth roadwheels to limit torsion bar wind up beyond allowable limits.
- **Torsion Bar Anchors (hidden) (9)** - secure the ends of the torsion bars (10). One anchor secures one torsion bar (10).
- **Torsion Bar (10)** - secured at the anchor (9) and connected to the roadwheel arm (6), the torsion bar acts as a spring for the roadwheel (7).
- **Adjusting Link Assembly (11)** - provides for track (2) tension adjustments.
- **Compensating Idler Wheel (12)** - provides the interface between the track (2) and the adjusting link assembly (11).

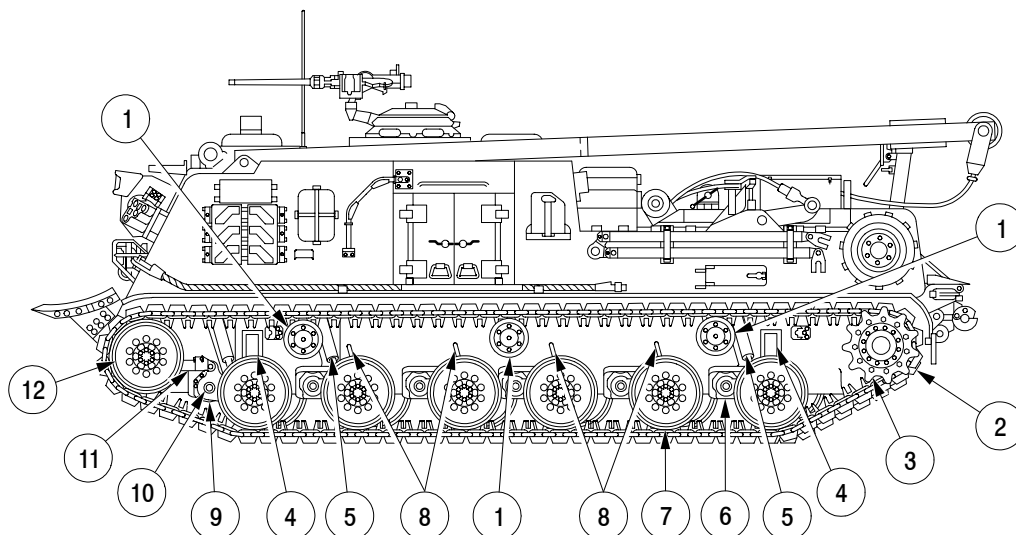

131001ma

SIDE ARMOR SKIRT PANELS REMOVED FOR CLARITY

THEORY OF OPERATION - CONTINUED

0005 00

FIXED FIRE EXTINGUISHER SYSTEM (FES)

- **Dual Pull Mechanism** (1) - connects the two sets of remote control pull handles (3 and 6) to the cylinder control valves (4) via cables.
- **Engine Shutoff Switch** (2) - closes the fuel shutoff solenoid valve in the fuel system when the interior remote control pull handle (3) shield is released. This action shuts down the main engine if it is running. Refer to WP 0006 00 for operation.
- **Interior Remote Control Pull Handles** (3) - discharge the FES when pulled.
- **Cylinder Control Valve** (4) - controls the discharging of the cylinder banks. The cylinder control valves are operated by the remote control pull handles or manually by moving the lever.
- **CO₂ Cylinder** (5) - eight 10-lb cylinders are located in two banks of four cylinders each on the left and right sides of the crew compartment. Each bank is connected to a cylinder control valve (4).
- **Exterior Remote Control Pull Handles** (6) - discharge the FES when pulled.

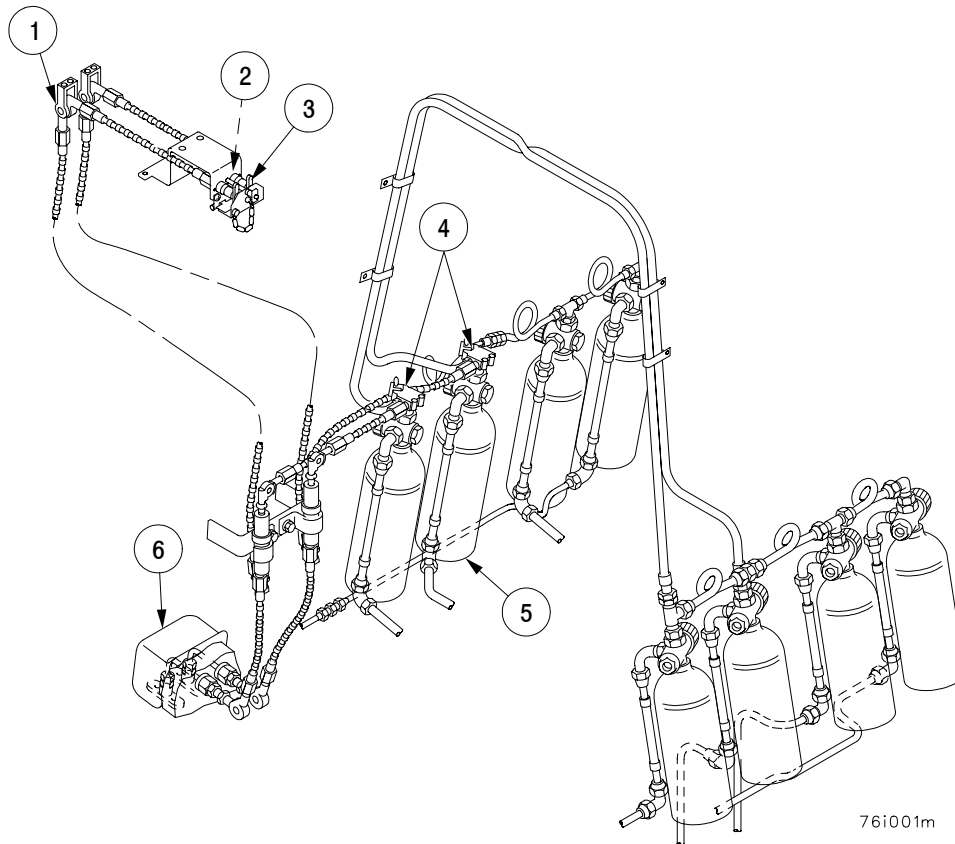

HYDRAULIC SYSTEMS

- **Operator's Control Valve Manifold (1)** - contains the directional control valves that allow the operator to control the hydraulic systems.
- **Power Takeoff (PTO) (2)** - mechanically connects the main engine to the electromagnetic clutch.
- **Electromagnetic Clutch (3)** - when engaged manually or by the PTO CLUTCH switch, directs power from the main engine via the PTO to the hydraulic pumps.
- **Hydraulic Pumps (4)** - provide hydraulic pressure to operate the hydraulic system.
- **Filter Valve Manifold (5)** - directs hydraulic fluid through two hydraulic filters.
- **Hoist Winch (6)** - capable of hauling a maximum load of 70,000 lbs (31,780 kg) with a four part line. Wound with 225 ft (68.58 m) of .75 in. (0.019 m) steel cable with a useable cable length of 41 ft (12.5 m). Use with hoisting boom.
- **Main Winch (7)** - used for heavy-duty recovery operations. Capable of winching a maximum load of 140,000 lbs (63,560 kg) with four wraps on the drum. Wound with 320 ft (97.53 m) of 1.4 in. (0.0356 m) steel cable with a useable cable length of 280 ft (85.34 m).
- **Level Winder (8)** - controls the cable placement on the main winch drum.
- **Auxiliary Winch (9)** - used to deploy the main winch cable during recovery operations. Wound with 670 ft (203.60 m) of .375 in. (0.00952 m) steel cable with a useable cable length of 654 ft (199.34 m).

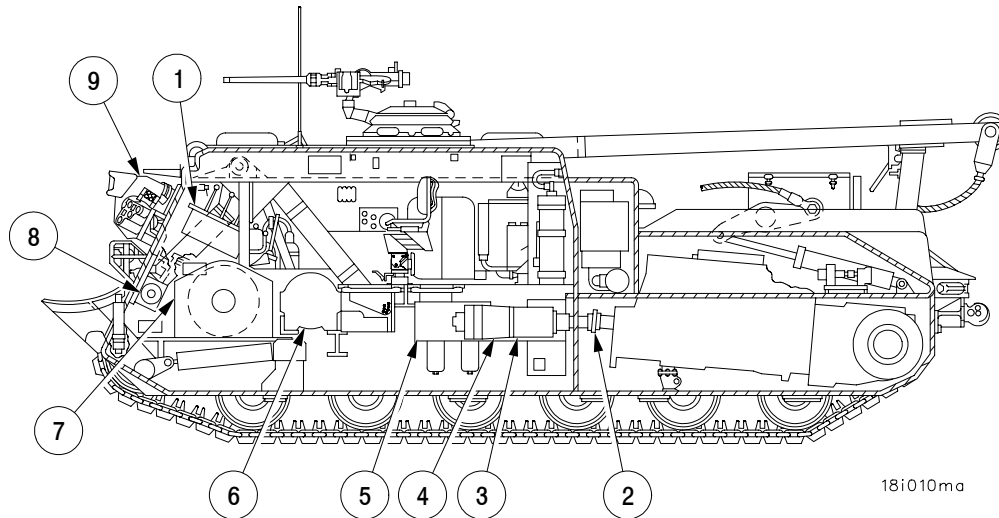

18i010ma

HYDRAULIC SYSTEMS - CONTINUED

- **Boom Cylinders** (10) - used to raise and lower the boom from the travel lock position to full forward position.
- **Stayline Cylinders** (11) - work in conjunction with the boom cylinders to move the boom backward in the 4 to 8 ft (1.2 to 2.4 m) live boom area during hoisting operations.
- **Hydraulic Reservoir** (12) - contains the hydraulic fluid used by the hydraulic system.
- **Spade Cylinders** (13) - used to raise and lower the spade during recovery operations.
- **Spade Lock Cylinder** (14) - used to secure the spade in the full-up position when not in use.

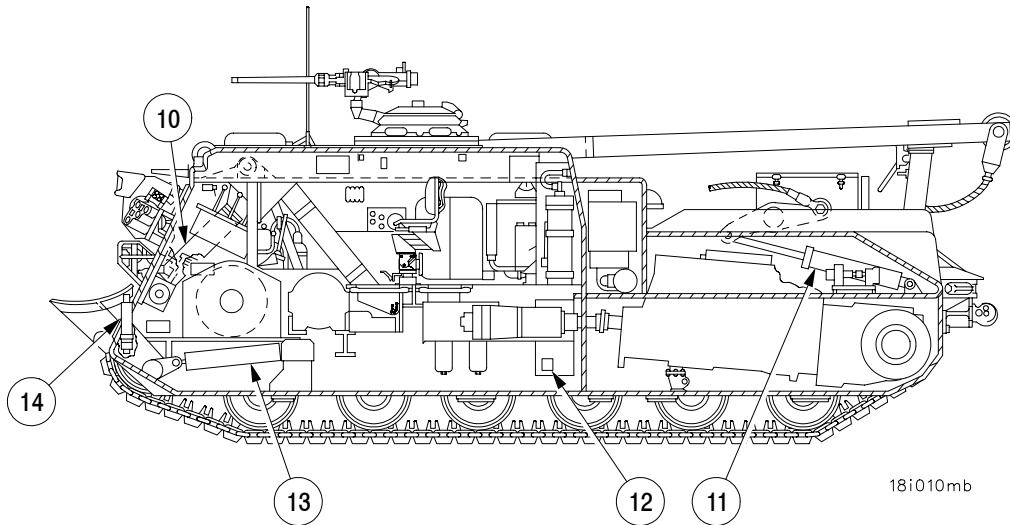

HYDRAULIC SYSTEMS - CONTINUED

- **FUEL PUMP CONTROL Valve** (15) - controls the direction of fuel flow during refuel / defuel operations.
- **FLOW REGULATOR** (16) - controls the rate of hydraulic oil flow through either the impact wrench or the refuel / defuel pump.
- **Hydraulic Assist Braking** (17) - pressure activated hydraulic assist brake system augments mechanical brake linkage.

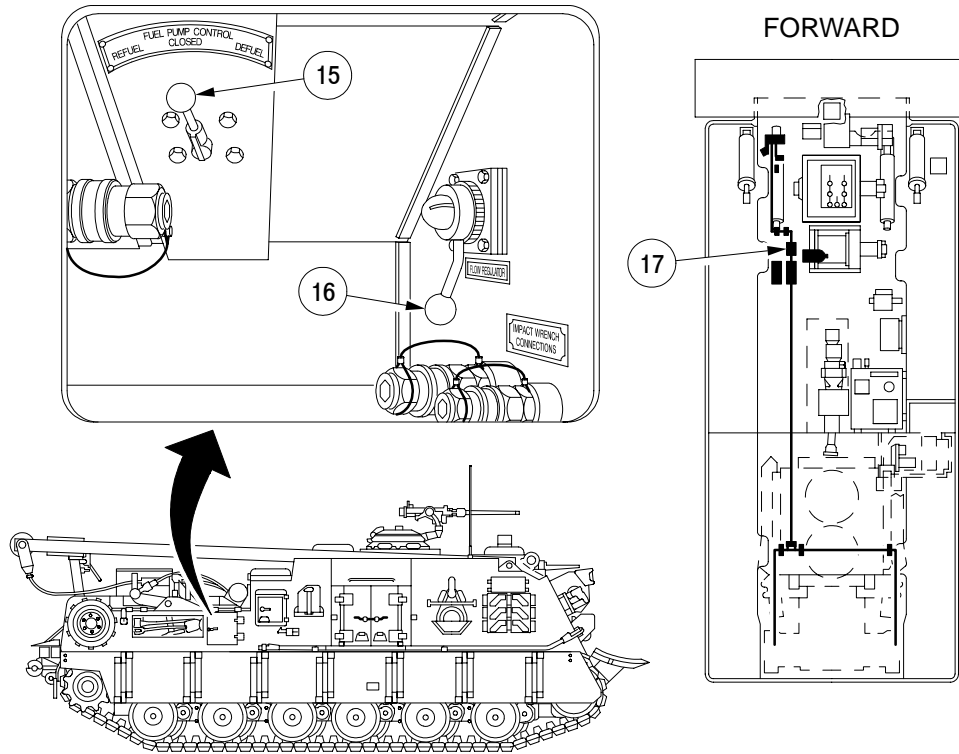

18i011m

AUXILIARY POWER UNIT

- **Voltage Regulator** (1) - voltage regulator receives 28 V dc from the starter/generator (3) and provides 28 ± 0.7 V dc to charge the vehicle batteries. Voltage regulator (1) is equipped with a resettable circuit breaker. If the circuit breaker opens due to an over voltage condition, the reset button (5) can be pushed to reset the circuit breaker.
- **Engine** (2) - burns fuel drawn from the right rear fuel tank. Engine drives starter/generator (3) and auxiliary hydraulic pump (4).
- **Starter/Generator** (3) - connected to the APU engine (2) by a chain. Chain driven by the APU engine (2), the 300-amp 28-volt generator functions as the starter motor. Power from the batteries is used to power the starter/generator when starting the APU. Once the APU is started, the starter/generator generates 28 V dc and delivers it to the voltage regulator (1).
- **Auxiliary Hydraulic Pump** (4) - supplies hydraulic pressure to run the impact wrench, refuel/defuel pump, or raise/lower the spade or boom, and retrieve cables under no load conditions.

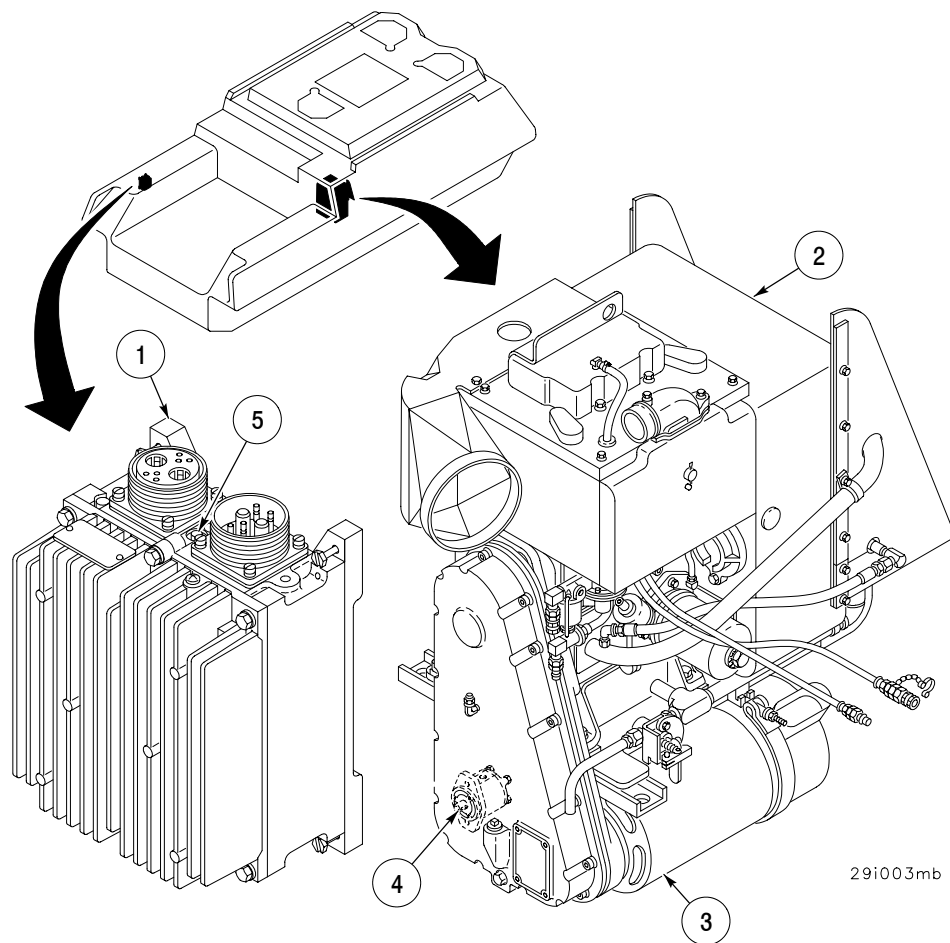

AUXILIARY POWER UNIT (HATZ)

- **Voltage Regulator (1)** - voltage regulator receives 28 V dc from the starter/generator (3) and provides 28 ± 0.7 V dc to charge the vehicle batteries. Voltage regulator (1) is equipped with a resettable circuit breaker. If the circuit breaker opens due to an over voltage condition, the reset button (5) can be pushed to reset the circuit breaker.
- **Engine (2)** - burns fuel drawn from the right rear fuel tank. Engine drives starter/generator (3) and auxiliary hydraulic pump (4).
- **Starter/Generator (3)** - connected to the APU engine (2) by a chain. Chain driven by the APU engine (2), the 300-amp 28-volt generator functions as the starter motor. Power from the batteries is used to power the starter/generator when starting the APU. Once the APU is started, the starter/generator generates 28 V dc and delivers it to the voltage regulator (1) to charge vehicle batteries and supply electrical power to the vehicle.
- **Auxiliary Hydraulic Pump (4)** - supplies hydraulic pressure to run the impact wrench and refuel/defuel pump under normal operations, or raise/lower the spade or boom, and retrieve cables under no load conditions under emergency operations.

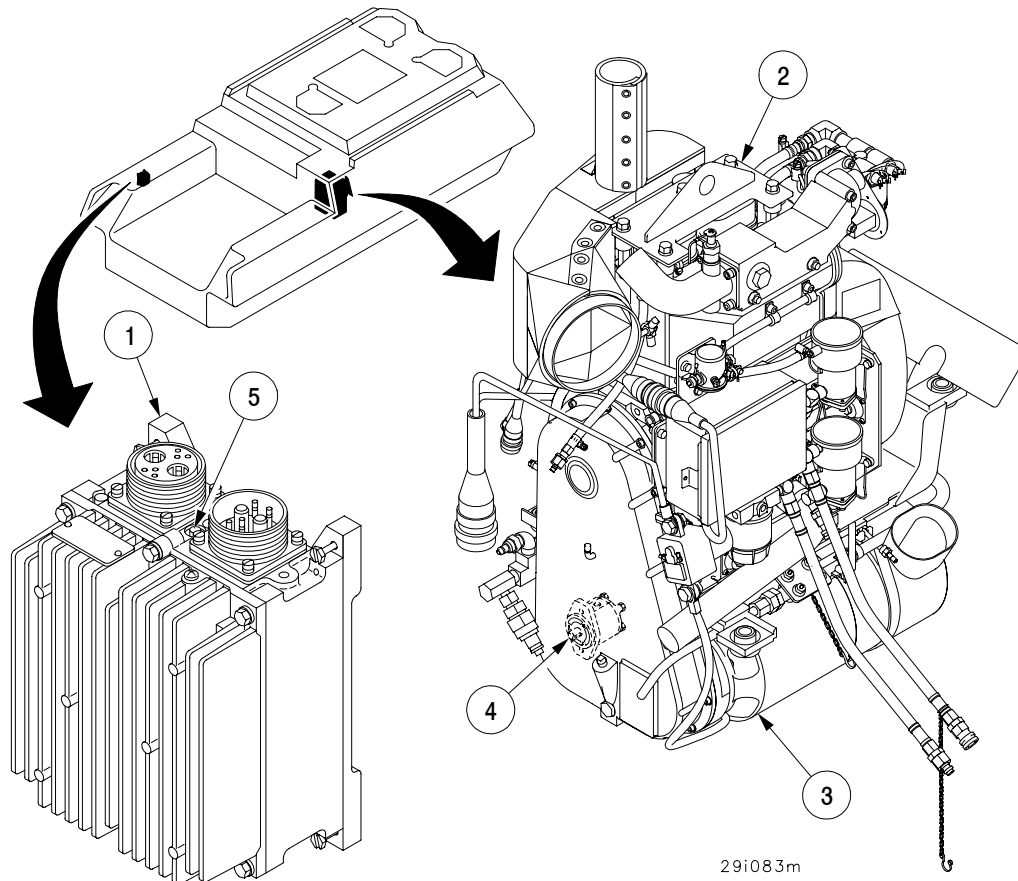

THEORY OF OPERATION - CONTINUED

0005 00

AIR PURIFICATION SYSTEM

- **AIR PURIFICATION UNIT Switch** (1) - located on the front wall of the crew compartment, turns the gas particulate filter units (2) ON or OFF and supplies power to the M3 heaters.
- **Gas Particulate Filter Unit** (2) - supplies filtered air through hoses through the M3 heaters to NBC masks worn by crewmembers. Four NBC hoses can be attached to each gas particulate filter unit.
- **M3 Heaters** (3) - warms air from gas particulate filter unit (2) before entering protective mask.

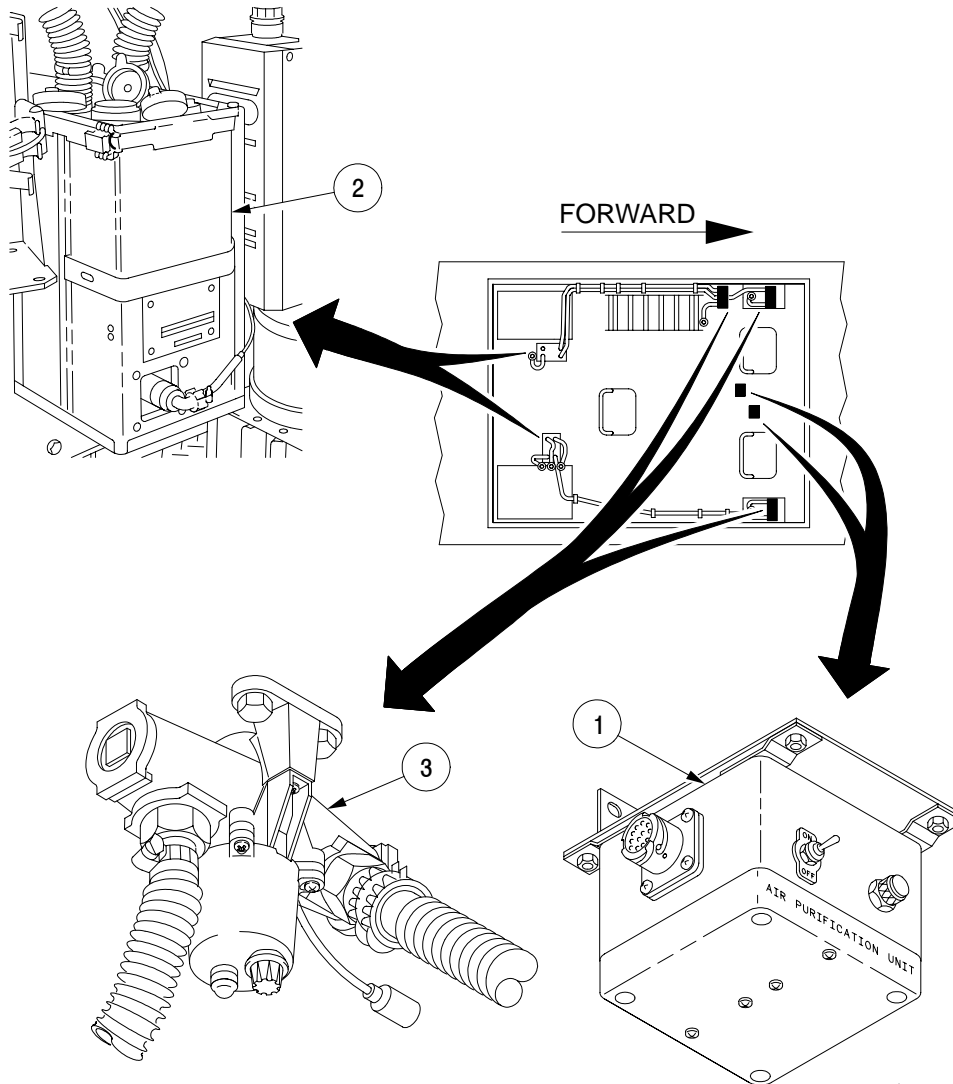

91i001ma

SMOKE GRENADE LAUNCHER SYSTEM, M239

- **Pushbutton Switches (Left and Right)** (1) - fires either the left side or right side pattern of smoke grenades by applying 28 V dc to the smoke grenade discharge tubes (4).
- **Indicator Light** (2) - lights when smoke grenade launcher system is activated.
- **Arming Switch** (3) - activates the smoke grenade launcher system by applying 28 V dc to the smoke grenade launcher indicator light (2) and pushbutton switches (1).
- **Smoke Grenade Discharge Tubes** (4) - located on the left and right front corners of the vehicle. Smoke grenades are loaded into each of the twelve barrels (six per side). When the pushbutton switch (1) is pressed, 28 V dc is applied to the smoke grenades to fire the propellant charge.

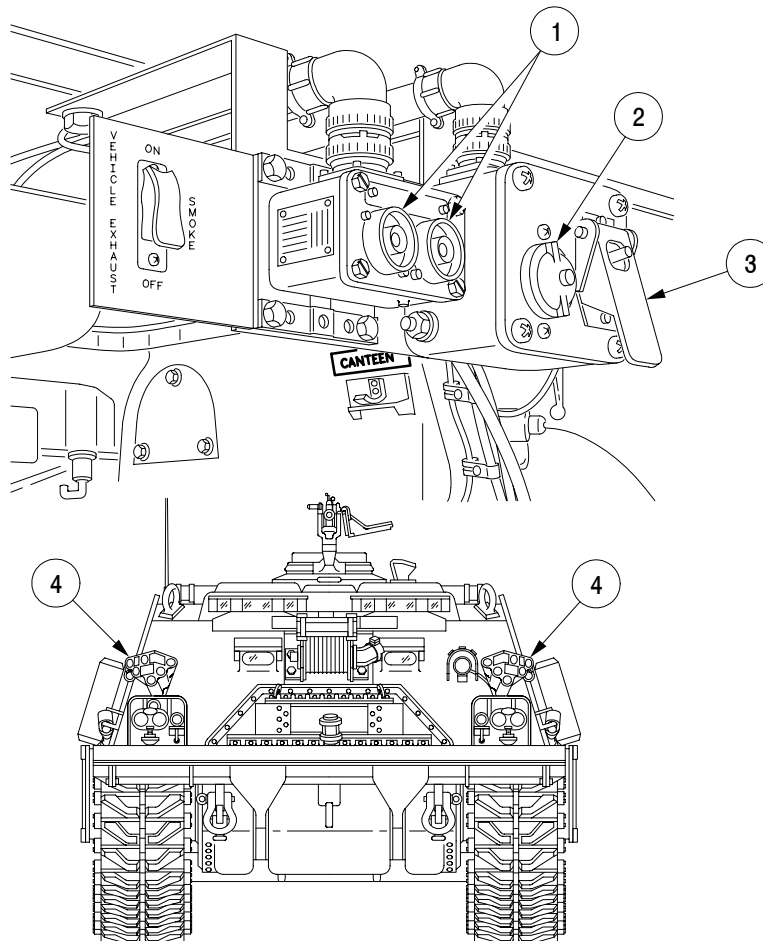

181007ma

THEORY OF OPERATION - CONTINUED

0005 00

DEEP WATER FORDING KIT

- **Main Engine Exhaust Pipes and Clamps** (1) - consist of two flexible, bellowed-type pipes clamped and sealed to the main engine exhaust pipes, routed through access holes in the engine deck, and clamped in place.
- **Air Intake Pipes and Seals** (2) - cover the main engine air intake vents on top of the vehicle.
- **Acetylene Compartment Vent Assembly** (3) - attached to the boss surrounding the four vent holes in the left rear of the cab. It provides ventilation of the acetylene tank compartment during fording operations.
- **Fuel Tank Vent** (4) - sealed and vented using rubber hoses, 90 degree elbows, and clamps.
- **Bilge Pump/Motor** (5) - installed to pump out any water that enters the vehicle during fording operations.

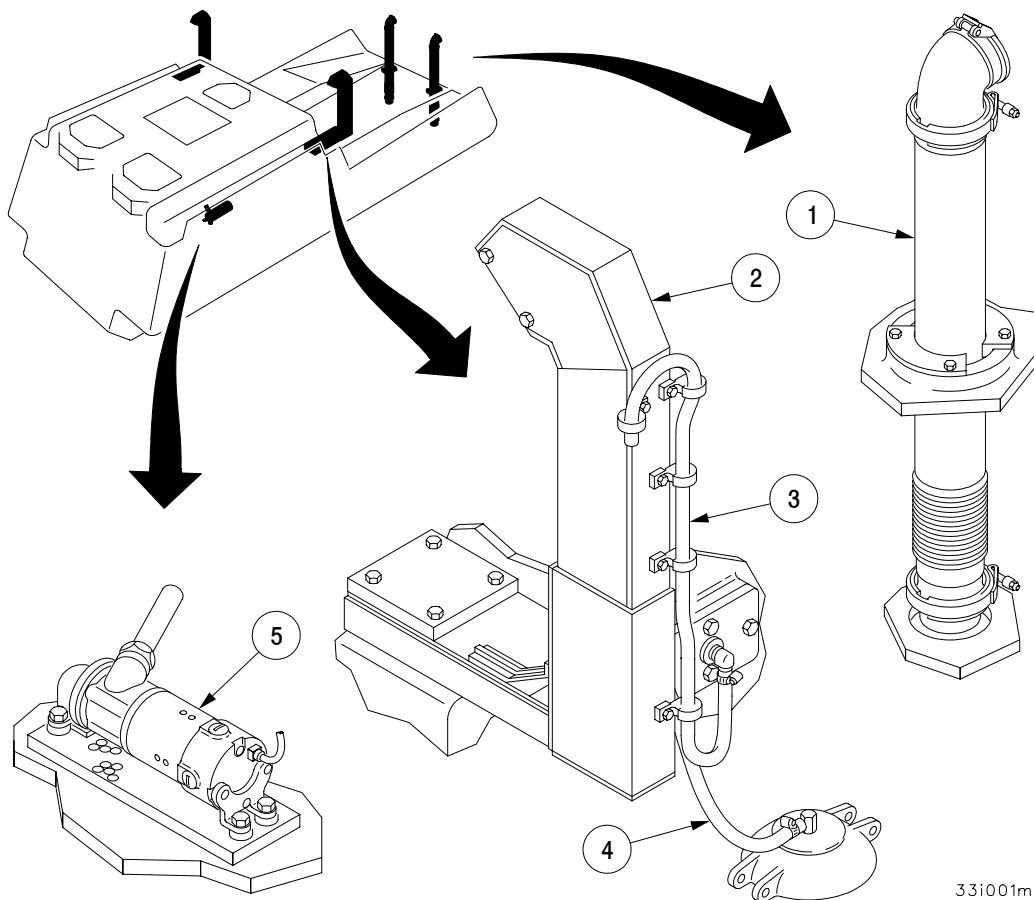

33i001m

DEEP WATER FORDING KIT - CONTINUED

- **APU Exhaust Outlet Sealer Plug (6)** - installed in the APU exhaust outlet to keep water out.
- **Personnel Heater Exhaust Plug (7)** - installed to keep water out.
- **Fire Extinguisher System (FES) Protective Caps (8)** - installed on FES exhaust cones to prevent water from entering the FES tubing.
- **Ventilating Blower Housing Sealing Plate (9) and Boom Foot Drain Clamps (10)** - installed to keep water out.
- **Vehicle Sealing** - Sealing tape, fording sealer, electrical insulation tape, and sealing compound is used to seal and protect storage compartment doors, personnel doors, nose piece, electrical connections, and all other areas exposed to water.

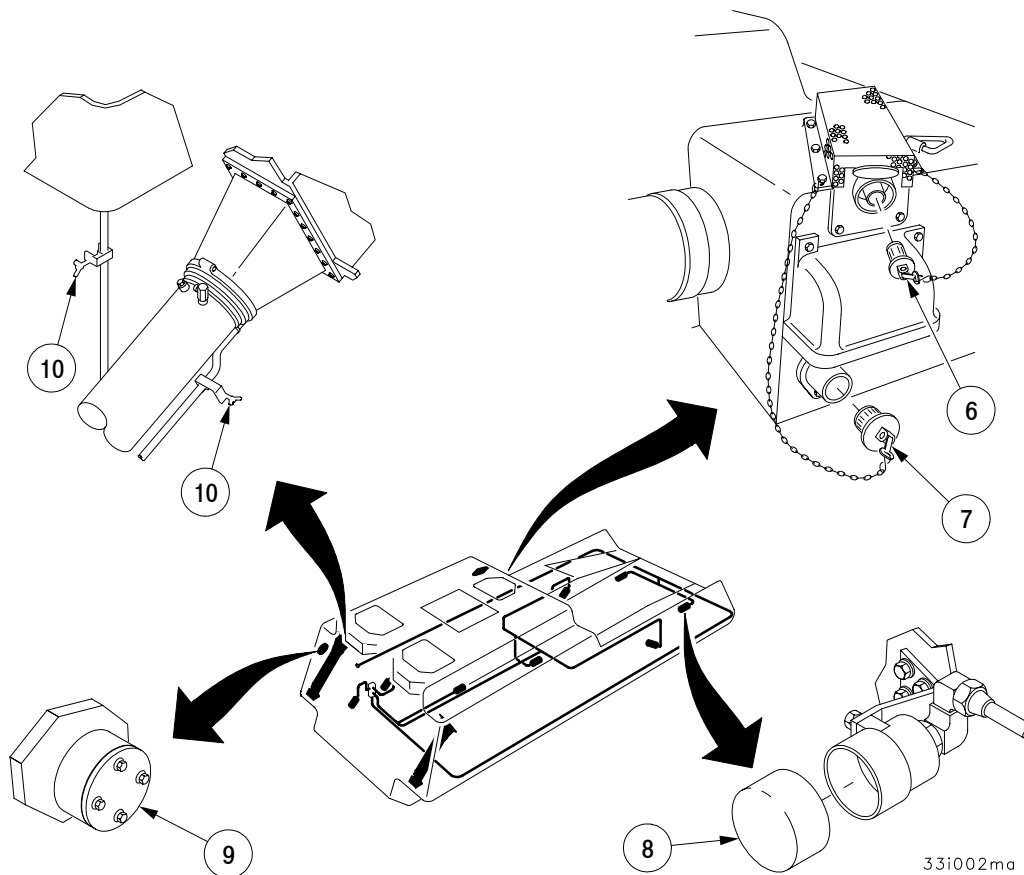

END OF TASK

CHAPTER 2

OPERATOR INSTRUCTIONS

DESCRIPTION AND USE OF OPERATOR'S CONTROLS AND INDICATORS

0006 00

THIS WORK PACKAGE COVERS:

Operator Controls and Indicators

INITIAL SETUP:

References

- TM 11-5830-340-12
- TM 11-5830-263-10

Key	Control or Indicator	Function
1	Turn signal control lever	Controls front and rear directional lights and 4-way hazard lights.
2	Steering wheel	Used to steer vehicle.
3	Horn pushbutton	Sounds vehicle's exterior horn when pressed.
4	Driver's hatch control lever	Used to open/close driver's hatch.
5	BILGE PUMP indicator	Lights green when BILGE PUMP toggle switch is ON.
6	WINCH LIGHT toggle switch	Turns winch lights, under subfloor, ON/OFF.
7	VENT BLOWER toggle switch	Turns personnel ventilation blower ON/OFF.
8	GENERATOR OUT indicator	Lights yellow when GENERATOR toggle switch is up.
9	GENERATOR toggle switch	Normal operating position is down. When toggle switch is up, main engine generator is disabled.
10	Utility power receptacle	Provides 24V dc to any accessory plugged into receptacle.
11	BILGE PUMP toggle switch	Turns bilge pump ON/OFF (when installed).

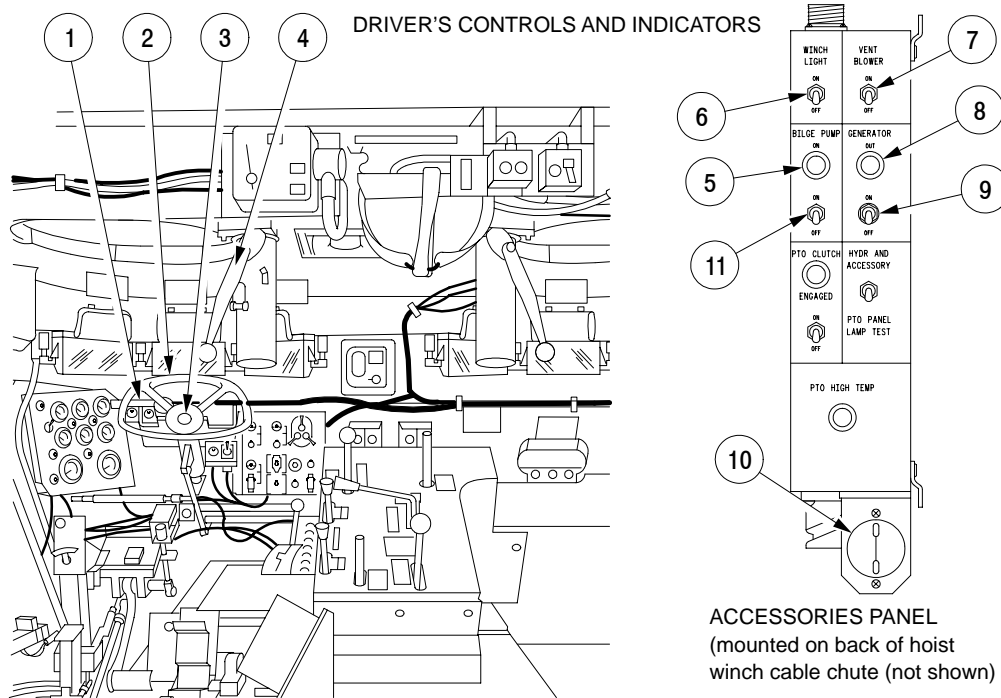

06i012m

**DESCRIPTION AND USE OF OPERATOR'S CONTROLS AND INDICATORS -
CONTINUED**

0006 00

Key	Control or Indicator	Function
12	Dome light switch	Turns either blue or white dome light ON/OFF.
13	Accelerator pedal	Used to control speed of vehicle while driving.
14	Dimmer pushbutton foot switch (old configuration)	Selects either high or low beams when headlights are operating.
15	Brake pedal (old configuration)	Used to slow and stop vehicle.
16	Hull drain control lever	Opens and closes hull drain valves.
17	Manual fuel shut-off handle	Used to stop main engine if electrical system fails. Normal operating position is pushed in. Pull out on handle to shut off fuel flow to main engine.
18	Hand throttle control handle	Used to set main engine speed. Move handle in or out to make coarse adjustments. Twist handle to make fine adjustments.

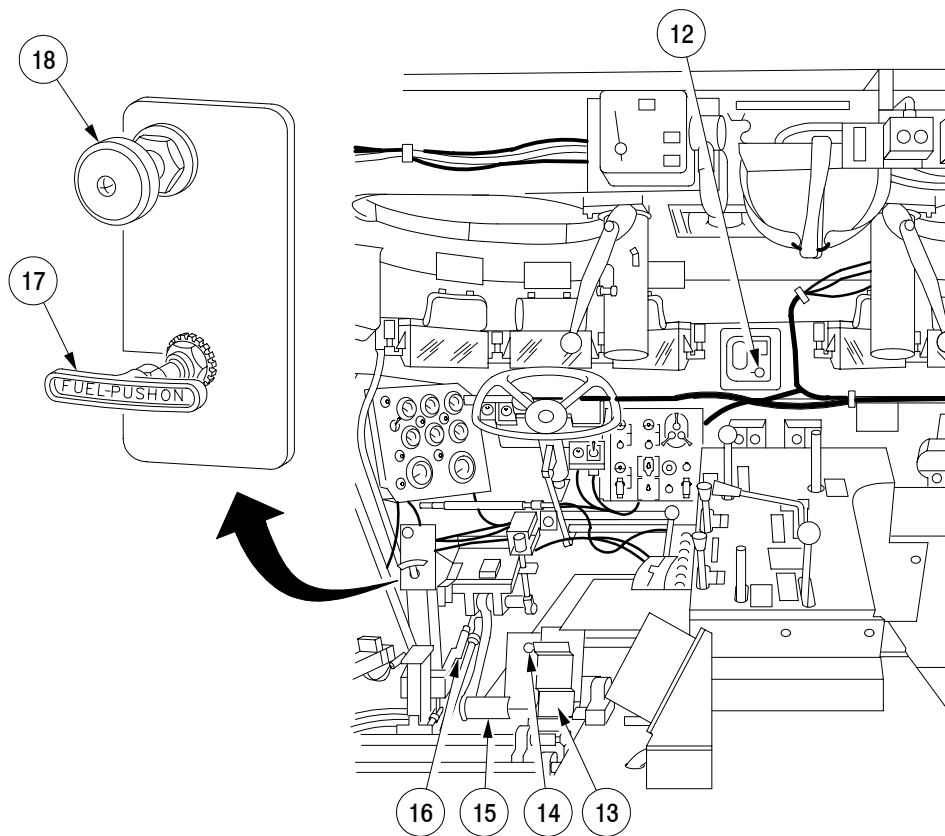

06i013m

**DESCRIPTION AND USE OF OPERATOR'S CONTROLS AND INDICATORS -
CONTINUED**

0006 00

Key	Control or Indicator	Function
19	Dimmer Switch (new configuration with brake modulation)	Selects either high or low beams when headlights are operating.
20	Brake pedal (new configuration with brake modulation)	Used to slow and stop vehicle.

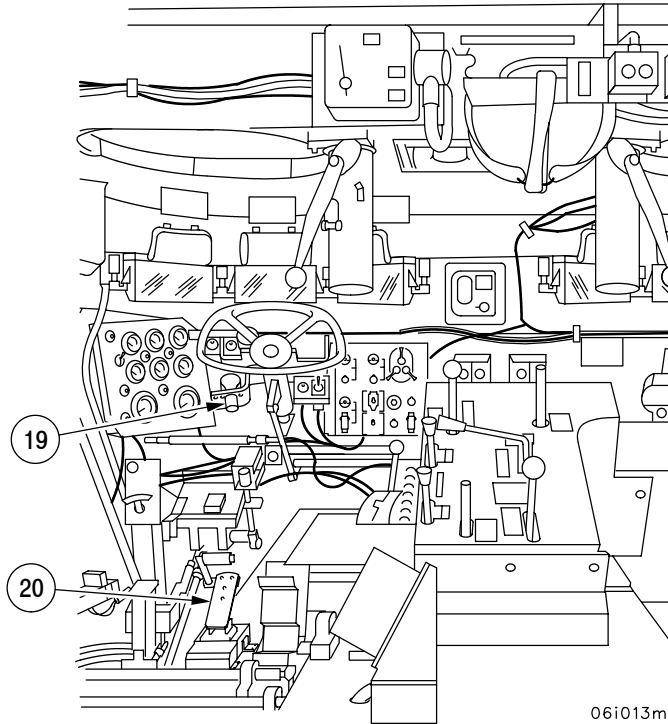

06i013mb

DESCRIPTION AND USE OF OPERATOR'S CONTROLS AND INDICATORS - CONTINUED

0006 00

Key	Control or Indicator	Function
21	FIRE EXTINGUISHER ENGINE SHUTOFF indicator	Lights green when fire extinguisher system pull handle latch is open or ENGINE FUEL SHUTOFF switch is moved to OFF.
22	BATT-GEN INDICATOR gauge	Indicates battery voltage (yellow area) when main engine is off and generator voltage (green area) when main engine is running.
23	ENGINE TEMP °F gauge	Indicates main engine oil temperature in °F (Fahrenheit).
24	ENGINE PRESS gauge	Indicates main engine oil pressure in pounds per square inch (psi).
25	TRANSMISSION PRESS gauge	Indicates transmission oil pressure in psi.
26	Speedometer/odometer	Indicates vehicle speed in MILES PER HOUR (mph) and number of miles traveled.

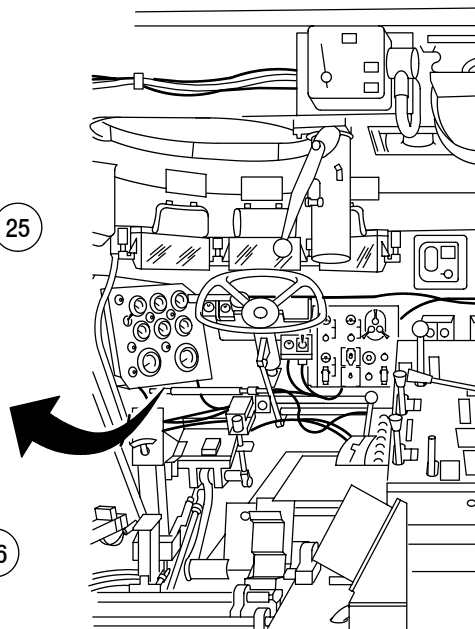
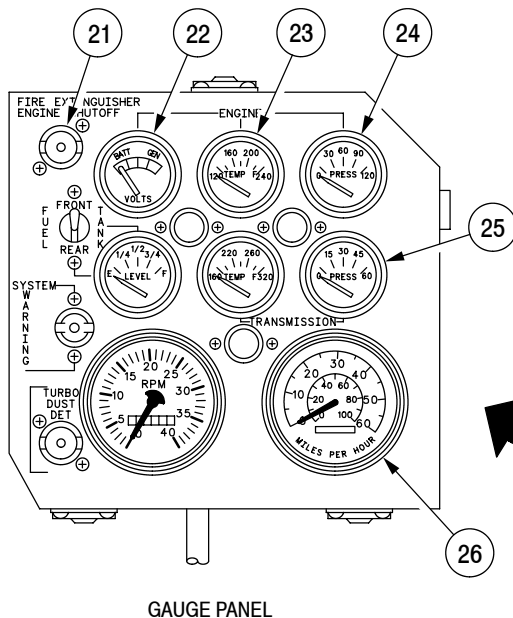

06i014m

DESCRIPTION AND USE OF OPERATOR'S CONTROLS AND INDICATORS - CONTINUED

0006 00

Key	Control or Indicator	Function
27	TRANSMISSION TEMP °F gauge	Indicates transmission oil temp in °F.
28	Tachometer/time meter	Indicates main engine revolutions per minute (RPM) in multiples of 100. Also indicates number of hours main engine has operated.
29	TURBO DUST DET indicator	Lights yellow when engine air intake is contaminated indicating filters need to be serviced, or air intake system is leaking.
30	SYSTEM WARNING indicator	Lights red when: MASTER switch is ON, but main engine is not running; engine oil temperature reaches 240°F; engine oil pressure is less than 13 psi at start or 9 psi when running; transmission oil temperature reaches 260°F; PTO clutch oil temperature reaches 285°F; or brake system pressure drops below 475 psi (old and new brake configuration) or 850-900 psi (new configuration with brake modulation) or below 875 psi (new configuration with enhanced park brake).
31	LEVEL gauge	Indicates fuel level of tank selected by FUEL TANK toggle switch.
32	FUEL TANK toggle switch	Selects either FRONT or REAR fuel tank level to be indicated by LEVEL gauge.

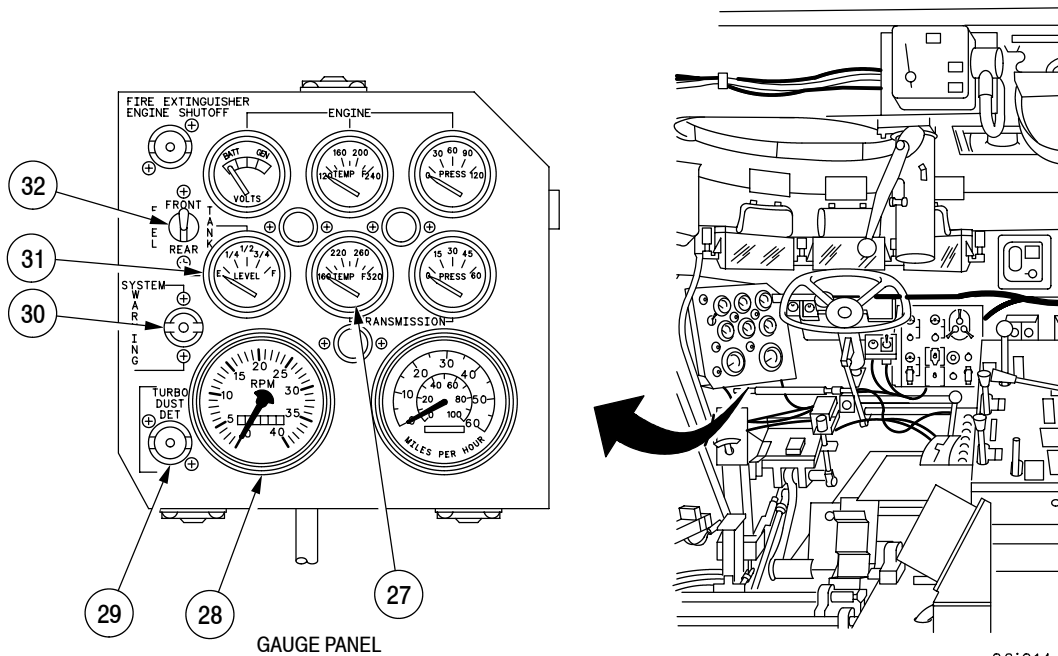

06i014mb

**DESCRIPTION AND USE OF OPERATOR'S CONTROLS AND INDICATORS -
CONTINUED**

0006 00

Key	Control or Indicator	Function
33	Passive night viewer connector	Passive night viewer wiring harness connector connects here to operate viewer from vehicle power.
34	Passive NIGHT VIEWER toggle switch	Supplies 24V dc to passive night viewer connector.
35	Passive NIGHT VIEWER indicator	Lights green when PASSIVE NIGHT VIEWER toggle switch is on.
36	HIGH BEAM indicator	Lights green when high beams are selected by dimmer foot switch.

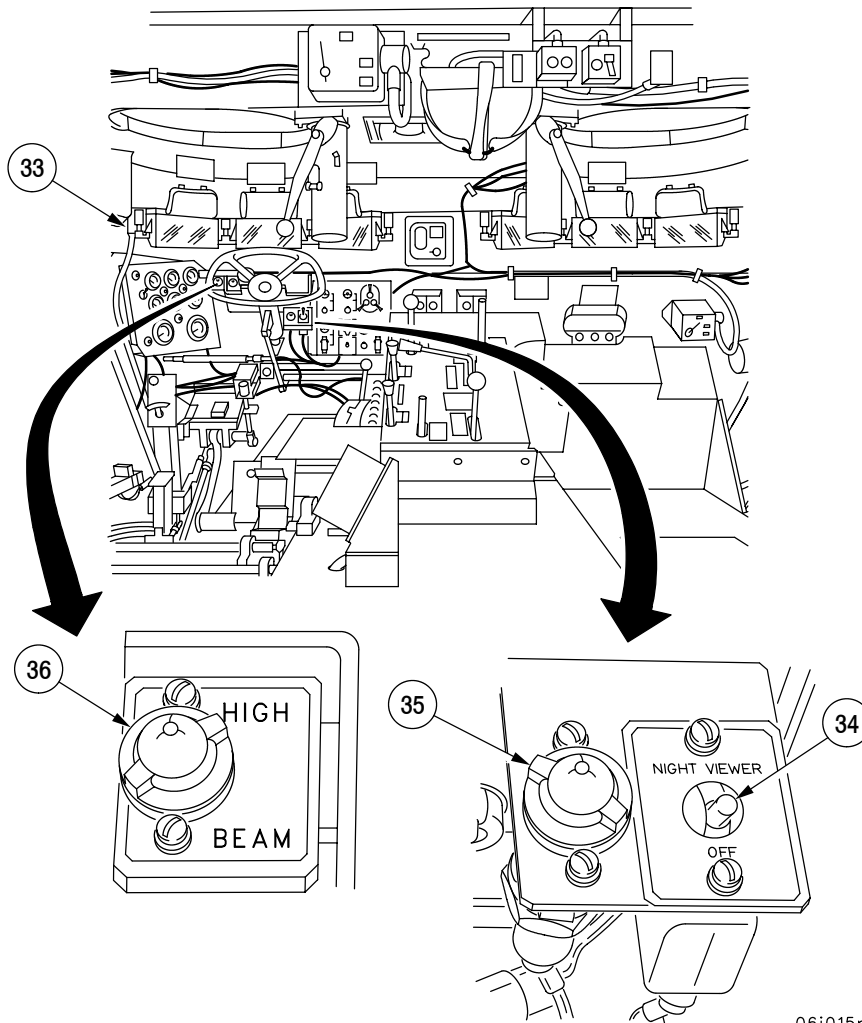

06i015m

DESCRIPTION AND USE OF OPERATOR'S CONTROLS AND INDICATORS - CONTINUED

0006 00

Key	Control or Indicator	Function
37	MASTER toggle switch	When moved to ON, applies battery voltage to electrical systems. When engine is running, it supplies generator voltage to electrical systems. Some vehicles may be equipped with a master switch guard.
38	MASTER toggle switch indicator	Lights green when MASTER toggle switch is ON.
39	Vehicle light switch	Controls vehicle headlights, taillights, blackout marker and drive lights, and internal panel lights.
40	FUEL PUMP toggle switch	Turns electric fuel pump, in forward fuel tank, ON/OFF.
41	START pushbutton	Activates starter motor when pushed.
42	BO SELECTOR toggle switch	Used in conjunction with vehicle light switch to select blackout driving lights.
43	HORN OVERRIDE toggle switch	Disables system warning horn from sounding when a system malfunction occurs.

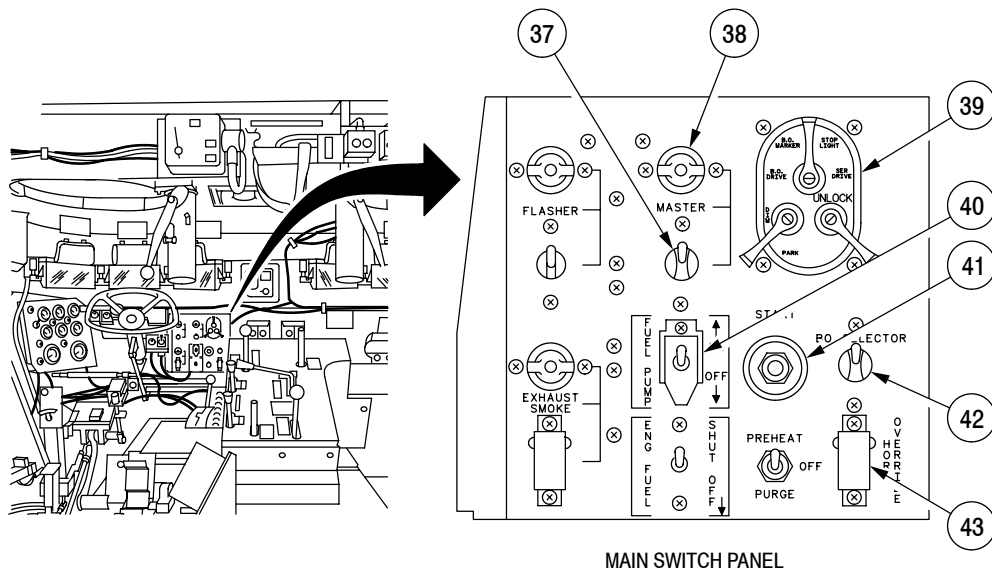

06i016m

DESCRIPTION AND USE OF OPERATOR'S CONTROLS AND INDICATORS - CONTINUED

0006 00

Key	Control or Indicator	Function
44	PREHEAT/PURGE toggle switch	PREHEAT POSITION activates intake manifold heater system to aid in cold-weather starting. The PURGE position activates the purge pump solenoid valve and purge pump to allow air to be purged from the engines main fuel system prior to starting vehicle.
45	ENG FUEL SHUT OFF toggle switch	Controls main engine fuel supply solenoid. Move switch to OFF to shut down main engine.
46	EXHAUST SMOKE toggle switch.	Turns exhaust smoke generating system ON/OFF
47	EXHAUST SMOKE indicator	Lights when EXHAUST SMOKE toggle switch is ON.
48	FLASHER toggle switch	Turns front flasher warning light ON/OFF.
49	FLASHER indicator	Lights when FLASHER toggle switch is ON.
50	Brake bleed valve handle	Bleeds air from the hydraulic brake lines back to the hydraulic reservoir.
51	Brake pressure gauge	Indicates brake hydraulic pressure.

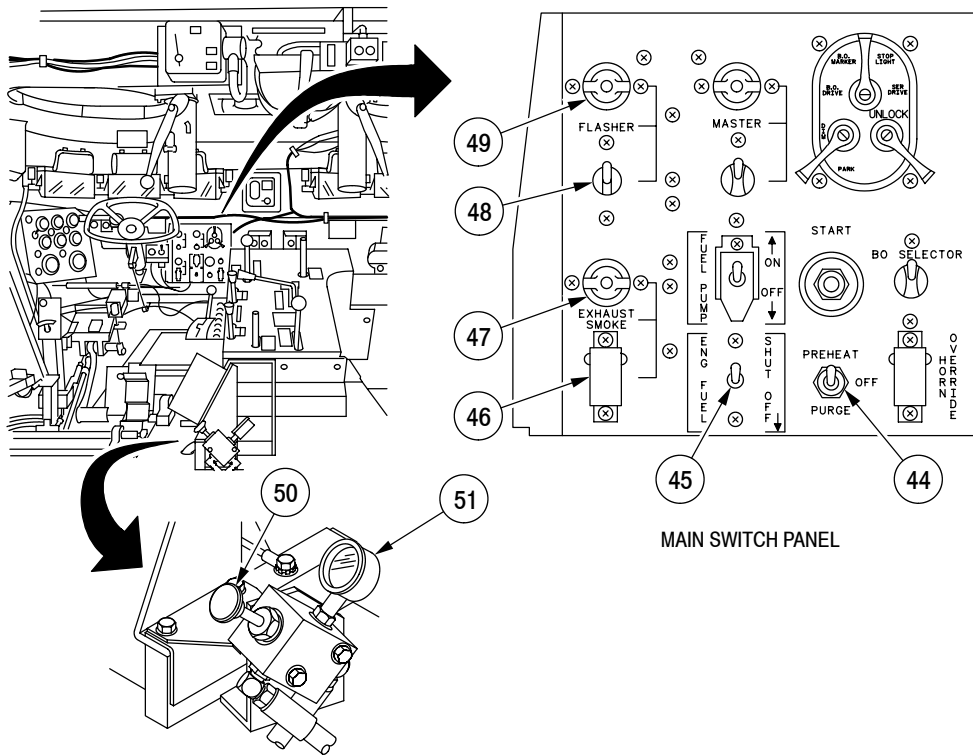

06i016mc

DESCRIPTION AND USE OF OPERATOR'S CONTROLS AND INDICATORS - CONTINUED

0006 00

Key	Control or Indicator	Function
52	MAX OIL TEMP EXCEEDED (225°F) indicator	Lights red when hydraulic oil temperature reaches 225°F (107°C).
53	LOW OIL LEVEL indicator	Lights red when hydraulic reservoir oil level is low.
54	CHARGE FILTER CLOGGED indicator	Lights yellow when charge filter needs service.
55	RETURN FILTER CLOGGED indicator	Lights yellow when return filter needs service.
56	WINCH TEST toggle switch	Lights SYSTEM WARNING indicator and sounds warning horn and disables main winch with engine running.
57	Transmission shift control handle	Used to select transmission gears: reverse (R), first (1st), second (2nd), third (3rd), and neutral/park (P).
58	Parking brake T-handle	Used to release transmission shift control handle from park position (P).

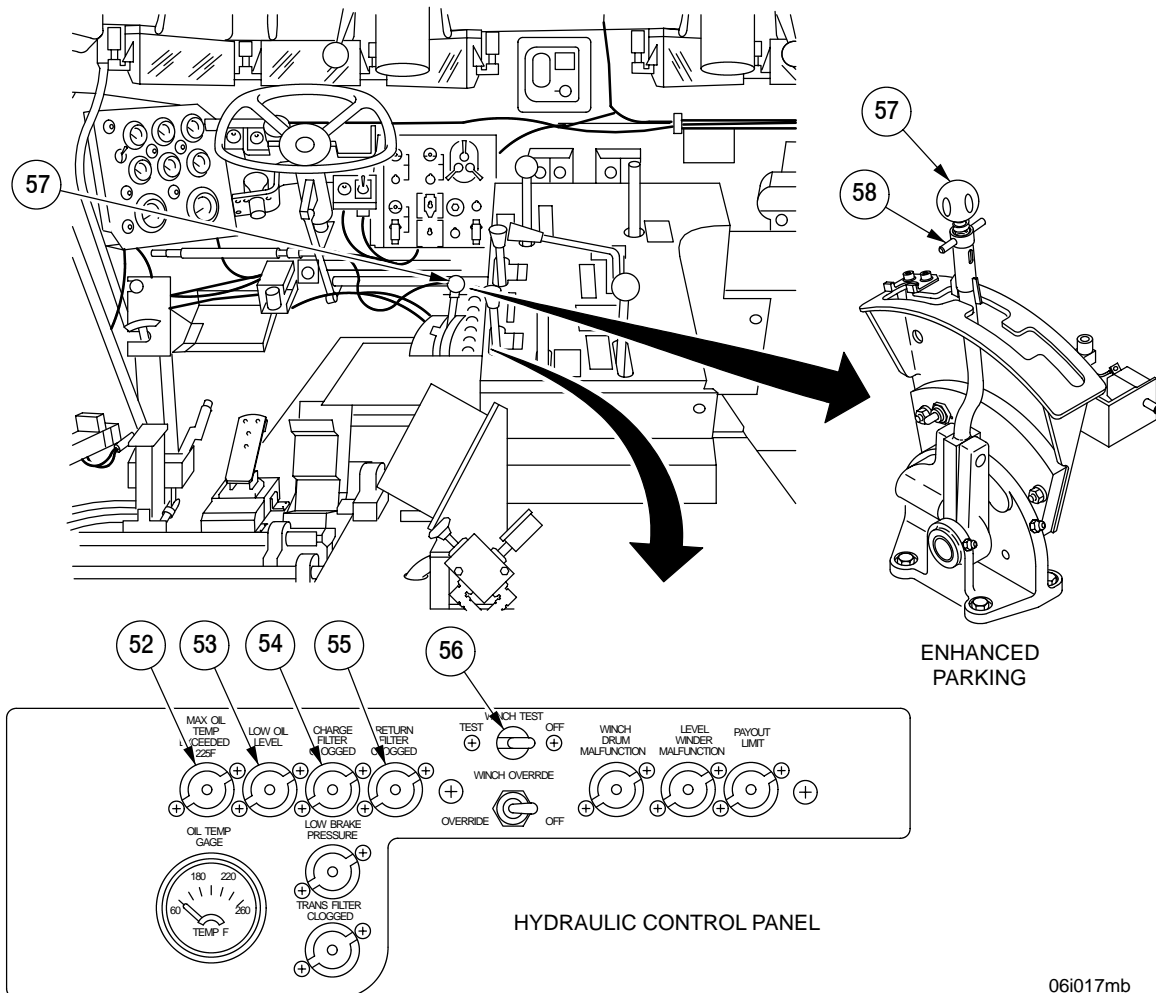

06i017mb

DESCRIPTION AND USE OF OPERATOR'S CONTROLS AND INDICATORS - CONTINUED

0006 00

Key	Control or Indicator	Function
59	PAYOUT LIMIT indicator	Lights yellow when there are only four wraps left on main winch drum.
60	LEVEL WINDER MalfUNCTION indicator	Lights yellow when a malfunction with level winder is detected.
61	WINCH DRUM MalfUNCTION indicator	Lights yellow when a malfunction with main winch cable is detected.
62	WINCH OVERRIDE toggle switch	Overrides automatic cutout switches which allows main winch to operate while correcting a malfunction.
63	LOW BRAKE PRESSURE indicator	Lights red when brake system pressure drops below 475 psi (3275 Kpa) (old configuration) or 850-900 psi (5861-6206 Kpa) (new configuration with brake modulation) or below 875 psi (new configuration with enhanced park brake).
64	TRANS FILTER CLOGGED indicator	Lights yellow when transmission filter needs service.
65	OIL TEMP GAUGE	Indicates hydraulic oil temperature in °F.

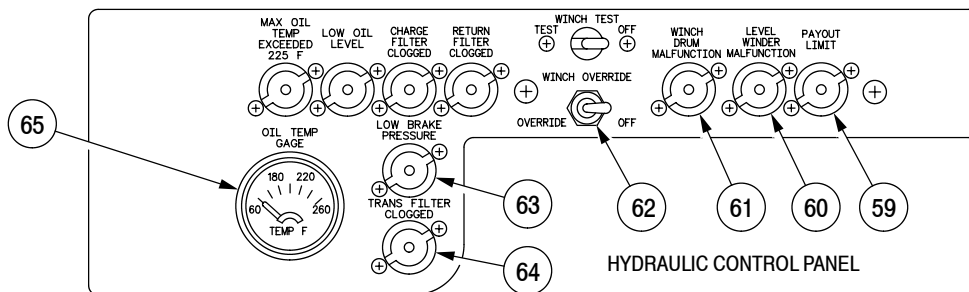
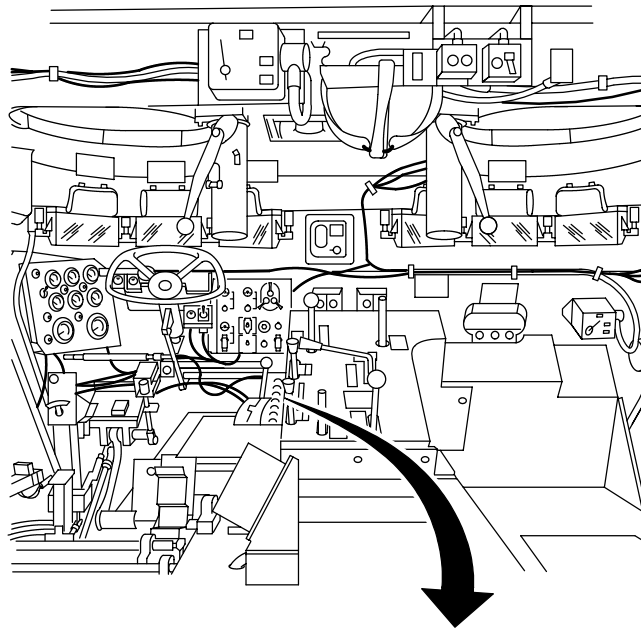

06i017ma

**DESCRIPTION AND USE OF OPERATOR'S CONTROLS AND INDICATORS -
CONTINUED**

0006 00

Key	Control or Indicator	Function
66	Door, Sliding	When open, allows operator to view the main winch cables.
67	Plungers	When pulled, allows operator to move the sliding door.

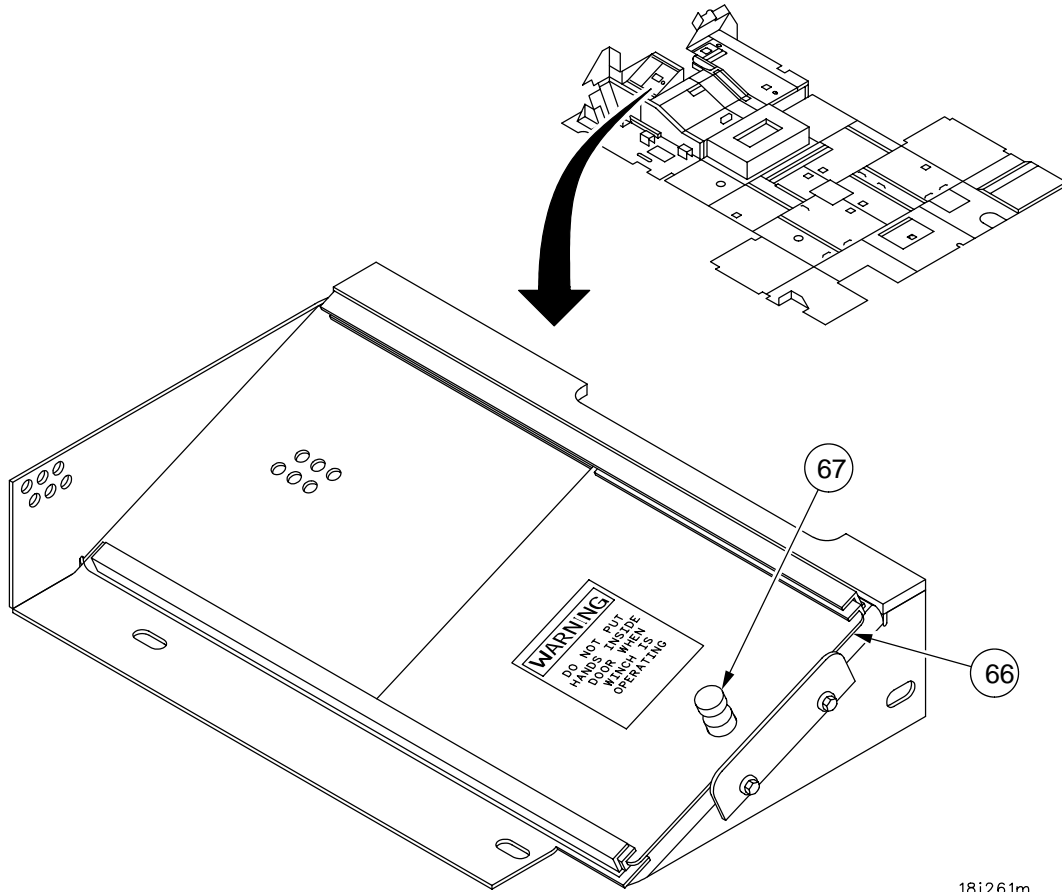

18i261m

**DESCRIPTION AND USE OF OPERATOR'S CONTROLS AND INDICATORS -
CONTINUED**

0006 00

Key	Control or Indicator	Function
68	BOOM operating lever	Controls FORWARD and RETRACT motion of boom when in live boom position. Controls deploy and stow motion of boom in conjunction with BOOM SAFETY directional control valve.
69	SYSTEM SELECTOR control valve handle	Selects between MAIN hydraulic system, auxiliary (AUX) hydraulic system, or refuel/defuel (REFUEL) and impact wrench operations.
70	SPADE bidirectional control valve handle	Controls LOWER and RAISE motion of spade.
71	AUX WINCH bidirectional control valve handle	Controls PAYOUT and INHAUL motion of auxiliary winch cable.
72	BOOM SAFETY directional control valve handle	Used in conjunction with BOOM bidirectional control valve handle to raise and lower boom from STOW position.
73	HOIST WINCH bidirectional control valve handle	Controls LOWER and RAISE motion of hoist winch cable.
74	MAIN WINCH bidirectional control valve handle	Controls PAYOUT and INHAUL motion of main winch cable.

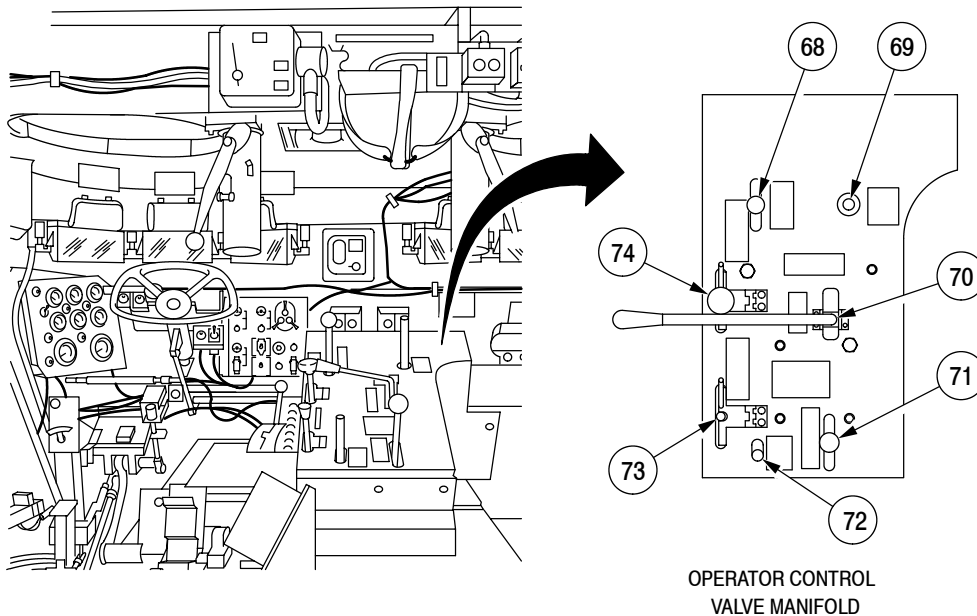

24i009m

DESCRIPTION AND USE OF OPERATOR'S CONTROLS AND INDICATORS - CONTINUED

0006 00

Key	Control or Indicator	Function
75	HIGH AIR TEMP indicator	Lights red when APU air temperature reaches 394°F (201°C) (446°F(230°C)HATZ).
76	LOW OIL PRESS indicator	Lights red when APU engine oil pressure drops below 14±2 psi. (96 kpa)
77	APU control panel light	Illuminates APU control panel.
78	ENGINE OIL PRESS gauge	Indicates APU engine oil pressure in psi.
79	PTO CLUTCH ENGAGED indicator	Lights green when PTO CLUTCH toggle switch is on
80	LAMP TEST momentary toggle switch	Lights indicator lamps on PTO/ACCESSORY panel and hydraulic control panel
81	PTO CLUTCH toggle switch	Engages/disengages electromagnetic clutch when ON/OFF
82	PTO HIGH TEMP indicator	Lights red when electromagnetic clutch oil temperature reaches 285°F (141°C)
83	START momentary toggle switch	Hold in momentary on (MOM ON) position to start APU.
84	PREHEAT momentary toggle switch	Hold in momentary on (MOM ON) position to preheat glow plugs in APU during startup.
85	FUEL SHUT OFF toggle switch	Used to shut off APU by turning off solenoid.
86	APU GEN toggle switch	Engages/disengages APU generator from electrical system when ON/OFF.
87	SPADE LOCK release pushbutton	Retracts spade lock when pressed so spade can be lowered.
88	Parking brake circuit breaker	Protects parking brake electrical circuit (5A)

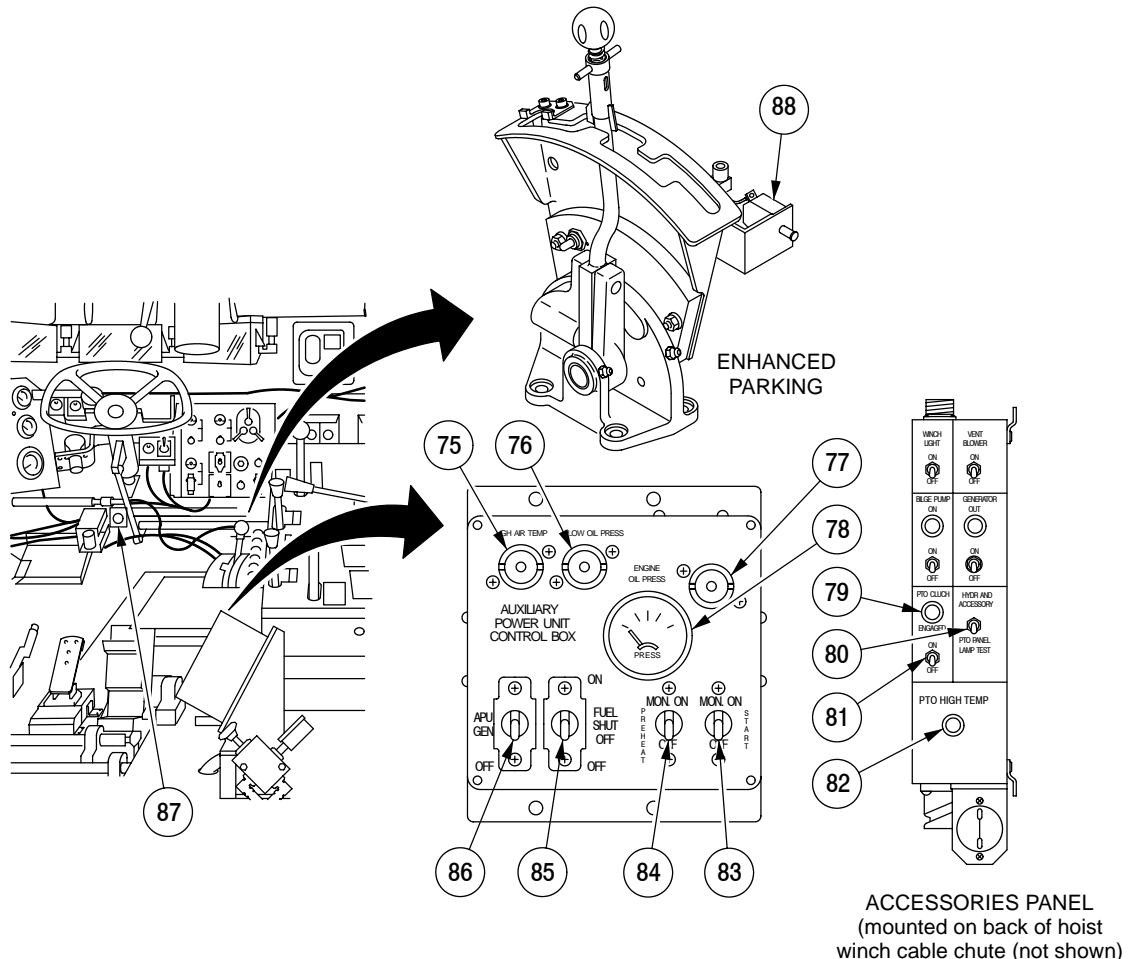

06i018mb

**DESCRIPTION AND USE OF OPERATOR'S CONTROLS AND INDICATORS -
CONTINUED**

0006 00

Key	Control or Indicator	Function
89	HEATER CONTROL HI LO toggle switch	Selects either HI or LO heat range of the personnel heater.
90	HEATER CONTROL indicator	Press indicator to test lamp. Lights yellow approximately two minutes after HEATER CONTROL toggle switch is held to START position.
91	HEATER CONTROL toggle switch	Holding HEATER CONTROL toggle switch to START for two minutes, starts personnel heater. Toggle switch is moved to RUN after indicator lamp lights. Move toggle switch to OFF to shut off personnel heater. If vehicle is equipped with a Global A20 heater, the control toggle switch is moved to START momentarily and then moved to RUN. The heater will then automatically control itself.
92	AN/VIC-1(V) Communications panel	See TM 11-5830-340-12
93	AN/VIC-3(V) Communications panel	See TM 11-5830-263-10
94	M3 HEATER rheostat	Controls air temperature from M3 heater to protective mask.

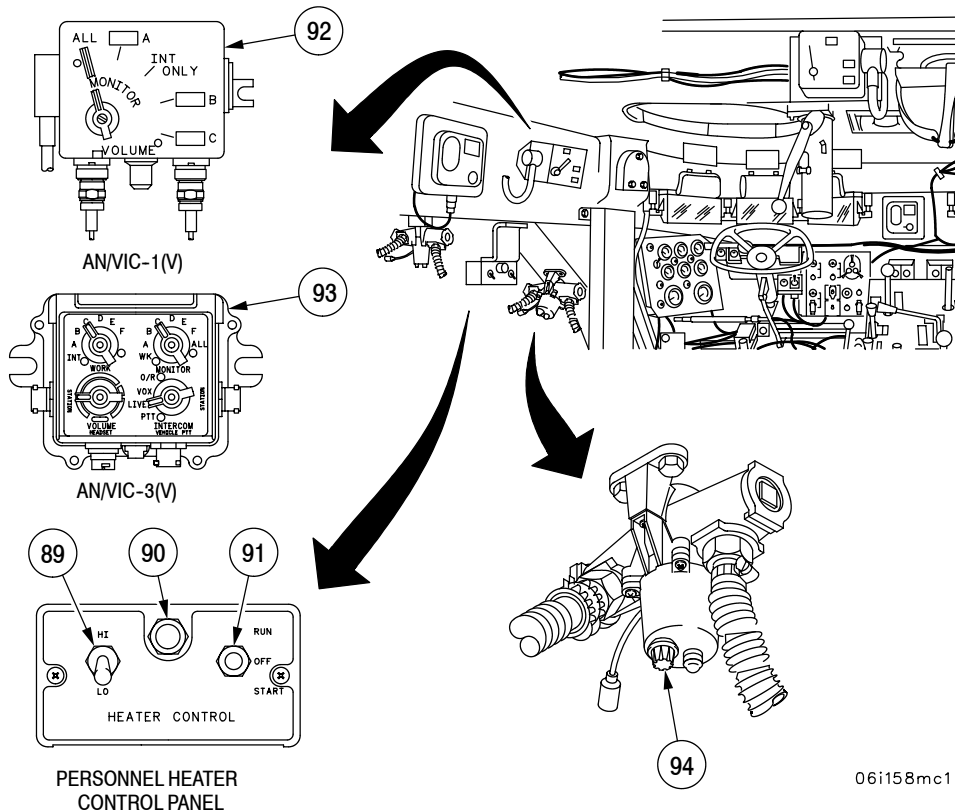

06i158mc1

**DESCRIPTION AND USE OF OPERATOR'S CONTROLS AND INDICATORS -
CONTINUED**

0006 00

Key	Control or Indicator	Function
95	Vertical seat adjustment lever	Controls raise/lower motion of seat.
96	Backrest adjustment lever	Controls raise/lower motion of backrest.
97	Seat dump lever	Controls dump motion of seat.
98	Horizontal seat adjustment lever	Controls the forward/backward motion of seat.

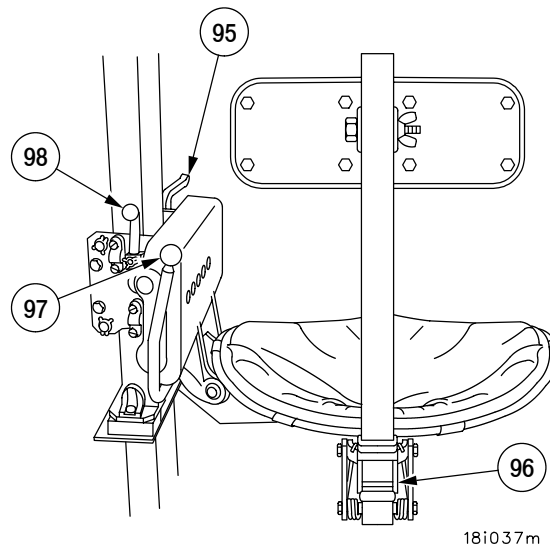

END OF TASK

DESCRIPTION AND USE OF MECHANIC'S CONTROLS AND INDICATORS

0007 00

THIS WORK PACKAGE COVERS:

Operator Controls and Indicators

INITIAL SETUP:

References

- TM 11-5830-340-12
- TM 11-5830-263-10

Key	Control or Indicator	Function
1	Mechanic's hatch control lever	Used to open/close mechanic's hatch.
2	AN/VIC-1(V) Communications panel	See TM 11-5830-340-12
3	AN/VIC-3(V) Communications panel	See TM 11-5830-263-10
4	AIR PURIFICATION UNIT toggle switch	Turns air purification system (gas-particulate filter units and M3 heaters) for mechanic and crew on/off.
5	M3 HEATER rheostat	Controls air temperature from M3 heater to protective mask.

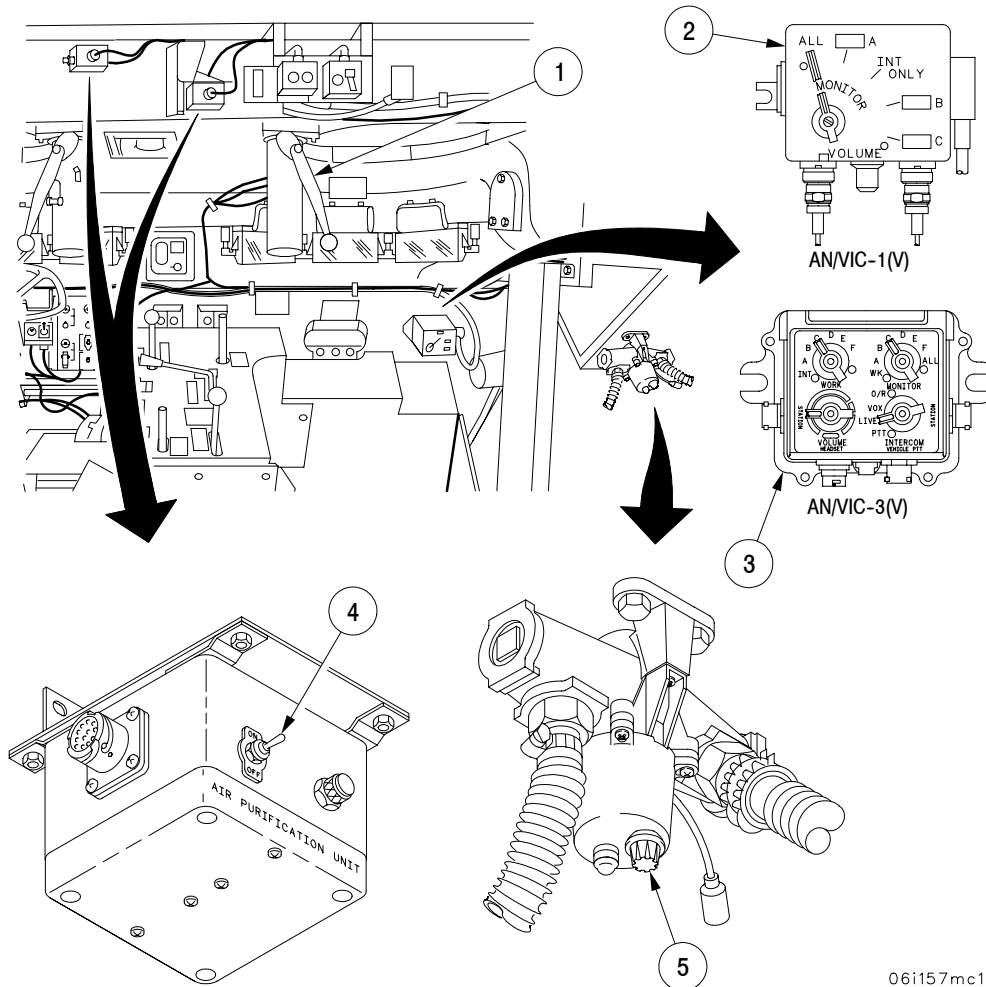

06i157mc1

**DESCRIPTION AND USE OF MECHANIC'S CONTROLS AND INDICATORS -
CONTINUED**

0007 00

Key	Control or Indicator	Function
6	Screw	Loosen or tightens catch (5.2).
7	Catch	Holds covers in place.
8	Handle	Allows mechanic to lift angled cover away from floor plate and view end of main winch drum and limit switches.

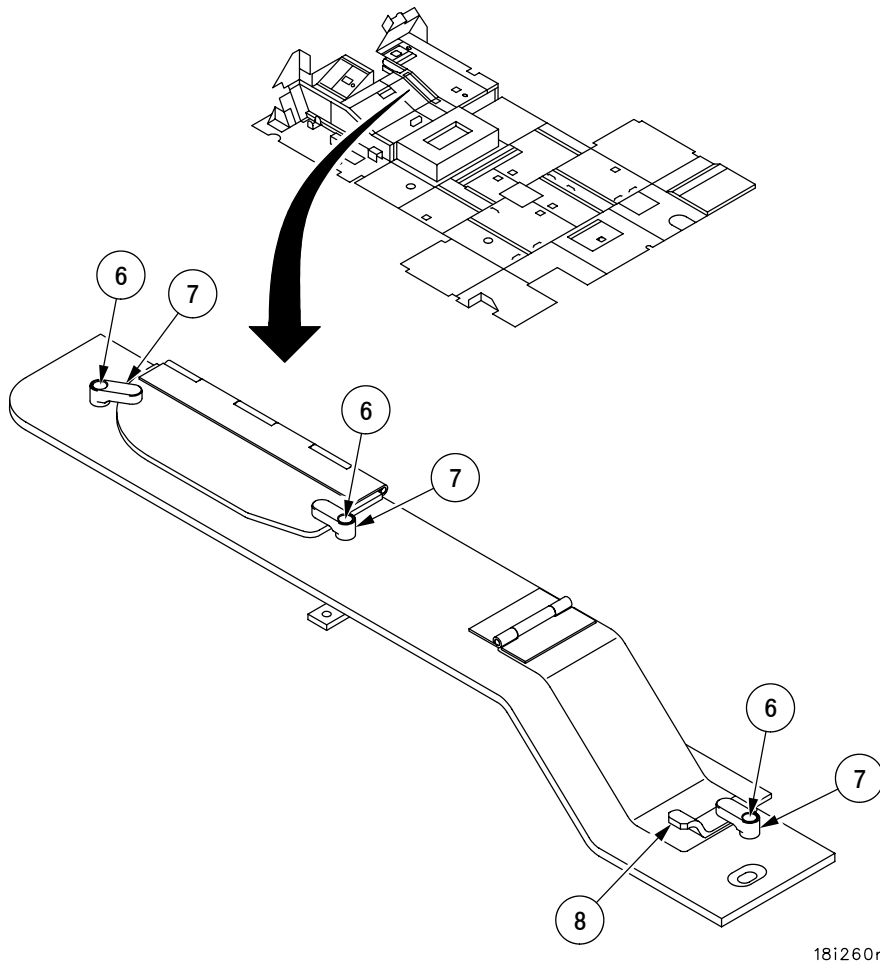

18i260m

DESCRIPTION AND USE OF MECHANIC'S CONTROLS AND INDICATORS - CONTINUED

0007 00

Key	Control or Indicator	Function
9	Vertical seat adjustment lever	Controls raise/lower motion of seat.
10	Horizontal seat adjustment lever	Controls forward/backward motion of seat.
11	Seat dump lever	Controls dump motion of seat.
12	Backrest adjustment lever	Controls raise/lower motion of backrest.

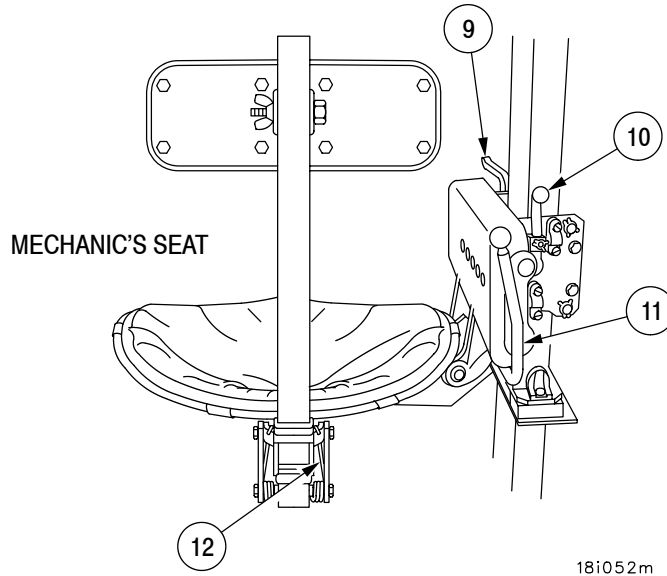

END OF TASK

DESCRIPTION AND USE OF COMMANDER'S CONTROLS AND INDICATORS

0008 00

THIS WORK PACKAGE COVERS:

Commander's Controls and Indicators

INITIAL SETUP:

References

TM 11-5830-340-12

TM 11-5830-263-10

Key	Control or Indicator	Function
1	AN/VIC-1(V) Communications panel	See TM 11-5830-340-12
2	AN/VIC-3(V) Communications panel	See TM 11-5830-263-10
3	VEHICLE EXHAUST SMOKE toggle switch	Turns vehicle exhaust smoke generation system ON/OFF.
4	FIRE SMOKE LEFT and RIGHT pushbutton switches	Fires LEFT or RIGHT discharge pattern of smoke grenades when pressed.
5	SMOKE GRENADE LAUNCHER ARM toggle switch	Arms smoke grenade launchers when switch is in down position.
6	SMOKE GRENADE LAUNCHER ARM indicator	Lights green when ARM toggle switch is in down position.
7	M3 HEATER rheostat	Controls air temperature from M3 heater to protective mask.

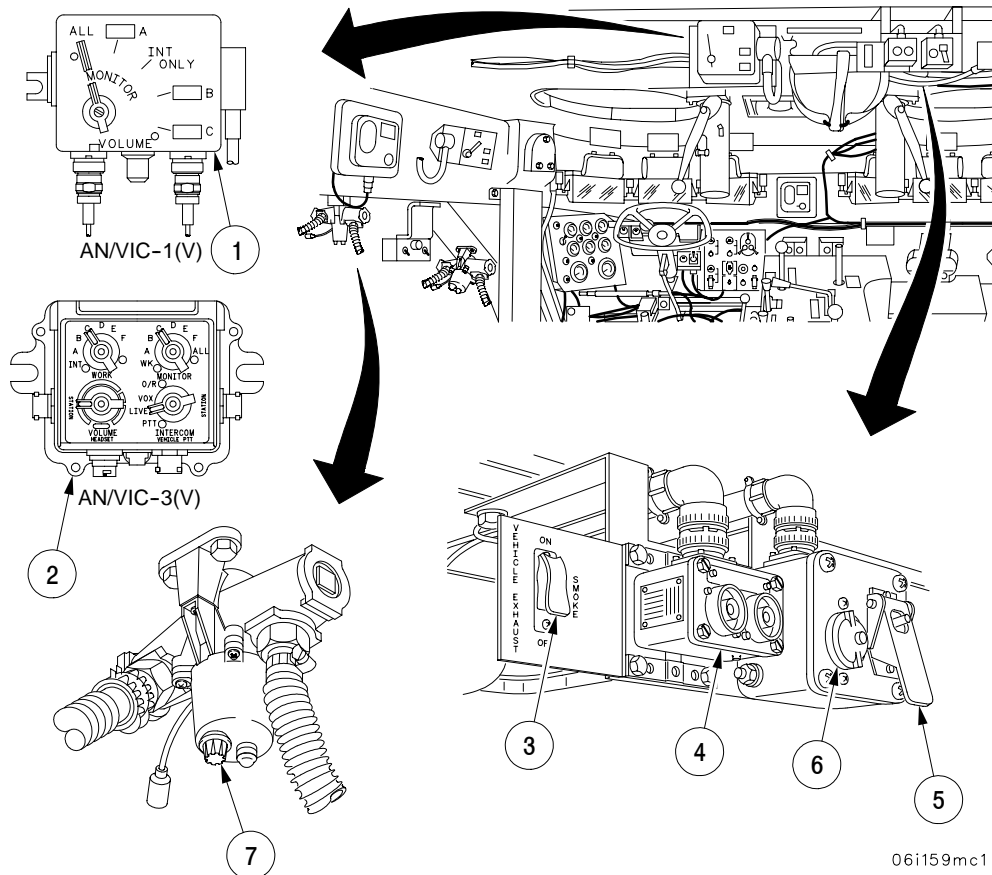

06i159mc1

**DESCRIPTION AND USE OF COMMANDER'S CONTROLS AND INDICATORS
- CONTINUED**

0008 00

Key	Control or Indicator	Function
8	Cupola lock	Locks/unlocks rotation of commander's cupola.
9	Cupola hatch control lever	Locks/unlocks commander's cupola hatch.
10	Seat rotation control lever	Controls seat rotation.
11	Seat dump pin	Controls seat dump.
12	Seat tilt handle	Controls seat back tilt.
13	Height adjustment handle	Controls raise/lower seat position.
14	Horizontal adjustment handle	Controls forward/backward motion of seat.

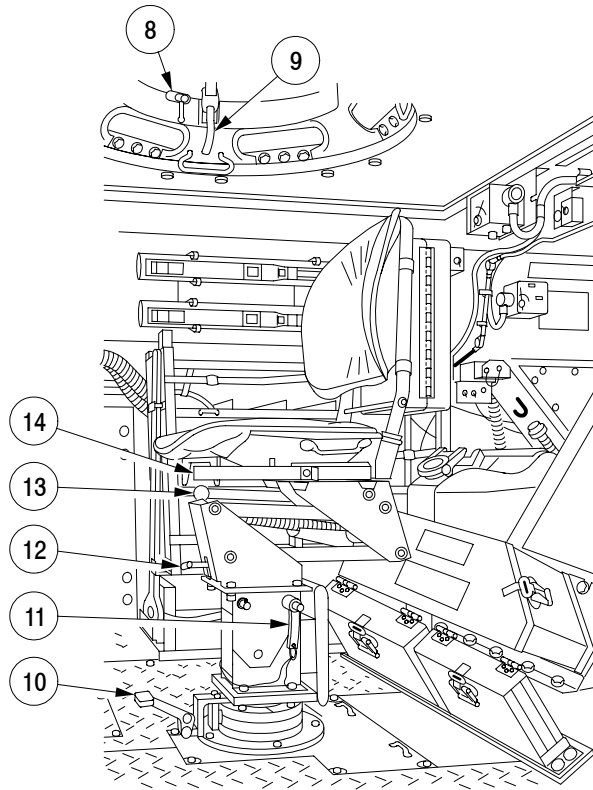

18i033m

**DESCRIPTION AND USE OF COMMANDER'S CONTROLS AND INDICATORS
- CONTINUED**

0008 00

Key	Control or Indicator	Function
15	AN/VIC-1(V) Master control panel	See TM 11-5830-340-12
16	AN/VIC-3(V) Master control panel	See TM 11-5830-263-10
17	AN/VIC-3(V) Loudspeaker	See TM 11-5830-263-10

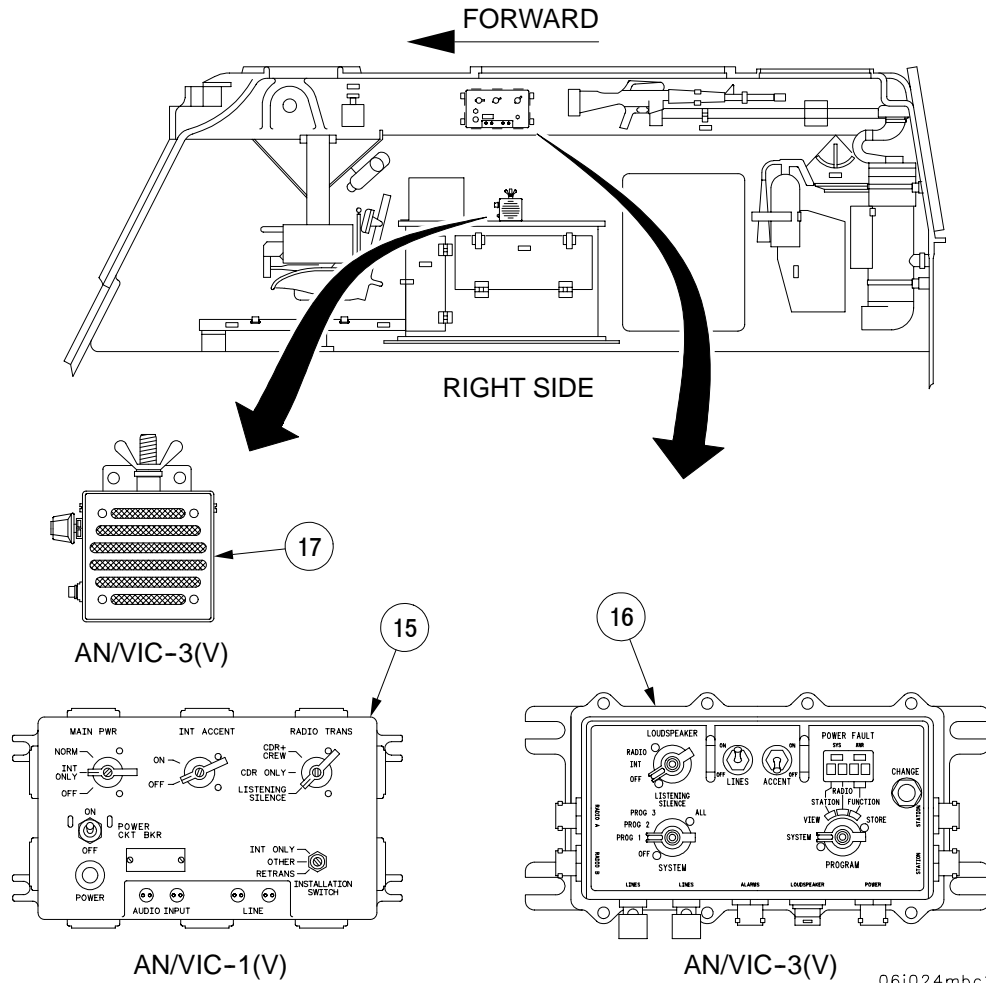

06i024mbc1

END OF TASK

DESCRIPTION AND USE OF PERSONNEL CONTROLS AND INDICATORS

0009 00

THIS WORK PACKAGE COVERS:

Description and use of Personnel Controls and Indicators

INITIAL SETUP:

References

- TM 11-5830-340-12
- TM 11-5830-263-10

Key	Control or Indicator	Function
1	Spotlight elevation control handle	Twist handle to raise/lower spotlight head angle.
2	Spotlight azimuth control mast	Turn mast 360° to rotate spotlight head.
3	Spotlight ON/OFF switch	Turns spotlight ON/OFF.
4	Personnel hatch control lever	Used to open/close personnel hatch.
5	Rear SERVICE light toggle switch	Turns rear service lights ON/OFF.
6	AN/VIC-1(V) Communications panel	See TM 11-5830-340-12
7	AN/VIC-3(V) Communications panel	See TM 11-5830-263-10
8	Troublelight ON/OFF switch	Turns troublelight ON/OFF.
9	Cable lock	Locks troublelight cable in deployed position during use.

PERSONNEL CONTROLS AND INDICATORS

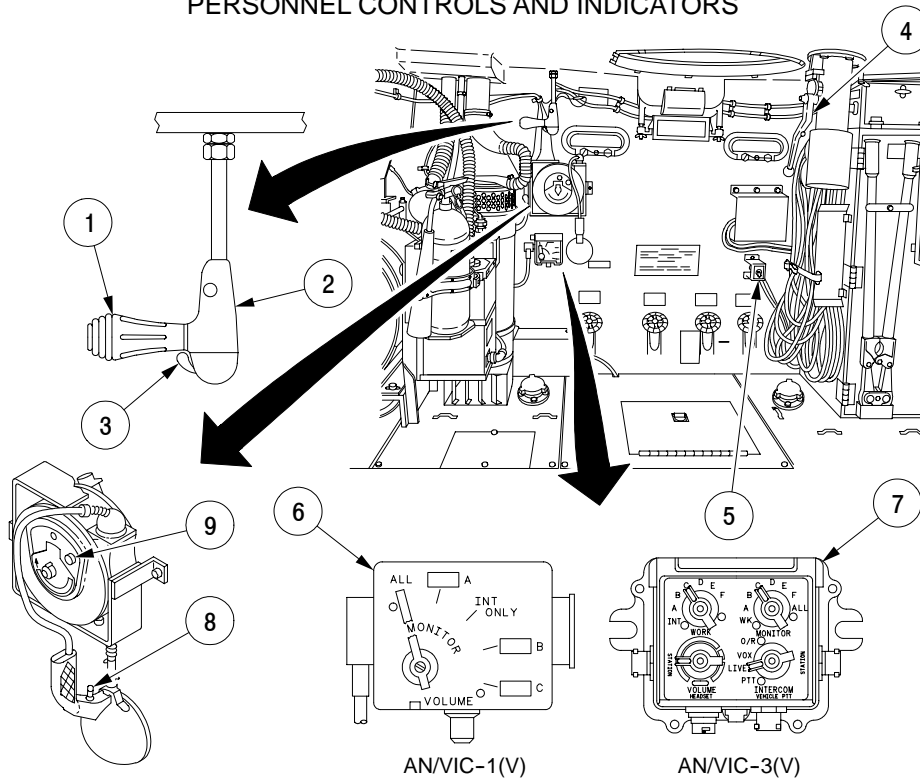

18i053mc1

DESCRIPTION AND USE OF PERSONNEL CONTROLS AND INDICATORS - CONTINUED

0009 00

Key	Control or Indicator	Function
10	FUEL CONTROL VALVE RIGHT REAR TANK	OPENS/CLOSES valve on right rear fuel tank.
11	FUEL CONTROL VALVE FORWARD TANK	OPENS/CLOSES valve on forward fuel tank.
12	FUEL CONTROL VALVE DRAIN	OPENS/CLOSES drain valve to drain fuel tanks.
13	FUEL CONTROL VALVE LEFT REAR TANK	OPENS/CLOSES valve on left rear fuel tank.
14	Air cleaner AIR SOURCE control handles	Two controls, one on either side of crew compartment, are used to select either OUTSIDE or INSIDE air as source for main engine.

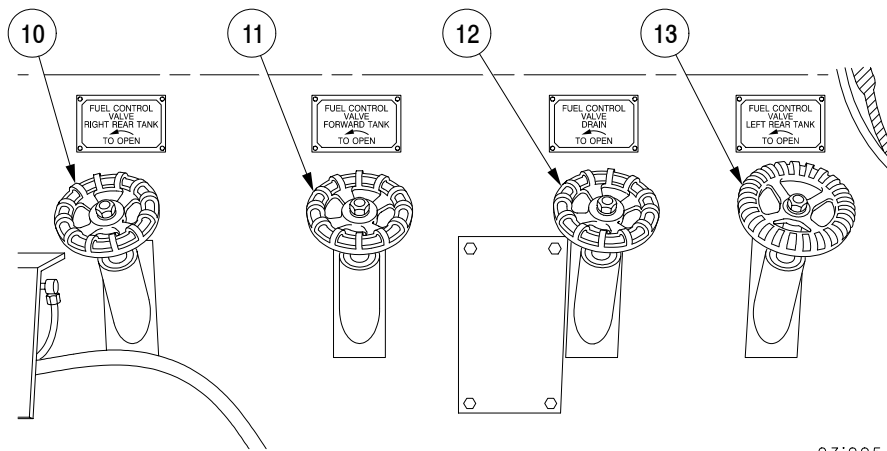

031005m

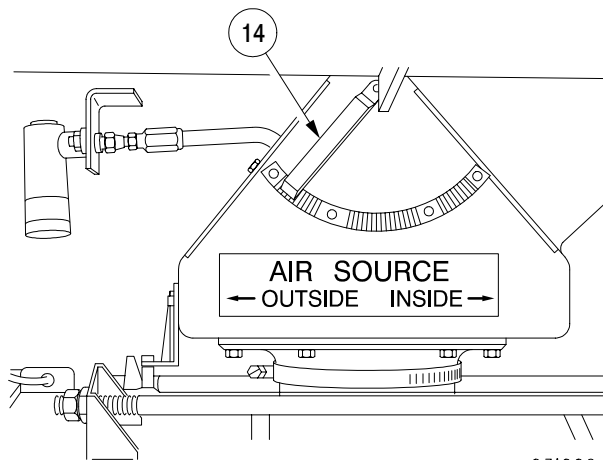

031006m

END OF TASK

ASSEMBLY AND PREPARATION FOR USE

0010 00**THIS WORK PACKAGE COVERS:**Assembly and Preparation for Use, Initial Adjustments, Checks, and Self-Test

INITIAL SETUP:**Tools and Special Tool**

Basic Issue Items (BII) (Table 2, WP 0133 00)

Personnel Required

Three

References

WP 0105 00

WP 0133 00

ASSEMBLY AND PREPARATION FOR USE

When a new vehicle is received by the unit, it must be thoroughly inspected. If anything is wrong with the vehicle, record it on DA Form 2404. Check the vehicle for completeness of assembly. Make sure that all equipment and controls are present and in good shape. Check the Components of End Item (COEI) and Basic Issue Items (BII) against the list in WP 0133 00 to be sure they are all present. Stow all COEI and BII in their designated stowage locations.

INITIAL ADJUSTMENTS, CHECKS, AND SELF-TEST

Perform all BEFORE operation checks and services in the Preventive Maintenance Checks and Services (PMCS) (Table 1, WP 0105 00).

END OF TASK

ENGINE PRESTART OPERATION

0011 00

THIS WORK PACKAGE COVERS:

Engine Prestart Operation

INITIAL SETUP:

Personnel Required

Three

References

- WP 0006 00
- WP 0007 00
- WP 0008 00
- WP 0009 00
- WP 0037 00

1. Before operating the vehicle, become familiar with controls and indicators described in WP 0006 00, WP 0007 00, WP 0008 00 and WP 0009 00.
2. Adjust operator's seat to a comfortable and safe position (WP 0037 00) and fasten seat belt.
3. Check to ensure all doors and hatches are secured and equipment properly stowed.
4. Set following controls to their prestart positions:

MASTER switch (1) - OFF

Vehicle lights switch (2) - OFF

FUEL PUMP switch (3) - ON

PTO/Accessory panel (4) - all switches OFF (GENERATOR switch down)

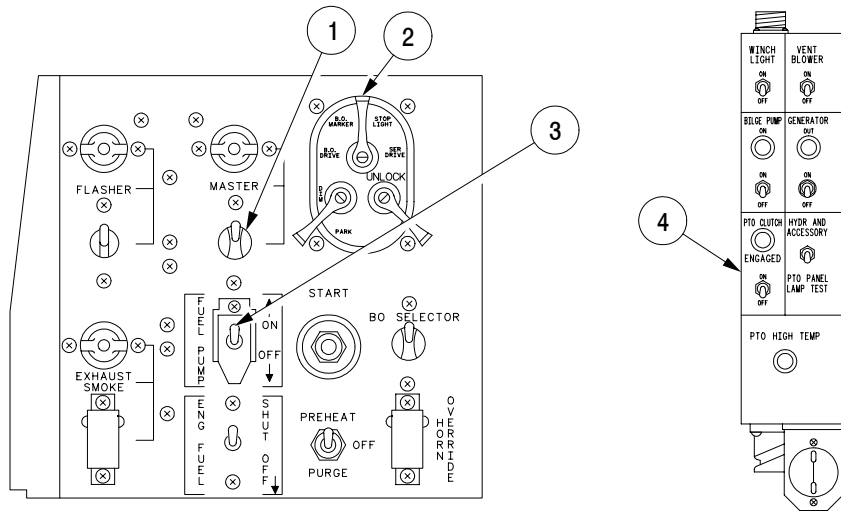

06i036ma

ENGINE PRESTART OPERATION - CONTINUED

0011 00

5. Set following controls to their prestart positions:

Parking brake T-handle (5) engaged to move transmission shift selector (5) to park position.

Transmission shift selector (6) - Park (P)



Make sure brakes are fully applied and locked for parking when holding vehicle on a longitudinal grade of up to 60%. If parking brake fails to hold, do not attempt to park vehicle on slope. Place vehicle on level ground and block track before leaving vehicle. Failure to comply may result in personnel injury/death, impact and/or vehicle/object damage due to collision.

Brake pedal (7) - Depressed and locked (Not applicable to enhanced parking brake configuration).

Hand throttle (8) - Pushed in

Fuel shutoff handle (9) - Pushed in

Dome lights (10) - OFF

Heater control (11) - OFF

Air purifier switches (12) - OFF

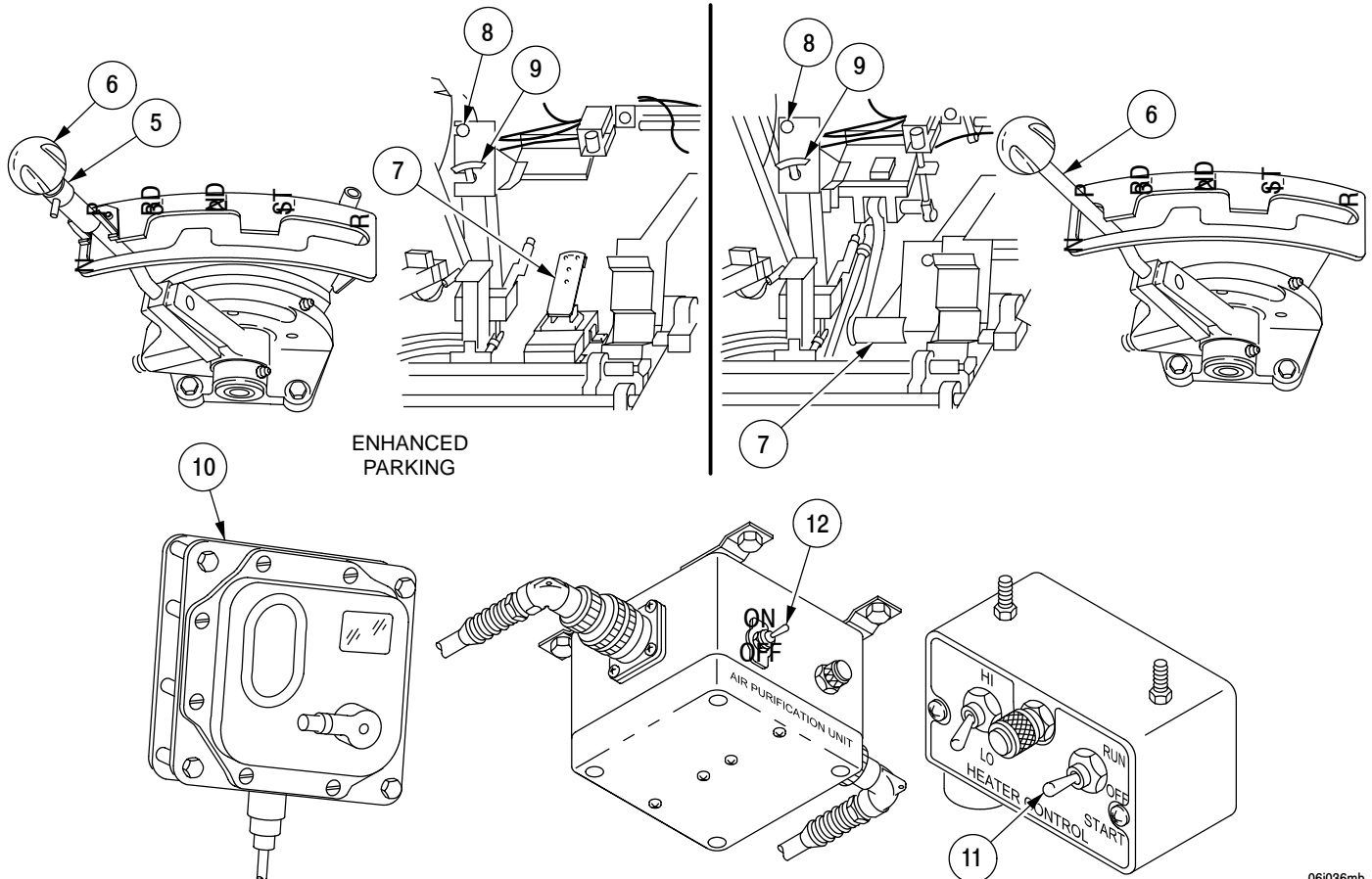

06i036mb

ENGINE PRESTART OPERATION - CONTINUED

0011 00

6. Set following controls to their prestart positions:

NOTE

All levers except SYSTEM SELECTOR are spring loaded and return to NEUTRAL, HOLD or LIVE position automatically.

Hydraulic control valve panel (13) - All levers in HOLD or NEUTRAL. SYSTEM SELECTOR lever in MAIN. BOOM SAFETY lever in LIVE.

Drain valve lever (14) - Down (closed)

PTO CLUTCH toggle switch on the PTO/Accessory panel (15) - OFF

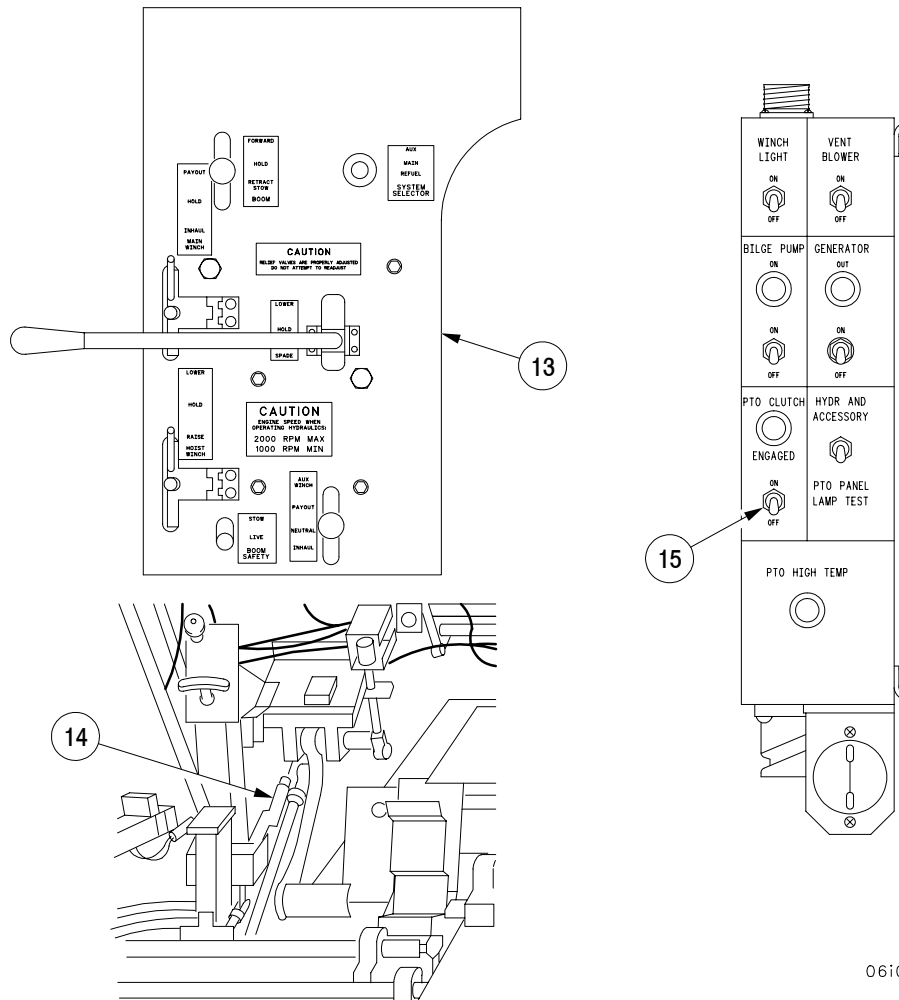

06i012mc

ENGINE PRESTART OPERATION - CONTINUED

0011 00

7. Set following controls to their prestart positions:

Radio communications equipment power switches (16) - OFF

FUEL CONTROL VALVES (17) RIGHT TANK - OPEN; FORWARD TANK CLOSED; DRAIN - CLOSED; and LEFT TANK - OPEN

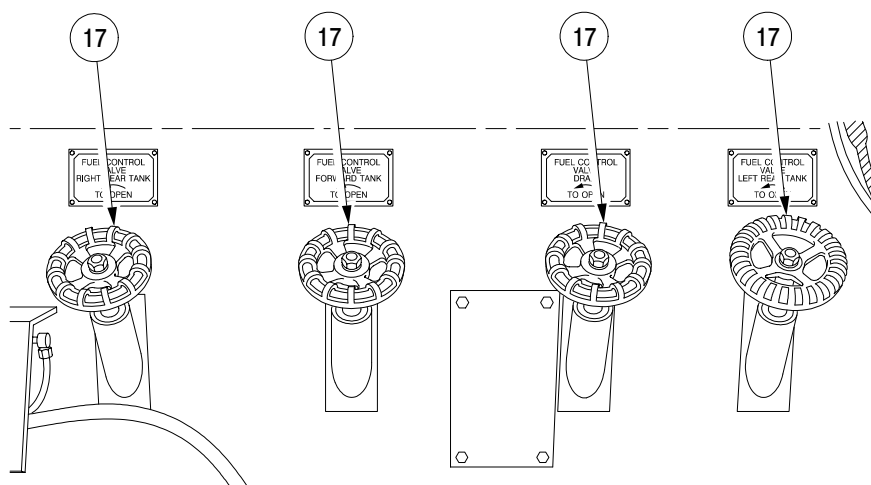
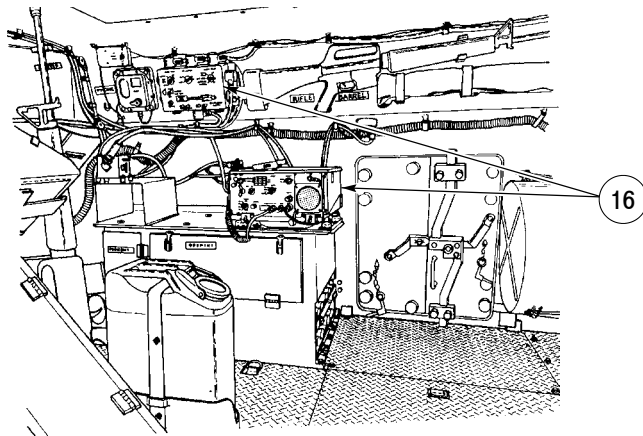

03i005mb

END OF TASK

STARTING MAIN ENGINE

0012 00

THIS WORK PACKAGE COVERS:

Starting Main Engine

INITIAL SETUP:

References

- WP 0105 00
- WP 0053 00
- WP 0074 00
- WP 0075 00

References - Continued

- WP 0011 00
- WP 0077 00
- WP 0090 00
- WP 0013 00

1. Before starting main engine and driving the vehicle, perform all BEFORE operation procedures in PMCS Table 1 (WP 0105 00).

NOTE

The main engine can be started normally unless battery voltage is too low to power starter motor. The auxiliary power unit can be started to charge batteries (WP 0053 00). If the auxiliary power unit is nonfunctional, the main engine can be slave started (WP 0074 00) or tow started (WP 0075 00).

2. Prior to starting main engine with any of three starting methods, perform engine prestart procedures (WP 0011 00).

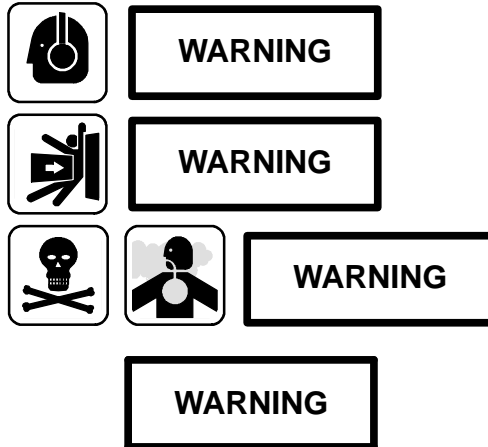

Do not leave the operator's seat while the engine is running. Failure to comply may result in accidental movement of vehicle causing injury or DEATH to personnel.

NOTE

When MASTER switch is on, warning indicators and horn will be on when engine is started until oil pressure builds up.

For cold weather start, refer to WP 0077 00.

3. Make sure steering wheel (1) is centered and locked.
4. Turn MASTER switch (2) ON.

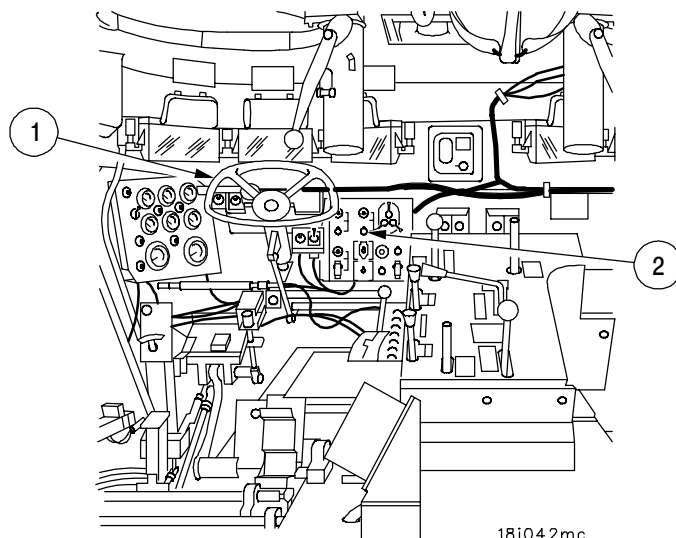

WARNING

If LOW BRAKE PRESSURE indicator comes on and stays on, do not operate vehicle. Potential loss of brakes could cause injury or death to personnel. Notify Unit Maintenance.

5. Move FUEL TANK toggle switch (3) to FRONT then REAR positions and check fuel tank levels indicated on FUEL GAUGE (4) .
6. Move engine PREHEAT switch (5) to PURGE for 10 seconds and then to OFF position. This will remove air from the fuel lines if the vehicle has been sitting for a long time or maintenance has been performed on fuel system.

CAUTION

Do not hold START button in continuously for longer than 15 seconds. Starter motor will overheat. Failure to comply may result in damage to equipment.

7. Depress accelerator pedal (6) to its full travel. Push and hold START button (7) until engine runs. Release START button and accelerator pedal when engine starts. If engine cranks, but fails to start, turn OFF MASTER switch and wait three to five minutes. Repeat starting procedures. If engine does not start after sixth try, troubleshoot (WP 0090 00).

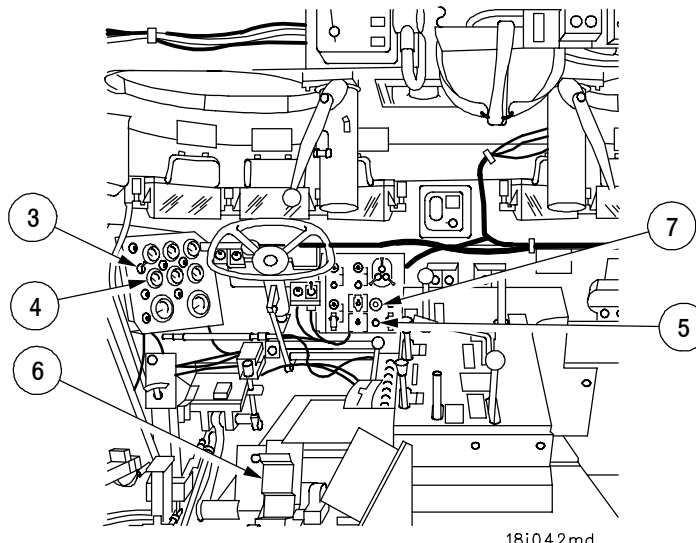

18i042md

CAUTION

If SYSTEM WARNING indicator does not go out in about 20 seconds after engine starts, stop engine and notify unit maintenance. Failure to comply may result in damage to equipment.

8. If battery charge is too low to start engine, start Auxiliary Power Unit (WP 0053 00) and charge batteries for 20 minutes.
9. Adjust hand throttle (8) for an idle speed of 1000 to 1200 rpm and let engine warm up for three minutes.
10. If engine runs roughly during warm-up, hold engine PREHEAT toggle switch (5) to PREHEAT until smooth engine operation returns. Release PREHEAT toggle switch (5) after engine runs smoothly.

NOTE

During long standstill periods with engine running, hold engine speed at 1000 to 1200 rpm to keep it running smoothly.

11. After 3 minutes set hand throttle (8) for a low idle of 825 to 875 rpm.
12. Check engine for normal operation (WP 0013 00).

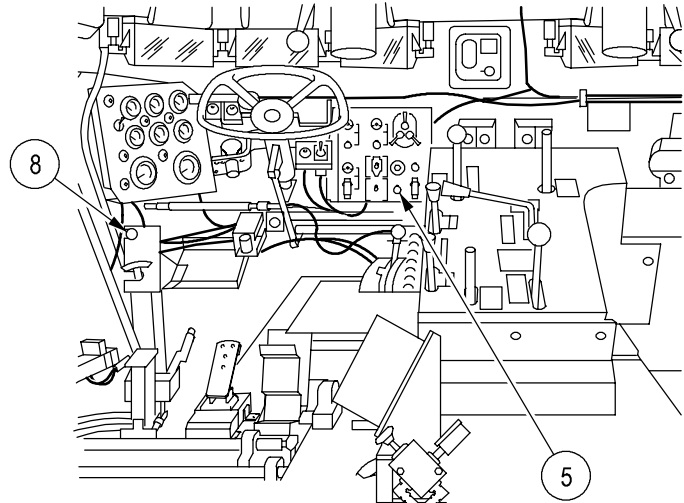
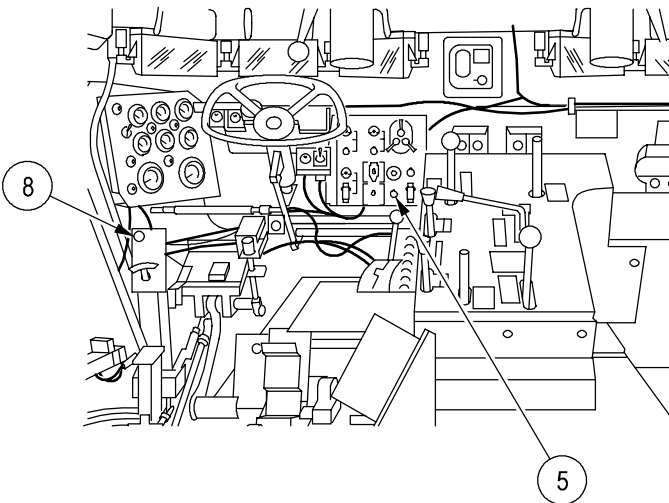

**NEW CONFIGURATION
WITH BRAKE MODULATION AND
ENHANCED PARKING BRAKE**

18i042mf

END OF TASK

NORMAL ENGINE OPERATION**0013 00****THIS WORK PACKAGE COVERS:**

Normal Engine Operation

INITIAL SETUP:**References**

WP 0085 00

Once main engine is started, check following gauges for normal engine operating ranges. If SYSTEM WARNING indicator lights and warning horn sounds while operating vehicle, check following gauges and indicators for normal operation and then shut down engine.

CAUTION

If any of the following gauges or indicators indicate conditions out of the normal ranges stated below, stop main engine and troubleshoot (WP 0085 00). Failure to comply may result in equipment damage.

1. All warning indicators should go out after engine has run for about 20 seconds.
2. Engine oil pressure (1): 40 to 70 psi (276 kPa to 620 kPa) at 2400 rpm, 10 to 15 psi (69 kPa to 103 kPa) at low idle (825 to 875 rpm).
3. Engine oil temperature (2): 160° to 220° F (71° to 104°C) when warmed up.
4. Transmission oil pressure (3): 15 to 19 psi (103 kPa to 131 kPa) at 2400 rpm when cold, a minimum of 10 psi (69 kPa) at 2400 rpm when warm, and a minimum of 5 psi (34 kPa) at low idle.
5. Transmission oil temperature (4): 160° to 260° F (71° to 140° C) when warmed up.
6. Generator voltage output (5): needle should point to middle of green area.
7. Brake pressure (6): needle should indicate between 750 and 950 psi (3275 kPa and 6550 kPa) (old configuration) or between 1100 and 1300 psi (7584 kPa and 8963 kPa) (new configuration with brake modulation and enhanced parking brake).

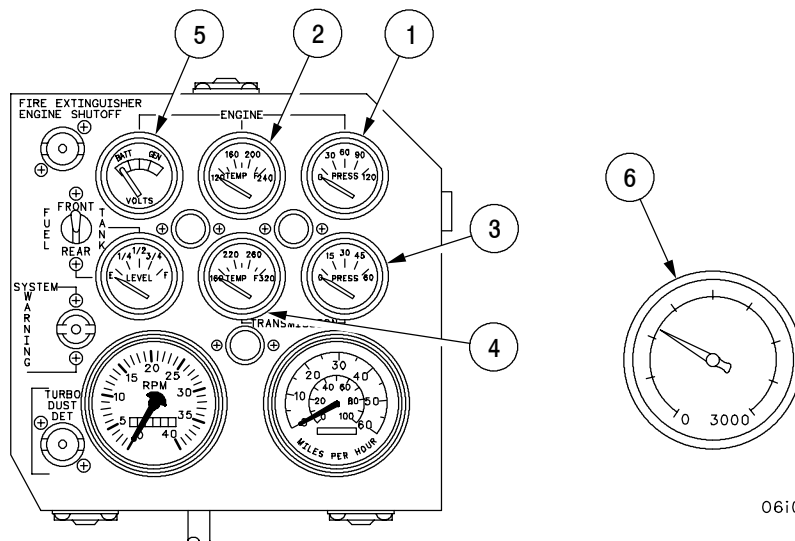

06i014.mc

NORMAL ENGINE OPERATION - CONTINUED

0013 00

8. The SYSTEM WARNING indicator (7) will light and warning horn will sound if any of the following conditions are encountered:

Engine oil temperature is above 240° F (115° C).

Engine oil pressure is below 13 psi (90 kPa) during start or less than 9 psi (62 kPa) when running.

Transmission oil temperature is above 260° F (127° C).

Electromagnetic clutch oil temperature is above 285°F (141° C).

Brake system pressure drops below 475 psi (3274 kPa) (old configuration and new configuration) or 550 psi (3792 kPa) (new configuration with brake modulation and new configuration with brake modulation and enhanced parking brake).

9. There should be no unusual noises from engine.

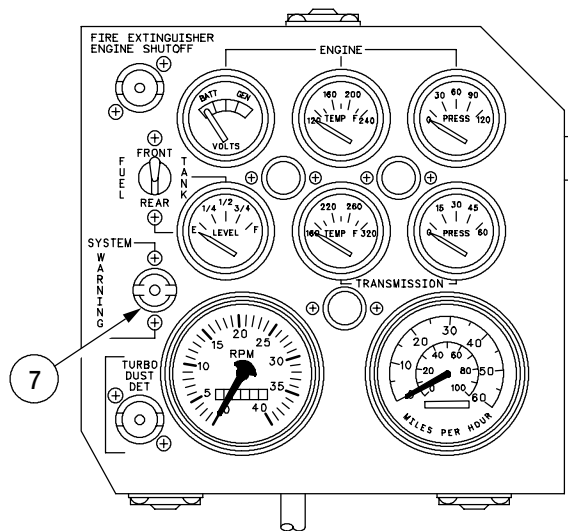

06i014.md

END OF TASK

TRANSMISSION SHIFT SELECTION

0014 00

THIS WORK PACKAGE COVERS:

Park (P) position, Neutral (N) position, Reverse (R) position, First Gear (1ST), Second Gear (2ND), Third Gear (3RD)

The transmission is controlled by the transmission shift selector. The transmission shift selector has six positions: park (P), neutral (N), reverse (R), first gear (1st), second gear (2nd) and third gear (3rd). The transmission does not up shift or down shift automatically. The operator must select the proper gear range as speed increases and decreases. Use transmission positions as follows:

PARK (P)

Use P when:

1. Starting main engine
2. Locking steering
3. Vehicle is parked
4. Vehicle is stationary and using boom and winches
5. Vehicle is halted for long periods with engine running
6. Personnel or equipment is nearby

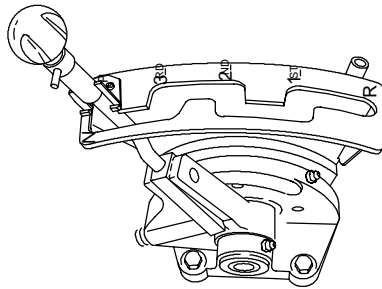

ENHANCED PARKING

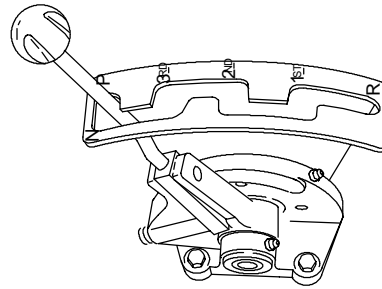

07i016mb

NEUTRAL (N)

Use N when:

1. Vehicle is halted for short period (use foot brake to keep vehicle from moving)
2. Doing neutral steer
3. When vehicle is being towed

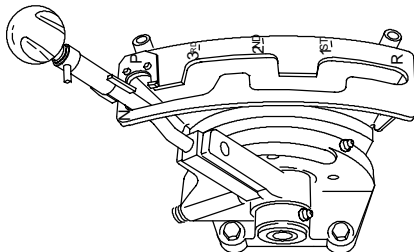

ENHANCED PARKING

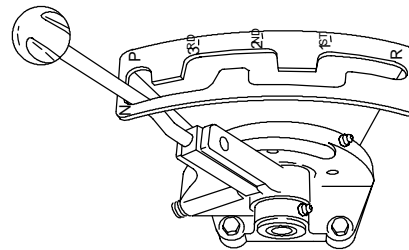

07i016mc

TRANSMISSION SHIFT SELECTION - CONTINUED**0014 00****REVERSE (R)****WARNING**

Vehicle steers in opposite direction when transmission is in reverse. Turn wheel right, vehicle moves left. Turn wheel left, vehicle moves right. Be sure that steering wheel is positioned correctly before moving vehicle. Failure to comply may result in equipment damage or injury to personnel.

Do not shift into reverse when vehicle is moving forward. Personnel could be thrown from seats and injured and/or equipment could be damaged.

Use R when backing up.

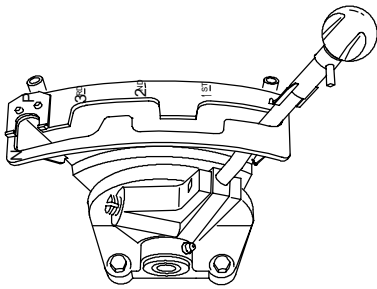

ENHANCED PARKING

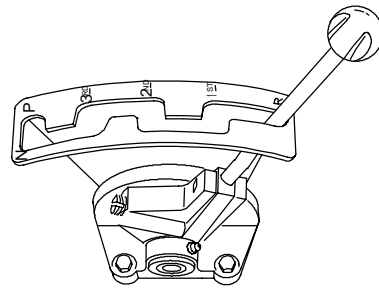

07i016md

FIRST GEAR (1ST)

Use 1st when:

1. Going up or down steep slopes
2. In soft, muddy or very rough terrain
3. Crossing a ditch, shell hole or other obstacle
4. Pivoting
5. Towing another vehicle over rough terrain
6. Fording

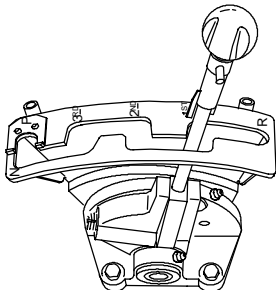

ENHANCED PARKING

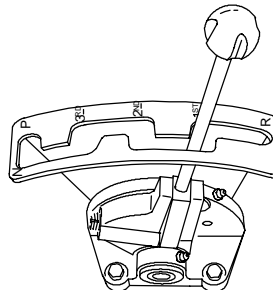

07i016me

TRANSMISSION SHIFT SELECTION - CONTINUED**0014 00****SECOND GEAR (2ND)****NOTE**

Shift from 1st to 2nd gear when going over 5 mph. Shift from 2nd to 1st gear when going under 5 mph.

CAUTION

Do not downshift from 2nd to 1st gear above 5 mph. Failure to comply may result in damage to the transmission.

Use 2nd when:

1. Starting vehicle in motion (normally)
2. Going up or down slopes
3. Operating under heavy load
4. Operating vehicle in deep or loose sand

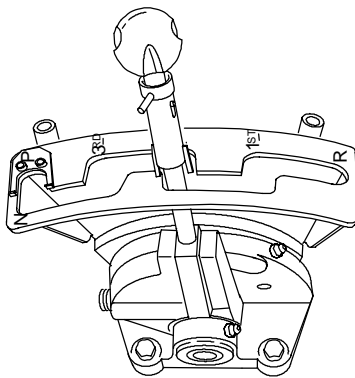

ENHANCED PARKING

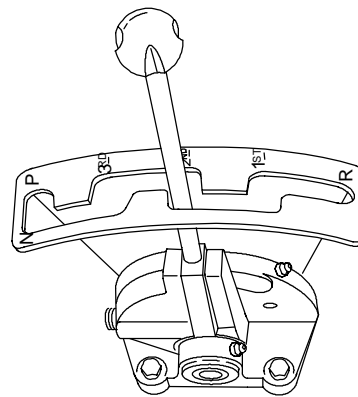

071016mf

TRANSMISSION SHIFT SELECTION - CONTINUED**0014 00****THIRD GEAR (3RD)****CAUTION**

Do not downshift from 3rd to 2nd gear above 12 mph. Failure to comply may result in damage to the transmission.

NOTE

Shift from 2nd to 3rd gear when going over 12 mph. Shift from 3rd to 2nd gear when going under 12 mph.

Use 3rd when driving under normal conditions on hard surfaced road. Top speed is 30 mph (50 kmph).

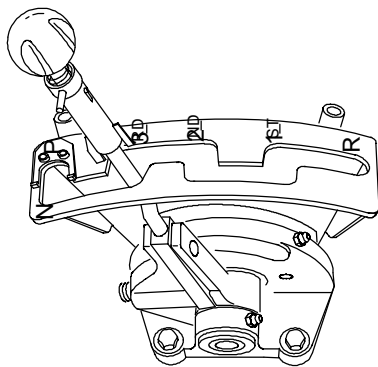

ENHANCED PARKING

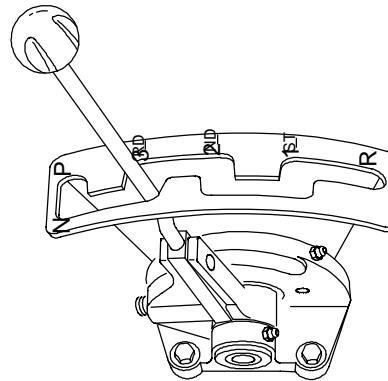

07i016mg

END OF TASK

STEERING INSTRUCTIONS

0015 00

THIS WORK PACKAGE COVERS:

Steering – Forward, Steering – Reverse, Steering – Neutral

WARNING

Do not jerk vehicle around into a hard turn. Failure to comply may result in personnel being thrown from seat causing injury to personnel or damage to equipment.

Steer the vehicle using steering wheel. Be careful when steering the vehicle, it doesn't handle like a car. Instead of making one continuous turn, make series of smaller turns that will result in same turning radius.

STEERING INSTRUCTIONS – CONTINUED

0015 00

STEERING - FORWARD

1. Select 2nd or 3rd gear for wide turns.
2. Select 1st gear for sharper turns.
3. While vehicle is traveling forward, turn steering wheel left or right in a series of small turns until vehicle is pointed in desired direction.

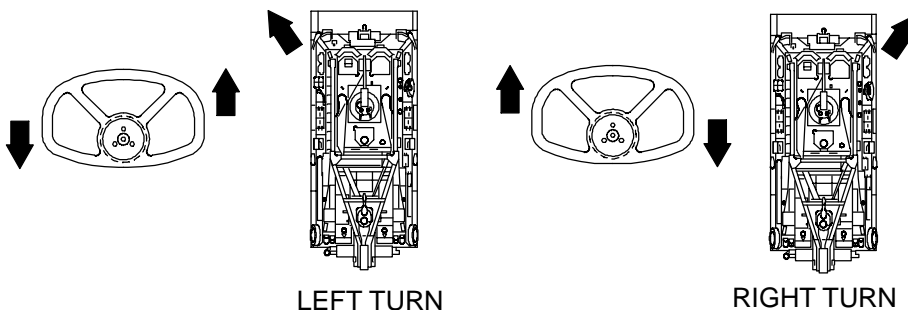

LEFT TURN

RIGHT TURN

14i030m

STEERING - REVERSE

WARNING

Use two ground guides when backing vehicle. Inadequate guidance during backing operation may result in accidental impact causing injury or DEATH to personnel or equipment damage.

NOTE

While vehicle is driven in reverse, the vehicle steers in the opposite direction from normal forward steering.

1. Select R on transmission shift selector.
2. While vehicle is traveling in reverse, turn steering wheel left to make rear of the vehicle go right; or turn steering wheel right, to make rear of vehicle go left, in a series of small turns until vehicle is pointed in desired direction.

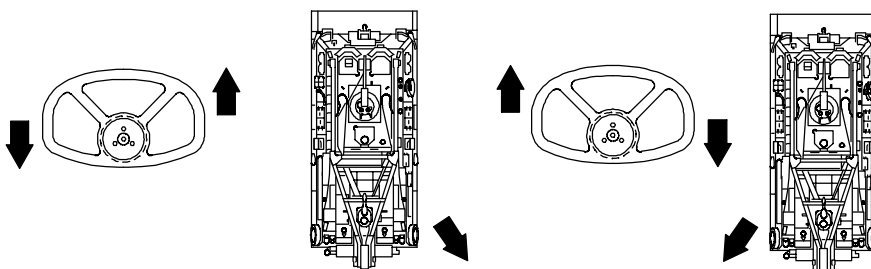

RIGHT TURN

LEFT TURN

14i030ma

STEERING INSTRUCTIONS - CONTINUED

0015 00**NEUTRAL STEERING****WARNING**

Vehicle must be at a complete stop prior to shifting transmission to neutral. Failure to comply may result in serious injury or DEATH to personnel and damage to equipment.

CAUTION

Sudden turns on smooth level ground can throw track. Make slow pivot turns. Failure to comply may result in equipment damage.

1. Stop vehicle and shift transmission into neutral (N).
2. Turn steering wheel full turn to desired direction.
3. Accelerate engine slowly until vehicle points in desired direction.

END OF TASK

DRIVING THE VEHICLE

0016 00**THIS WORK PACKAGE COVERS:**

Normal, Driving over Rough, Soft or Hilly Terrain, Emergency Procedures for Driving Down Steep Grades Forward with Transmission in Reverse, Emergency Procedures for Driving Down Steep Grades Backward with Transmission in 1st Gear, Driving Up Steep Grades, Crossing a Ditch, Shell Hole or Trench, Going Over an Obstacle, Driving in Sand, Dirt or Rocks

INITIAL SETUP:**References**WP 0105 00

WARNING

If the engine throttle sticks or fails, immediately shut down engine using the fuel shut-off control, place transmission in NEUTRAL, and apply brakes to bring vehicle to a stop. Failure to comply may result in personnel injury, DEATH, and equipment damage due to loss of vehicle control.

Do not use hand throttle control in place of accelerator for speed control except in an emergency. Failure to comply may result in injury or DEATH to personnel.

Secure boom, spade, hatches, doors, and all other equipment before moving out. Failure to comply may result in injury or DEATH to personnel from shifting equipment or damage to equipment.

DRIVING THE VEHICLE - CONTINUED**0016 00****NORMAL****CAUTION**

Do not use brakes if vehicle throws a track while driving. Let off accelerator and coast to a stop. Failure to comply may result in damage to equipment.

1. Push hand throttle all the way in so engine is at low idle (825 to 875 rpm).

WARNING

Make sure brakes are fully applied and locked for parking when holding vehicle on a longitudinal grade of up to 60%. If parking brake fails to hold, do not attempt to park vehicle on slope. Place vehicle on level ground and block track before leaving vehicle. Failure to comply may result in personnel injury/death due to impact and/or vehicle/object damage due to collision

2. Hold brake pedal down and shift to 2nd gear (use 1st gear if towing a disabled vehicle).
3. Release brake pedal and accelerate to desired speed while shifting transmission at 5 mph (1st to 2nd gear) and 12 mph (2nd to 3rd gear).

NOTE

If starting on an uphill grade, apply power with accelerator before releasing brake. This will avoid rolling backward.

4. Steer vehicle in desired direction using steering wheel.
5. While driving, check your gauge panel frequently (item 15, Table 2, WP 0105 00).
6. Do the DURING OPERATION PMCS tasks.

DRIVING OVER ROUGH, SOFT, OR HILLY TERRAIN**WARNING**

Do not allow vehicle to get out of control. Be careful, know the vehicle and how it handles. Failure to comply may result in injury or DEATH to personnel and damage to equipment.

1. Ensure hatches are in the locked position and all equipment is properly stowed.
2. Drive slowly over rough terrain using 1st gear.
3. Make wide slow turns in soft terrain using 1st gear to keep from throwing a track.

CAUTION

Use the following procedures only in an EMERGENCY situation. The use of engine and transmission as a brake may result in damage to the equipment.

EMERGENCY PROCEDURES FOR DRIVING DOWN STEEP GRADES FORWARD WITH TRANSMISSION IN REVERSE**CAUTION**

Do not use transmission as a braking source for a long period of time. Transmission will overheat which may result in damage to equipment.

Do not use brakes too long. Release brakes occasionally to cool them and keep them from burning out. Failure to comply may result in degraded braking capability or equipment damage.

1. Stop vehicle on hill and shift transmission selector into R gear before starting downhill.
2. Start vehicle down hill while applying brakes now and then to help slow vehicle.

EMERGENCY PROCEDURES FOR DRIVING DOWN STEEP GRADES BACKWARD WITH TRANSMISSION IN 1ST GEAR

1. Close LEFT and RIGHT TANK FUEL CONTROL VALVES to prevent fuel from draining into the rear tanks and starving the fuel pump.

CAUTION

Do not use transmission as a braking source for a long period of time. Transmission will overheat which may result in damage to equipment.

Do not use brakes too long. Release brakes occasionally to cool them and keep them from burning out. Failure to comply may result in degraded braking capability or equipment damage.

2. Stop vehicle and shift transmission selector into 1st gear when rear of vehicle is headed downhill.
3. Continue downhill while applying brakes now and then to help slow vehicle. This uses the engine as a brake and prevents the brakes from burning out.

DRIVING UP STEEP GRADES

1. Close LEFT and RIGHT TANK FUEL CONTROL VALVES to prevent fuel from draining into the rear tanks and starving the fuel pump.
2. Slow vehicle to 5 mph or slower and shift transmission selector into 1st gear.
3. As soon as vehicle starts to climb, depress accelerator for power needed to climb grade.

DRIVING THE VEHICLE - CONTINUED

0016 00**CROSSING A DITCH, SHELL HOLE, OR TRENCH****WARNING**

Approach an obstruction or obstacle head-on when possible. Warn crew members to brace themselves. Secure hatches and doors. Failure to comply may result in injury or DEATH to personnel.

1. Slow vehicle to 5 mph or slower and shift transmission selector to 1st gear.
2. As soon as vehicle reaches the bottom and starts to climb, depress the accelerator for power needed to climb out of the ditch.

GOING OVER AN OBSTACLE**WARNING**

Approach an obstruction or obstacle head on when possible. Warn crew members to brace themselves. Secure hatches and doors. Failure to comply may result in injury or DEATH to personnel.

1. When approaching an obstacle (42 in. (107cm) maximum height), slow vehicle to 5 mph or slower and shift transmission selector to 1st gear.
2. Apply full power when starting over the obstacle, release the accelerator pedal on reaching the crest and permit vehicle to settle over it. Balance vehicle forward of crest so it begins to move down.
3. When front of tracks touch ground, accelerate and move on.

DRIVING IN SAND, DIRT, OR ROCKS**CAUTION**

Do not make sharp turns in 1st gear. Sand, dirt, or rocks may build up between track and sprocket causing a track to be thrown. Failure to comply may result in damage to equipment.

1. Make wide turns in second or third gear when driving in sand, dirt, or rock to keep from throwing a track.
2. If using 1st gear, make gradual turns.

END OF TASK

STOP THE VEHICLE

0017 00

THIS WORK PACKAGE COVERS:

Stop the Vehicle

1. Release accelerator pedal (1) and slowly depress brake pedal (2).

WARNING

Make sure brakes are fully applied and locked for parking when holding vehicle on a longitudinal grade of up to 60%. If parking brake fails to hold, do not attempt to park vehicle on slope. Place vehicle on level ground and block track before leaving vehicle. Failure to comply may result in personnel injury/death due to impact and/or vehicle/object damage due to collision.

NOTE

For the enhanced parking, pull up on T-handle (2A) in order to shift selector (3) to P.

2. When vehicle comes to a complete stop, lock brakes by depressing brake pedal (2) and shift transmission selector (3) to P.

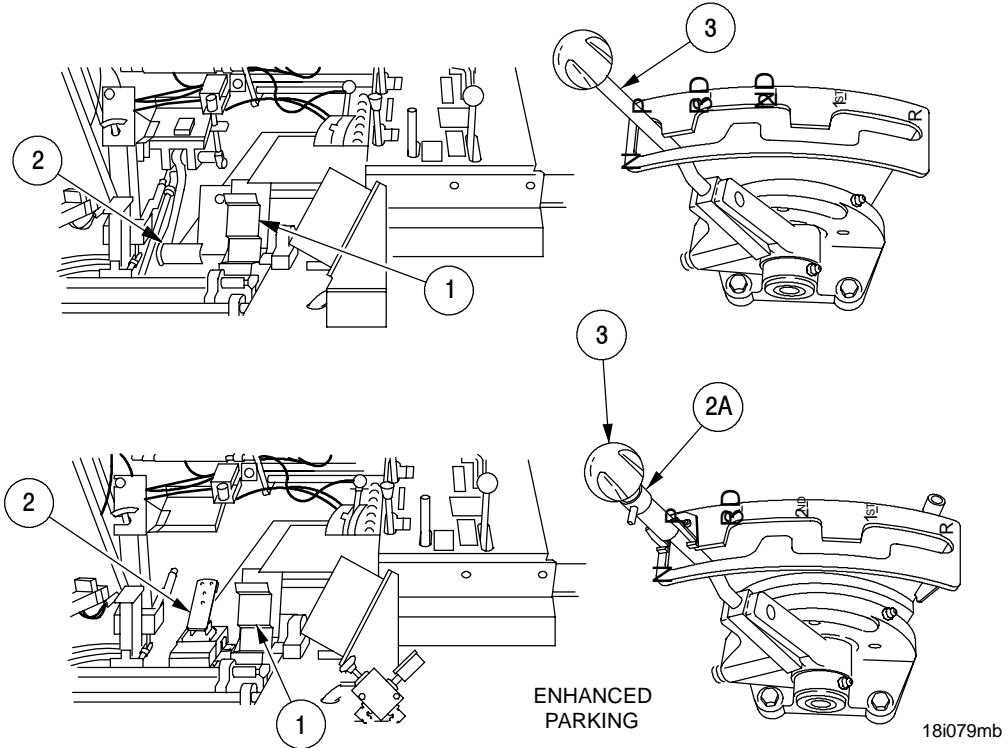

END OF TASK

BACKING THE VEHICLE

0018 00

THIS WORK PACKAGE COVERS:

Backing the Vehicle

INITIAL SETUP:

Personnel Required

Three

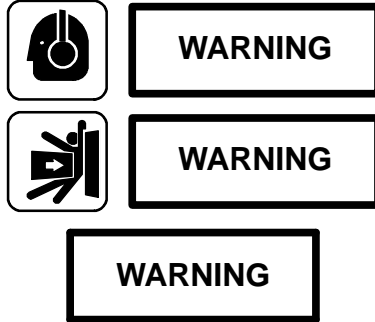

When backing the vehicle, two personnel must guide driver. Both guides must stand to left a safe distance from vehicle. Left front guide must be visible to driver. Failure to comply may result in injury to personnel or damage to equipment.

NOTE

When backing vehicle, steering works in opposite direction from normal forward steering.

1. To prepare for backing vehicle, driver (D) is seated at controls, looking to left of vehicle. Mechanic (M) stands to left of vehicle, visible to both driver and commander (C). The commander stands to left and rear of vehicle, visible to mechanic.
2. Commander signals mechanic on direction and distance for safe backup. Mechanic relays signals to driver.

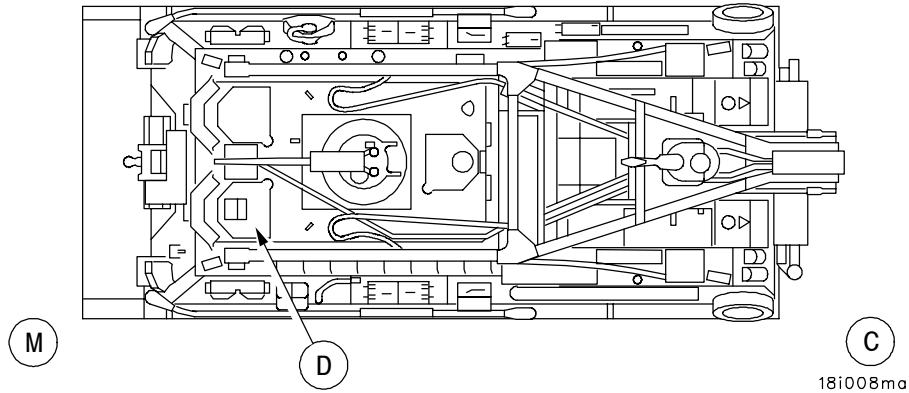

18i008ma

END OF TASK

SHUTDOWN MAIN ENGINE

0019 00

THIS WORK PACKAGE COVERS:

Shutdown Main Engine

INITIAL SETUP:

References

WP 0017 00

1. Stop the vehicle, set brakes (WP 0017 00) and shift transmission selector (1) to P (WP 0017 00).
2. Set hand throttle (2) for engine idle speed of 1,000 to 1,200 rpm to cool engine.
3. After three to five minutes set hand throttle (2) for engine idle speed of 825 to 875 rpm.
4. Hold ENGINE FUEL SHUTOFF switch (3) down until the engine stops.

NOTE

If engine fails to shut off, pull the manual fuel shutoff handle until engine stops. Notify unit maintenance.

5. Turn off all radios and electrical switches.
6. Turn MASTER switch (4) OFF.

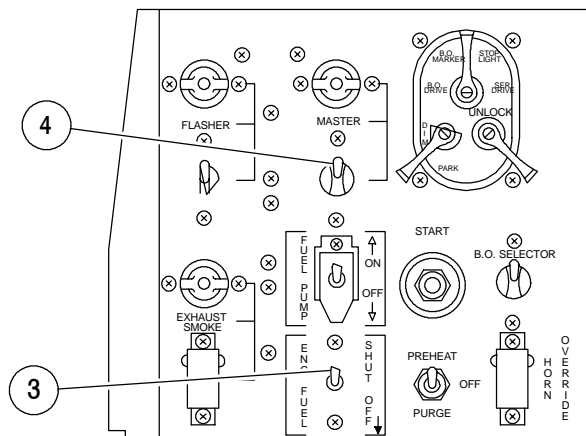
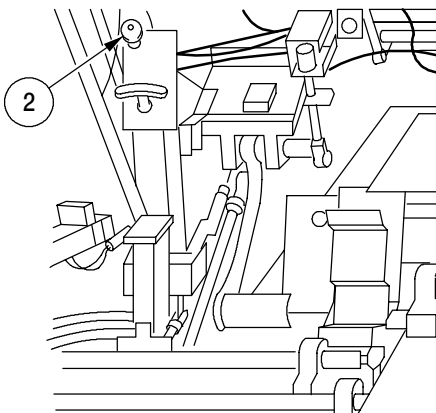
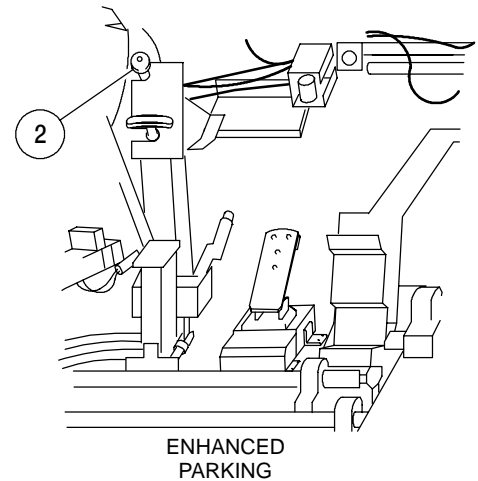
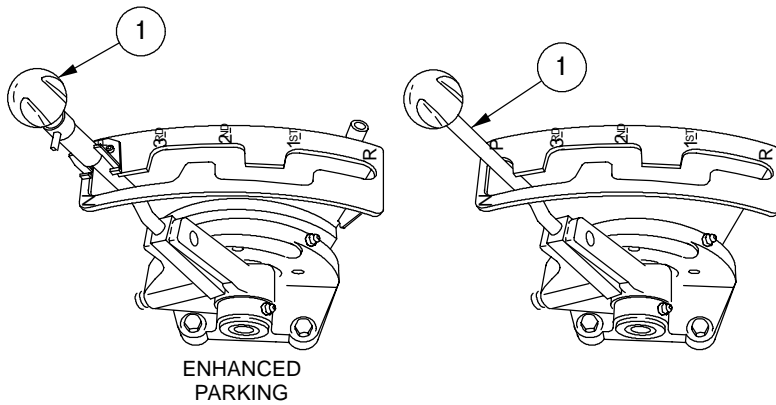

18i229ma

END OF TASK

OPERATE FUEL CONTROL VALVES

0020 00

THIS WORK PACKAGE COVERS:

Operation, Draining Tanks

Four fuel control valves are located on rear crew compartment wall. They are used to open or close fuel tank and drain valves.

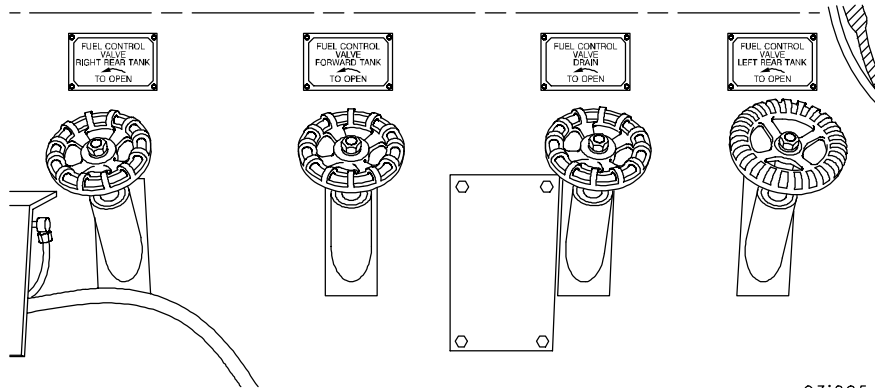

031005mc

OPERATION

Fuel valve positions

	Right tank (a)	Forward tank (b)	Drain (c)	Left tank (d)
Normal operation	Open	Closed	Closed	Open
Refuel - Defuel	Open	Closed	Closed	Open
APU operation	Open	Closed	Closed	Open

NOTE

If rear tanks are too low for APU operation, OPEN forward tank valve (b). CLOSE valve when you are finished.

DRAINING TANKS

Forward	Closed	Open	Open	Closed
Forward and right	Open	Open	Open	Closed
Forward and left	Closed	Open	Open	Open

END OF TASK

OPERATE DOME LIGHT**0021 00****THIS WORK PACKAGE COVERS:**

Operate Dome Light

1. Turn MASTER switch ON.
2. For blue light, turn switch lever (1) fully clockwise.
3. For white light, press safety latch (2) and turn switch lever (1) counterclockwise past stop.
4. To turn off both lights, position switch lever (1) in center.

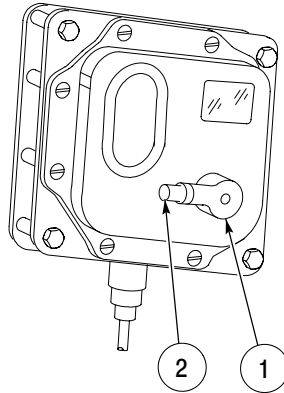

06i025m

END OF TASK

OPERATE REAR SERVICE LIGHTS**0022 00****THIS WORK PACKAGE COVERS:**

Operate Rear Service Lights

1. Turn MASTER switch ON.
2. Place SERVICE toggle switch (1) in ON position.

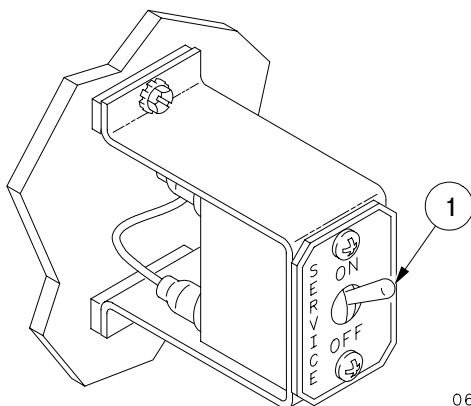

06i120mb

END OF TASK

OPERATE LIGHT SWITCH ASSEMBLY**0023 00****THIS WORK PACKAGE COVERS:**

Operate Light Switch Assembly

The following diagram shows which lights are turned on by different positions of light switch assembly.

1. Turn MASTER switch ON.
2. Push up unlock lever (1) to release selector switch (2). Release unlock lever after selector switch is properly positioned.
3. Push up on instrument panel light switch (3) to turn on and vary brightness of instrument panel lamps. Push down on instrument panel light switch (3) to select the park lights.
4. Use dimmer foot switch to select between high and low beams.

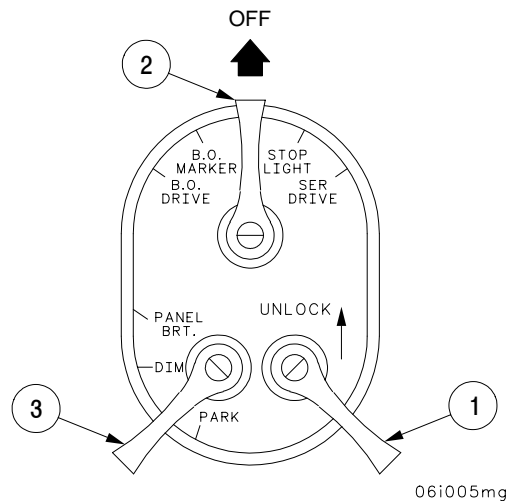

NOTE:
FOR B.O. DRIVE, STOPLIGHT,
AND SERVICE DRIVE, USE
UNLOCK LEVER.

NOTE

Refer to the following diagram for light switch position and corresponding light operation.

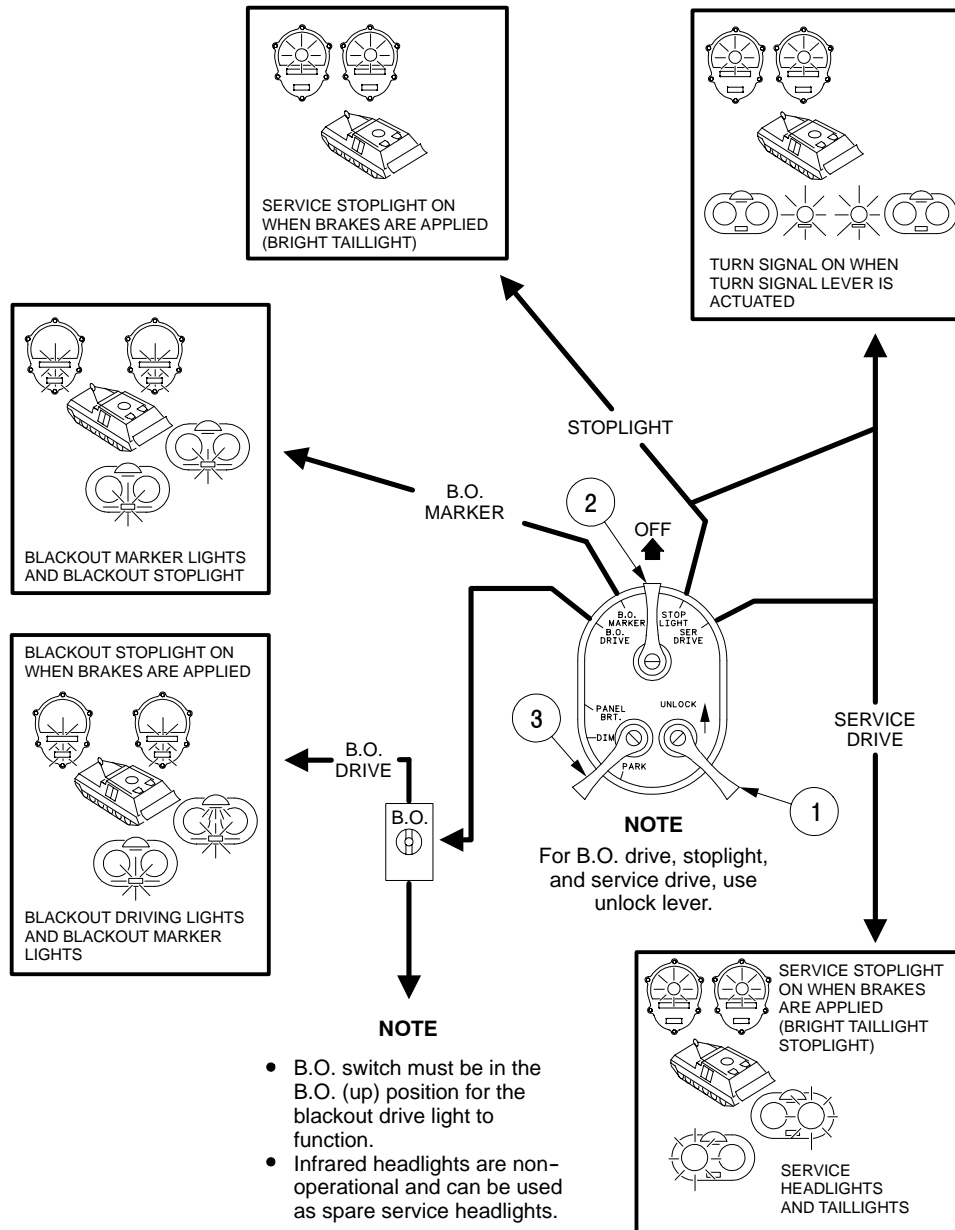

06i156m

END OF TASK

OPERATE HULL AND CREW COMPARTMENT DOORS**0024 00****THIS WORK PACKAGE COVERS:**

Operate Hull and Crew Compartment Doors

1. Lift handle (1), open door, and lock in open position with handle (2).
2. Insert pin (3) in handle (2).
3. Lift handle (4), open door, and lock in open position with handle (5).
4. Insert pin (6) in handle (5).

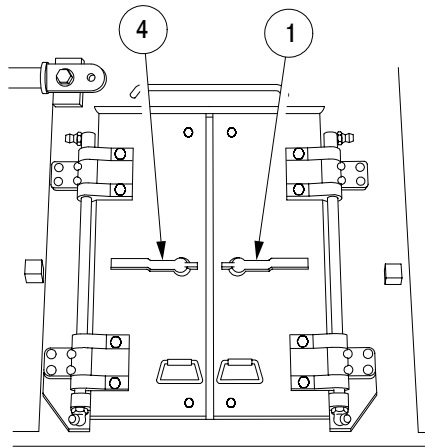

OUTSIDE VIEW

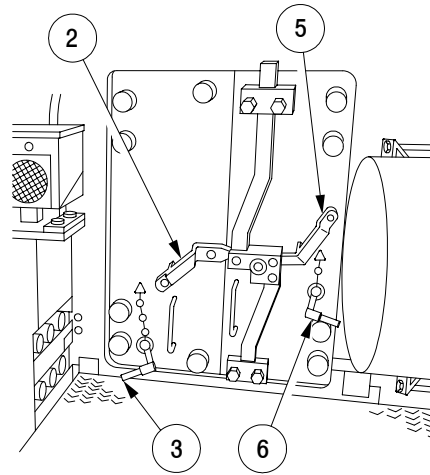

INSIDE VIEW

18i016ma

END OF TASK

OPERATE COMMANDER'S CUPOLA**0025 00****THIS WORK PACKAGE COVERS:**

Open Cupola Hatch, Close Cupola Hatch, Rotate Cupola

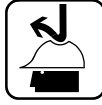
**WARNING****OPEN CUPOLA HATCH**

1. Pull out and up on hatch handle (1).
2. Open cupola hatch until safety catch latches in full open position.

CLOSE CUPOLA HATCH

1. Unlatch safety catch and close cupola hatch.
2. Lock cupola hatch by pushing in and down on hatch handle (1).

ROTATE CUPOLA

1. Turn rotation control handle (2) counterclockwise to unlock and allow cupola to rotate freely.
2. Turn rotation control handle (2) clockwise to lock cupola in place.

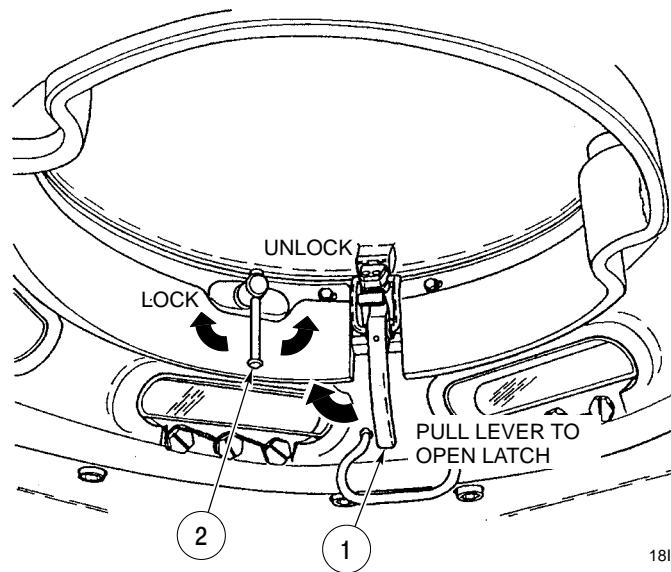

18I251M

END OF TASK

OPERATE OPERATOR'S, MECHANIC'S AND PERSONNEL HATCH**0026 00****THIS WORK PACKAGE COVERS:**

Open Hatch, Close Hatch

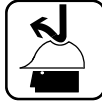
**WARNING****NOTE**

Some vehicles are not equipped with personnel hatches.

OPEN HATCH

1. Push handle (1) forward to unlatch hatch cover.
2. While holding handle (1) forward, turn handle to open hatch cover.
3. Check outside of hatch cover to be sure it is fully open.
4. Lower handle (1) and latch with locking tang (2).

CLOSE HATCH

1. Unlatch locking tang (2) and push handle (1).
2. Turn handle (1) to close hatch cover.
3. Lower handle (1) to seat hatch cover over hatch opening.

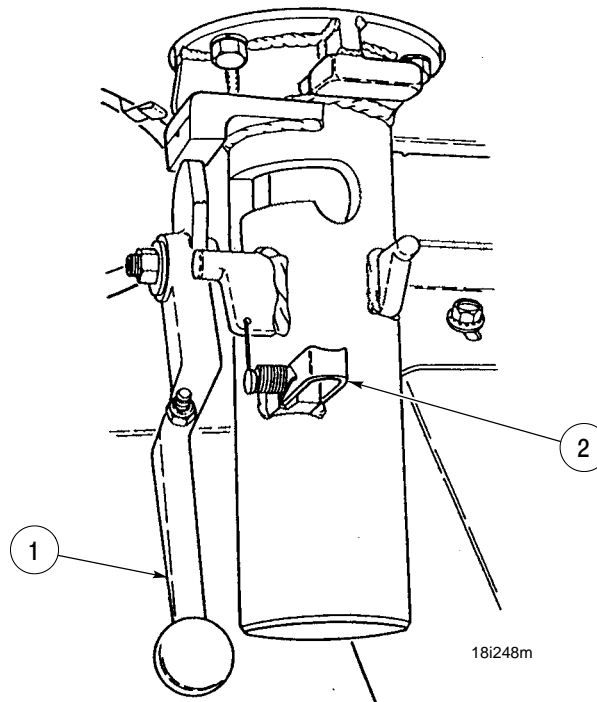
**END OF TASK**

OPERATE STORAGE COMPARTMENT DOOR, LEFT SIDE HULL**0027 00****THIS WORK PACKAGE COVERS:**

Operate Storage Compartment Door

1. Remove padlock, if present.
2. Turn handle (1) clockwise one quarter turn.
3. Open door.

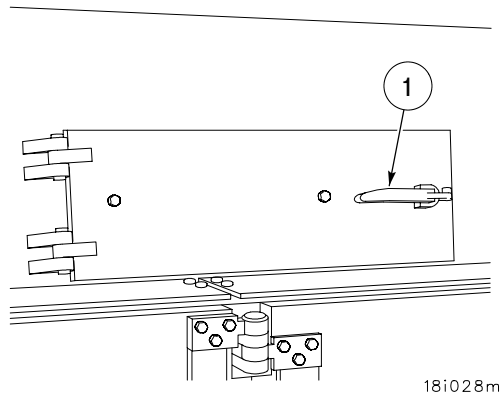
**END OF TASK**

OPERATE STORAGE COMPARTMENT DOOR, RIGHT SIDE HULL**0028 00****THIS WORK PACKAGE COVERS:**

Operate Storage Compartment Door

1. Remove padlock, if present.
2. Turn handle (1) clockwise one quarter turn.
3. Open door.

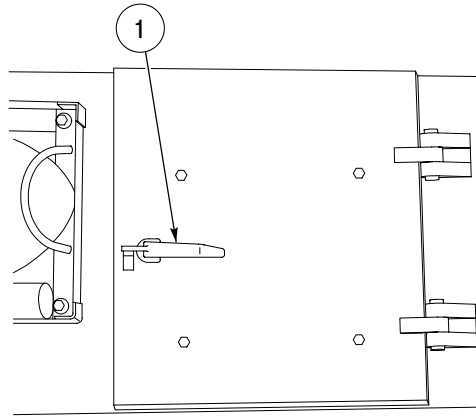

18i028ma

END OF TASK**0028 00-1/2 blank**

OPERATE HOIST WINCH CABLE ACCESS DOOR

0029 00**THIS WORK PACKAGE COVERS:**

Removal, Installation

INITIAL SETUP:**Tools and Special Tools**

Adjustable wrench (item 40, Table 2, WP 0133 00)

ReferencesWP 0133 00

OPEN HOIST WINCH CABLE HATCH

1. Remove padlock if present.
2. Loosen nuts on two latch assemblies (1) and remove latch assemblies from hull slots.
3. Open hatch cover (2).

CLOSE HOIST WINCH CABLE HATCH

1. Position hoist winch cable in cable slot (3).
2. Close hatch cover (2).
3. Hook two latch assemblies (1) into hull slots and secure nuts.

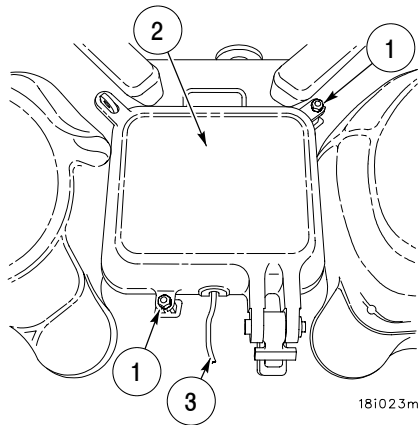
**END OF TASK**

OPERATE APU COMPARTMENT DOOR**0030 00****THIS WORK PACKAGE COVERS:**

Operate APU Compartment Door

1. Remove padlock, if present.
2. Remove headed straight pin (1) from door latch (2).
3. Turn handle (3) counterclockwise one quarter turn.

WARNING

Secure APU compartment door with door latch. Door may slam shut causing injury to personnel.

4. Open door until door latch (2) engages door. Insert headed straight pin (1) in door latch (2).
5. To close door, remove headed straight pin (1) from door latch (2) and press down on spring loaded door latch (2) to release door.
6. Close and secure door using handle (3). Insert headed straight pin (1) in door latch (2).

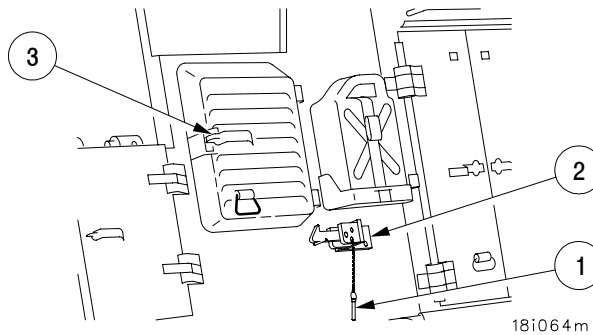
**END OF TASK**

OPERATE ENGINE DECK DOOR**0031 00****THIS WORK PACKAGE COVERS:**

Operate Engine Deck Door

INITIAL SETUP:**Tools and Special Tools**

Adjustable wrench (item 40, Table 2, WP 0133 00)

References

WP 0133 00

1. To open engine deck door, loosen two locking screws (1), turn latch handles (2) clockwise one quarter turn and lift engine deck door using D- ring handle (3).
2. To close engine deck door, lower door, using D-ring handle (3), turn latch handles (2) one quarter turn counterclockwise, and secure two locking screws (1).

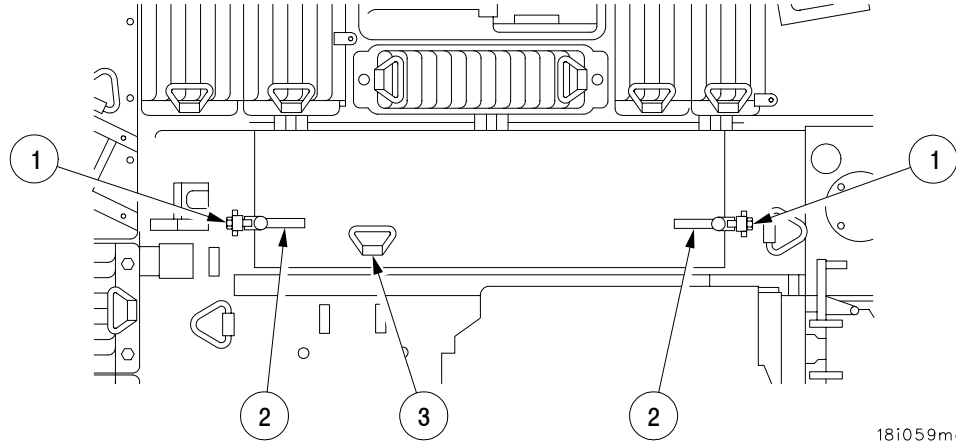

18i059md

END OF TASK

OPERATE REAR ENGINE DECK EXHAUST GRILLE AND EXHAUST DEFLECTOR

0032 00

THIS WORK PACKAGE COVERS:

Open, Close

INITIAL SETUP:

Tools and Special Tools

Adjustable wrench (item 40, Table 2, WP 0133 00)

Personnel Required

Two

References

WP 0133 00

OPEN

1. Loosen two nuts (1) on deflector assembly brackets (2), remove brackets from engine deck studs (3), and lower deflector assembly (4).
2. Loosen nuts on two latch assemblies (5).
3. Swing engine deck exhaust grille doors (8) to side to open.
4. Lift two exhaust deflectors (6) up and secure with latches (7).

CLOSE

1. Unlatch two exhaust deflector latches (7) and lower exhaust deflectors (6).
2. Swing engine deck exhaust grille doors (8) to closed position.
3. Position two latch assemblies (5) and secure nuts.
4. Raise deflector assembly (4) and position deflector assembly brackets (2) on engine deck studs (3) and secure nuts (1).

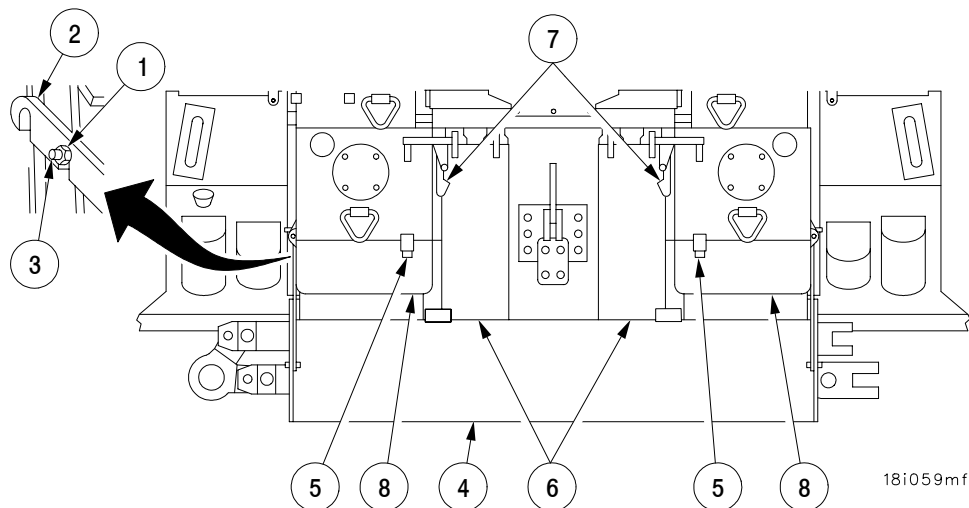

18i059mf

END OF TASK

OPERATE FRONT ENGINE DECK GRILLE

0033 00

THIS WORK PACKAGE COVERS:

Operate Front Engine Deck Grille

INITIAL SETUP:

Tools and Special Tools

Socket wrench set (item 38, Table 2, WP 0133 00)

References

WP 0133 00

1. To open, remove eight screws (1), eight lockwashers (2), eight flat washers (3), grille (4), grille (5), grille (6), and grille (7).
2. To close, install grille (7), grille (6), grille (5), and grille (4), eight flat washers (3), eight lockwashers (2), and eight screws (1).

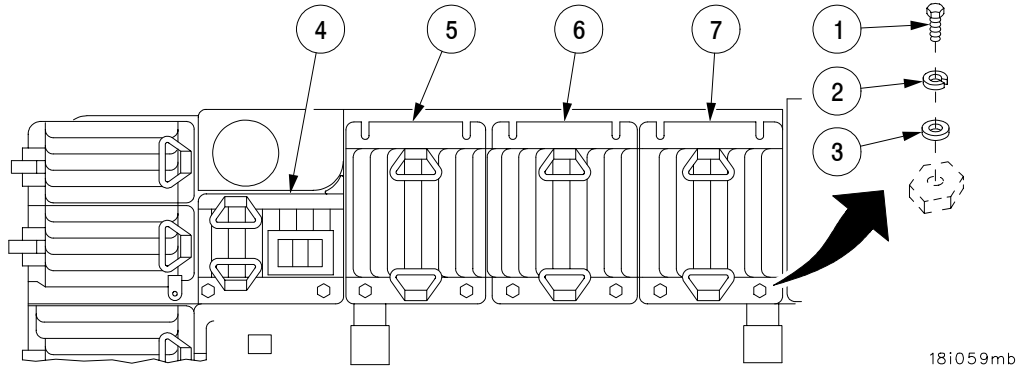

END OF TASK

OPERATE ENGINE DECK SIDE GRILLE**0034 00****THIS WORK PACKAGE COVERS:**

Operate Engine Deck Side Grille

INITIAL SETUP:**Tools and Special Tools**

Socket wrench set (item 38, Table 2, WP 0133 00)

References

WP 0133 00

1. To open, remove four screws (1), four lockwashers (2), four flat washers (3), grille (4), and grille (5).
2. To close, install grille (5), grille (4), four flat washers (3), four lockwashers (2), and four screws (1).

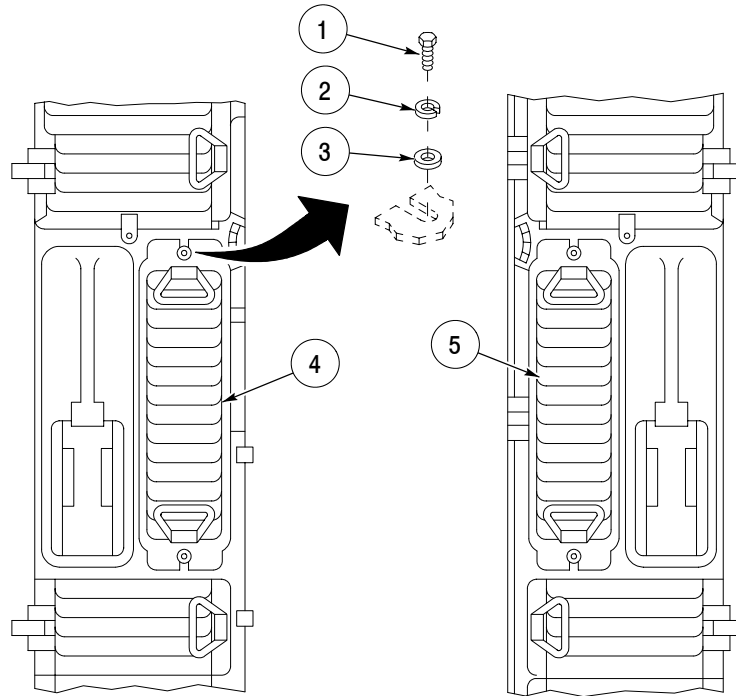

18i059ma

END OF TASK

OPERATE ENGINE DECK ACCESS DOOR**0035 00****THIS WORK PACKAGE COVERS:**

Open, Close

INITIAL SETUP:**Tools and Special Tools**

Socket wrench set (item 38, Table 2, WP 0133 00)

References

WP 0133 00

NOTE

Use the following procedure to open any of the five sets of engine deck access doors.

The boom must be raised to open rear engine deck access doors on either side.

OPEN

1. Loosen screw (1) and move lock (2) from over access door (3).
2. Open access door (3).
3. Open access door (4).

CLOSE

1. Close access door (4).
2. Close access door (3).
3. Position lock (2) over access door (3) and tighten screw (1).

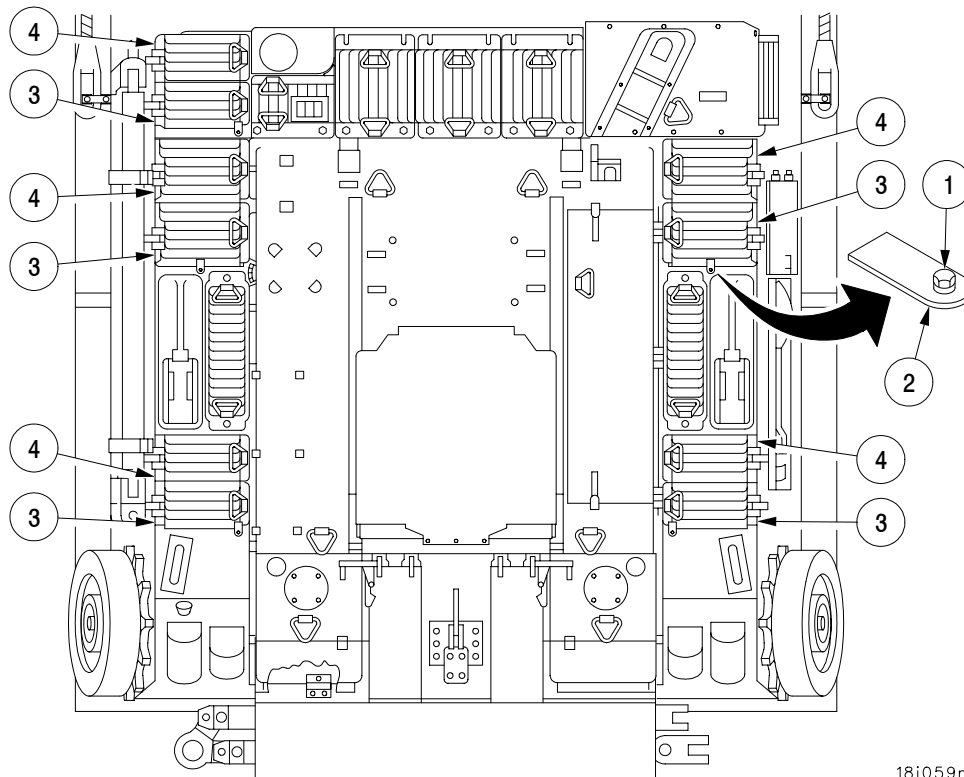

18i059m

END OF TASK

OPERATE SUBFLOOR ACCESS PLATES AND DOORS**0036 00****THIS WORK PACKAGE COVERS:**

Operate Subfloor Access Plates and Doors

INITIAL SETUP:**Tools and Special Tools**

Adjustable wrench (item 40, Table 2, WP 0133 00)

References

WP 0133 00

The floor of the crew compartment contains several doors and plates that must be opened or removed to gain access to components or stowage compartment below them. Access door is lifted to gain access to component below. Remove screws and washers to remove access plates. The diagram below calls out access door or plate and what is beneath it.

1. Main winch access plate (1) - Remove three screws, three flat washers, and access plate to gain access to main winch oil level bayonet gauge and oil fill/drain plug.
2. Right front subfloor stowage compartment (2) - Open door to gain access to BII component and bilge pump.

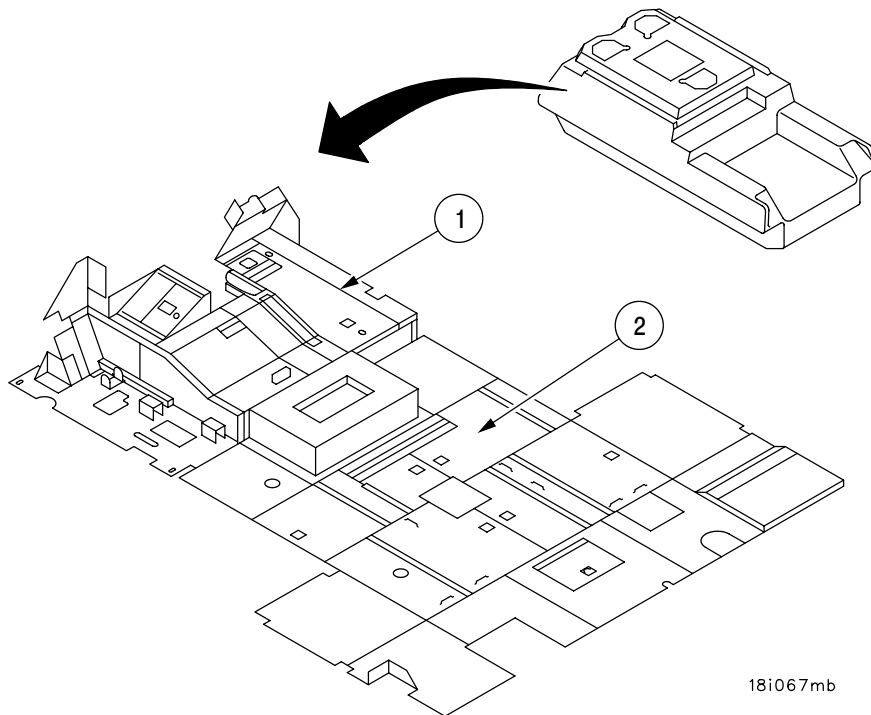

OPERATE SUBFLOOR ACCESS PLATES AND DOORS**0036 00**

3. Hydraulic reservoir access door (3) - Open door to gain access to hydraulic reservoir drain valve.
4. Right rear subfloor stowage compartment (4) - Open door to gain access to BII components.
5. Hydraulic reservoir access plate (5) - Remove two screws, two flat washers, and access plate to gain access to oil level bayonet gauge and filler cap.
6. Electromagnetic clutch access door (6) - Open door to gain access to electromagnetic clutch oil level bayonet gauge and fill/vent cap.
7. Left rear subfloor stowage compartment (7) - Open door to gain access to BII components.
8. Center front subfloor stowage compartment (8) - Open door to gain access to BII components.
9. Left front subfloor stowage compartment (9) - Open door to gain access to BII components and bilge pump.
10. Hoist winch subfloor access plate (10) - Remove four screws and four flat washers. Remove access plate to gain access to hoist winch level/fill plug and vent plug.
11. Service brake linkage access plate (11) - Remove four screws and four flat washers. Remove access plate to gain access to service brake shaft lubrication fittings.

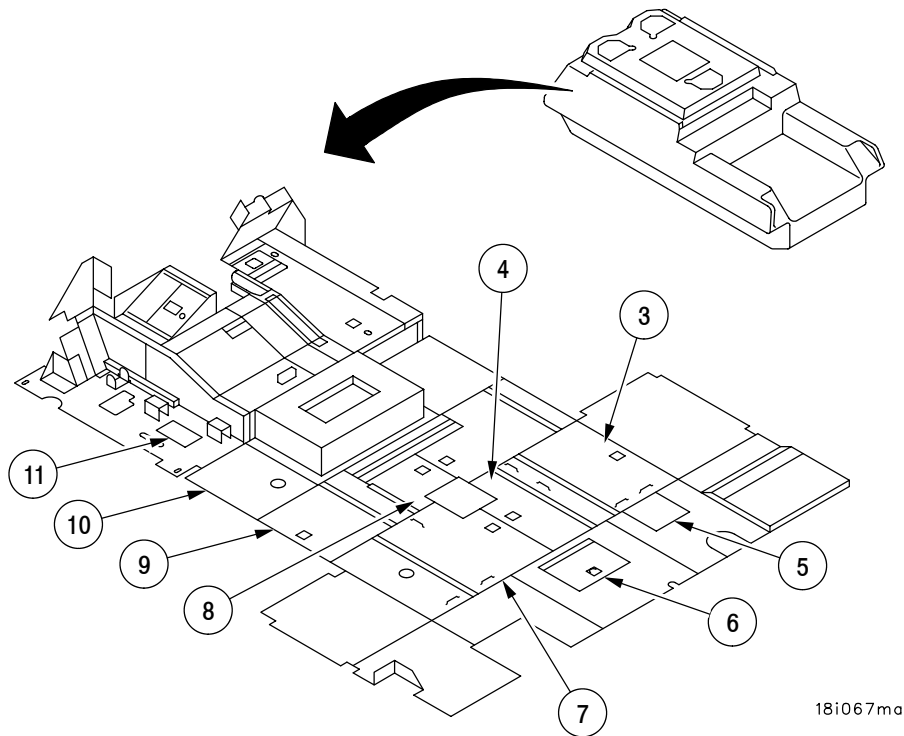

18i067ma

END OF TASK

ADJUSTING COMMANDER'S SEAT**0038 00****THIS WORK PACKAGE COVERS:**

Adjusting Commander's Seat

1. Seat rotation - Step on seat rotation foot pedal (1), rotate seat to desired position, then release foot pedal.

NOTE

The seat rotation control will keep seat from rotating only when seat is positioned directly forward or backward in the vehicle. The seat will continue to rotate when in any other position.

2. Seat dump - Remove pin (2), move seat forward until alternate holes align. Install pin (2).

NOTE

Have weight on seat when performing the next three steps.

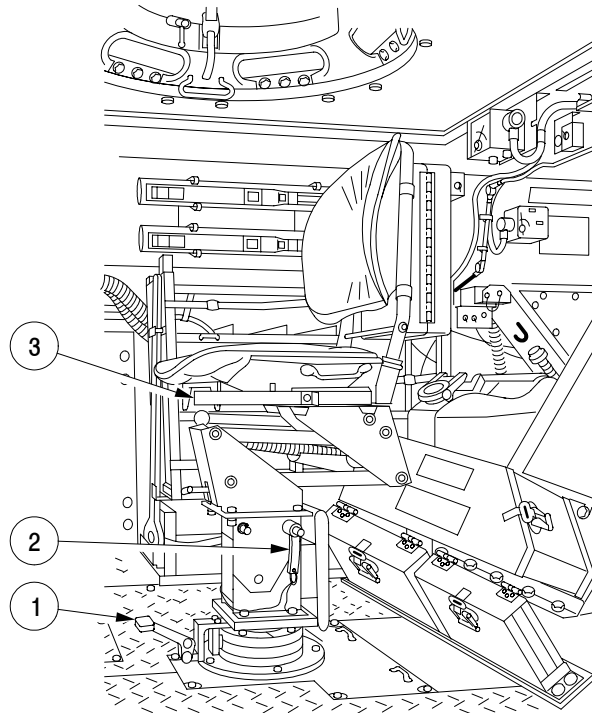

181063ma

3. Horizontal adjustment - Push lever (3) inward and hold, adjust seat forward/backward to desired position, then release lever (3).

ADJUSTING COMMANDER'S SEAT - CONTINUED**0038 00**

4. Tilt adjustment - Pull handle (4) outward and hold, tilt seat to desired position, release handle (4).
5. Height adjustment - Pull lever (5) upward and hold, adjust seat height to desired position, then release lever (5).

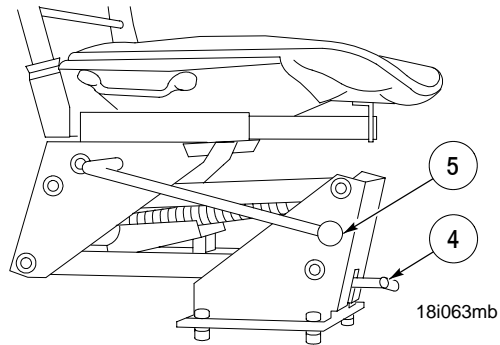
**END OF TASK**

OPERATE AUXILIARY BOOM**0039 00****THIS WORK PACKAGE COVERS:**

Removing Auxiliary Boom, Using Auxiliary Boom, Stowing Auxiliary Boom

INITIAL SETUP:**Tools and Special Tools**

Socket wrench set (item 38, Table 2, WP 0133 00)
 Auxiliary boom (item 1, Table 1, WP 0133 00)
 12.5 ton shackle (item 39, Table 1, WP 0133 00)
 Chain hoist (item 8, Table 1, WP 0133 00)

Personnel Required

Three

Equipment Conditions

Main engine shutdown (WP 0019 00)

References

WP 0133 00
 WP 0019 00

The vehicle is equipped with an auxiliary boom which is used in conjunction with the chain hoist for lifting and moving heavy equipment stowed on the vehicle.

REMOVING AUXILIARY BOOM

1. Remove screw (1), lockwasher (2), and flat washer (3) securing auxiliary boom (4) to vehicle.
2. Remove auxiliary boom from holder (5).

USING AUXILIARY BOOM**WARNING**

Auxiliary boom maximum weight limit is 500 lbs (227 kg). Do not exceed limit or boom may fail, causing injury or DEATH to personnel.

1. Place round end of auxiliary boom into one of eight receptacles (6) closest to the object to be lifted.

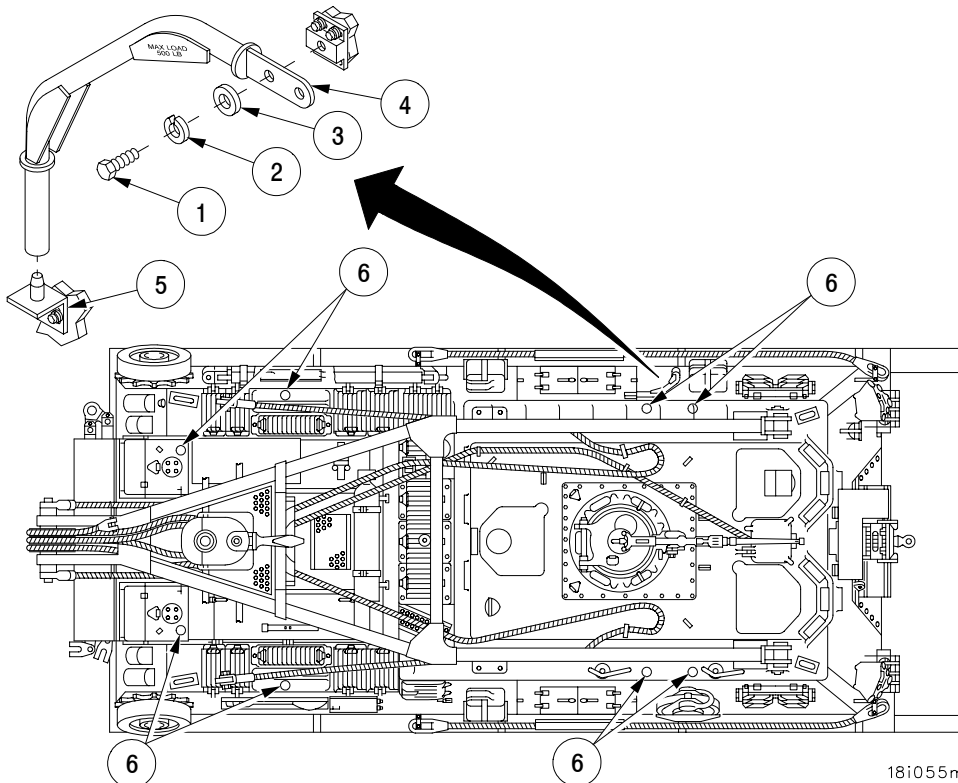

18i055ma

OPERATE AUXILIARY BOOM - CONTINUED**0039 00****USING AUXILIARY BOOM - CONTINUED**

2. Attach 12.5 ton shackle (7) to auxiliary boom end.
3. Connect chain hoist (8) to auxiliary boom end.
4. Connect chain hoist (8) hook to object.
5. Lift object with chain hoist (8).

STOWING AUXILIARY BOOM

1. Disconnect chain hoist (8) from object and auxiliary boom.
2. Remove 12.5 ton shackle (7) from auxiliary boom. Stow shackle in proper location.
3. Remove auxiliary boom from receptacle (6).
4. Insert round end of auxiliary boom onto holder (5).
5. Install screw (1), lockwasher (2), and flat washer (3) to secure auxiliary boom to vehicle.

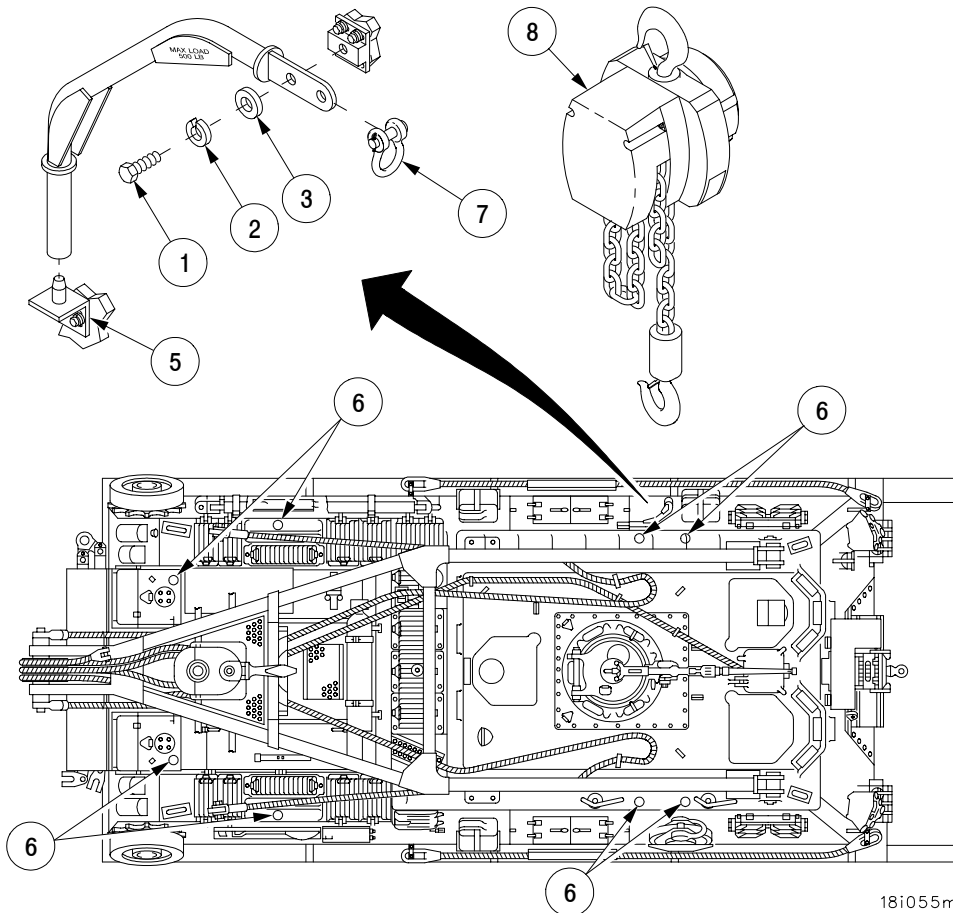

18i055mb

END OF TASK

TOWING OPERATION

0040 00**THIS WORK PACKAGE COVERS:**Towing Operation

INITIAL SETUP:**Personnel Required**

Three

References

WP 0041 00

FM 9-43-2

NOTE

Operational Risk Assessment (ORA) must be completed prior to every 70-ton class vehicle towing mission.

Perform Operational Risk Assessment as follows:

1. Operational Risk Assessment (ORA) must be completed prior to every 70-ton class vehicle towing mission.
2. Reproduce the matrix found in this work package locally as needed.
3. Fill out the ORA matrix form, taking into consideration the following conditions:
 - Driver/TC Experience
 - Visibility (weather conditions)
 - Terrain (including surface conditions and slope)
 - Use of hold back vehicle and its associated hazards.
4. Total "risk factor(s)" given to each category and enter on "TOTAL RISK" line.
5. Have the ORA reviewed by the appropriate decision authority (depending upon the risk level) to either ACCEPT or REJECT the risk assessments required for the mission.
6. To reduce the risk level, it may be necessary to consider one or more of the following:
 - Request a more experienced driver.
 - Wait for better weather.
 - Identify a better route through the terrain.

TOWING OPERATION - CONTINUED

0040 00

TOWING OPERATIONAL RISK ASSESSMENT*

UNIT _____ OPERATOR _____ TC _____ DATE _____

RECOVERY VEHICLE BUMPER # _____ TOWED LOAD _____

M88A2 EXPERIENCE	0-6 Months	7-12 Months	13-24 Months	25+ Months	RISK
DRIVER	(4)	(3)	(2)	(1)	
TC	(4)	(3)	(2)	(1)	

VISIBILITY		Reduced Visibility	Clear	
DAY	Reduced Visibility (RAIN, FOG & DUST)		(1)	(0)
NIGHT	(Includes the use of NVG's)		(2)	

SURFACE CONDITIONS		Wet	Dry	
ASPHALT, CONCRETE		(2)	(1)	
		Wet	Dry	
SECONDARY ROADS (Hard Packed Gravel)	(4)	(3)		
LOOSE CONDITIONS (Sand, Dirt, Loose Gravel)	(4)			
MUD & CLAY	(5)			
SNOW/ICE	RECOMMENDED USE OF A HOLD BACK VEHICLE			

SLOPE				
0-5%			(1)	
6-10%			(2)	
11-14%		(3)		
15-19%	(5)			
20-22%	(6)			
23%+	RECOMMENDED USE OF A HOLD BACK VEHICLE			

TOTAL RISK	
-------------------	--

(5-10) MEDIUM
PLT LDR/SGT

(11-16) HIGH
CO CDR/XO

(17+) RECOMMEND
HOLD BACK VEHICLE

TC SIGNATURE _____ VERIFYING AUTHORITY _____

- *Risk Assessment must be completed prior to 70 ton class vehicle Towing Operation
- *In conditions assessed a high risk, commanders may require the use of a hold-back vehicle
- *OC&S has experienced difficulties at 15%+ slopes and under degraded soil conditions. A hold-back vehicle may be recommended.
- *All slopes 15% and above must be signed off by the Company Commander.
- *Cross-Country Tow w/cables requires a hold-back vehicle (TM 9-43-2)
- Cross-Country Tow requires Como between towing vehicle and hold-back vehicle.
- *Combat Tow does not require hold-back vehicle.

REPRODUCE

WARNING

Do not exceed maximum speeds for towing with tow bar or tow cables. Failure to comply may result in injury or DEATH to personnel or damage to equipment.

7. Towing a disabled vehicle requires use of towing pintle and tow bar (WP 0041 00). When towing a vehicle, maintain the following speeds: 5 to 17 mph (8 to 27 kmph) (2nd gear from 5 to 12 mph) over hard, level, smooth road or 3 mph (5 kmph) (1st gear) over hilly, cross-country ground. These figures are maximum speeds. Go slower if towing on steep slopes or disabled vehicle's technical manual specifies slower speeds. The following precautions will be followed to ensure safety to personnel and equipment.

WARNING

Do not stand between vehicles while engine(s) are running. Vehicle could jump and crush personnel between vehicles. Failure to comply may result in injury or DEATH to personnel.

8. Vehicle engines will be shut off and brakes applied with transmission selector lever in park (P) position while any towing device is being connected or disconnected.
9. The main gun on towed vehicles will be pointed away from the M88A2 to prevent impact in case of a collision.
10. Exhaust deflector will be placed in full-up position during towing operations.
11. An observer will be used to assist the operator during towing operations.
12. Personnel will not ride on or in a vehicle being towed with the tow bar.
13. Sharp turns or sudden stops will be avoided. Make wide gradual turns made up of many little turns in first gear.
14. The driver of the M88A2 will exercise good judgement whenever a vehicle is being towed.
15. If the transmission temperature gauge reaches 260° F (127° C), the following procedure will be carried out regardless of terrain (i. e. level ground, slope, etc.):
 - Stop vehicle, set brakes and place transmission shift selector in park (P) position.
 - Set engine speed between 2200 and 2400 rpm. Running at high rpm will cool transmission fluid.
 - Maintain this position until transmission fluid temperature drops below 240° F (116° C).
 - Proceed with towing operation while monitoring transmission temperature gauge.
 - Repeat procedure as required.

END OF TASK

TOW DISABLED VEHICLE**0041 00****THIS WORK PACKAGE COVERS:**

Tow Disabled Vehicle, Towing Disabled M88A2, Operational Restrictions When Towing an Abrams FOV, Description of Surveying Level, Measuring a Slope

INITIAL SETUP:**Tools and Special Tools**

Surveying level (item 26, Table 1, WP 0133 00)
18-ton shackles (2) (item 40, Table 1, WP 0133 00)

Personnel Required

Three

References

WP 0040 00
WP 0043 00
WP 0082 00
WP 0044 00
FM 9-43-2
WP 0133 00

TOW DISABLED VEHICLE

1. Follow all information in WP 0040 00 to ensure safety to personnel and equipment.
2. Position M88A2 in front of or behind disabled vehicle.
3. Connect tow bar (WP 0043 00) to both vehicles.
4. Refer to disabled vehicle's technical manual for specific towing instructions (gear position, final drive disconnected, towing speed, etc).
5. Shift transmission selector to first gear to get rolling and then shift to second gear only if using tow bar and ground conditions permit.

CAUTION

These speeds are for good ground conditions. Go slower up and down hills. Do not exceed 3 mph (5 kmph) on steep slope. Failure to comply may result in loss of control and cause damage to equipment.

6. For towing on hard, flat ground with tow bar, keep speed under 17 mph (27 kmph). When towing cross-country, keep maximum speed under 3 mph (5 kmph). For towing on unusual terrain refer to WP 0082 00.

CAUTION

Verify percentage of slopes before descending and/or ascending hills. Failure to comply may result in loss of control and cause damage to equipment.

7. For towing on slopes (uphill or downhill) use surveying level to measure slopes.
8. To steer the vehicles, use a series of short turns. This will help keep the vehicles in line.

TOWING DISABLED M88A2

1. Position recovery vehicle in front of or behind disabled M88A2.
2. Connect tow bar (WP 0043 00) or tow cables (WP 0044 00) to both vehicles.
3. Shift transmission selector in disabled M88A2 to neutral (N). For vehicles with improved park brake, place MASTER switch ON.
4. Do not use the disabled M88A2's brakes continuously, they will burn out.
5. Do not disconnect the final drives unless transmission problems are suspected. If transmission problems are suspected, disconnect the final drives to prevent further damage to the transmission. If the M88A2 is going to be towed with cables, have a third vehicle hookup with cables behind the disabled M88A2 to act as a braking unit. Refer to FM 9-43-2 for procedures.

TOW DISABLED VEHICLE - CONTINUED**0041 00****TOWING DISABLED M88A2 - CONTINUED**

6. Do not tow the M88A2 backwards with the final drives connected. Always disconnect the final drives before towing backward.

CAUTION

Make sure the parking brake on the vehicle being towed is released. Failure to comply could result in equipment damage due to dragging brake.

- 6A. If parking brake will not release due to failure of the electrical or hydraulic system, brake must be manually released.
7. Do not tow the M88A2 faster than 17 mph (27 kmph) with a tow bar on level ground, or faster than 3 mph (5 kmph) with tow bar towing cables over rough ground.

MANUAL RELEASE OF M88A2 ENHANCED PARKING BRAKE

1. Remove floor plate #9 (WP 0036 00).
2. Remove cotter pin (1), pin (2), and two flat washers (3) from ball joint assembly (4).
3. Turn ball joint assembly (4) until tension is released from threaded rod (5) releasing vehicle brake.
4. After towing vehicle, notify unit maintenance that floor plates have been removed and vehicle brake has been released.

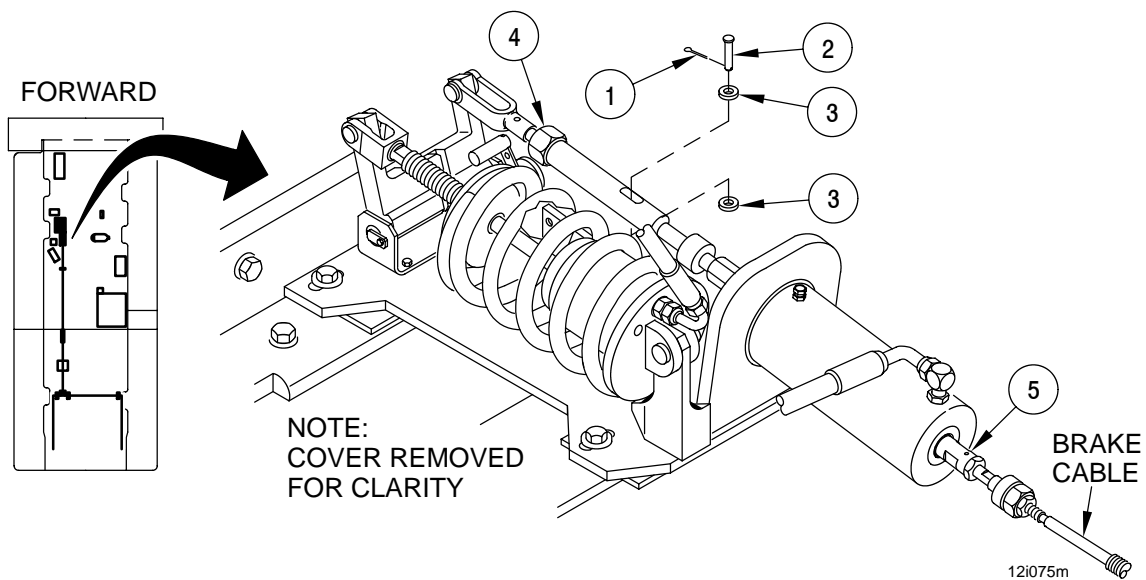

TOWING DISABLED M88A2 - CONTINUED

OPERATIONAL RESTRICTIONS WHEN TOWING AN ABRAMS FOV

1. Use an M88A2 HERCULES Recovery vehicle as the tow vehicle.
2. Use an M88A2 HERCULES Recovery vehicle or another Abrams FOV when a braking or holdback vehicle is required.
3. Use crossed tow cables as the method for attaching the braking or holdback vehicle. Connect tow cables using two 18-ton shackles to Abrams FOV towing eyes as shown. Do not connect tow cables to Abrams lifting eyes.

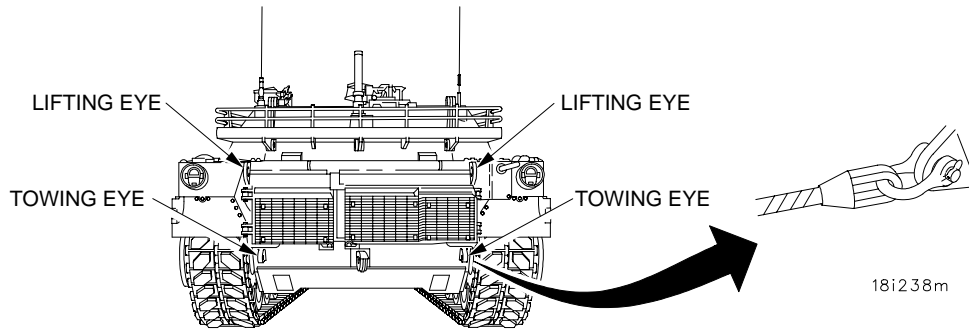

4. Use the tow bar provided with the M88A2 HERCULES for the tow vehicle.
5. When towing cross-country under extreme conditions, use crossed cables for both the towing and braking or holdback vehicle.
6. When properly hooked up, they should look like this:

HERCULES W/TOW BARS - HERCULES AS BRAKING VEHICLE

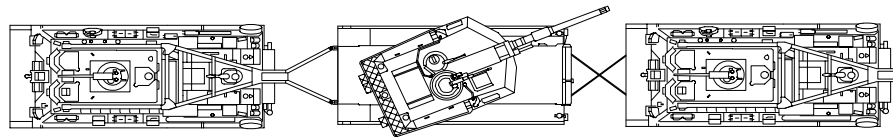

HERCULES W/TOW BARS - ABRAMS AS BRAKING VEHICLE

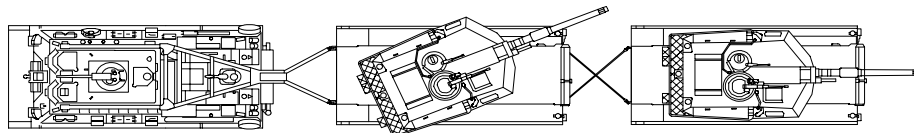

HERCULES W/CROSS CABLES - HERCULES AS BRAKING VEHICLE

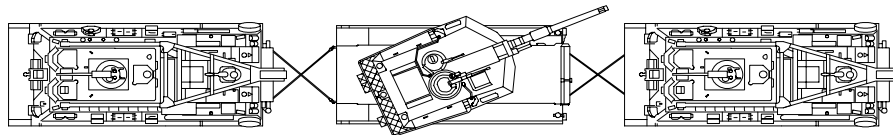

HERCULES W/CROSS CABLES - ABRAMS AS BRAKING VEHICLE

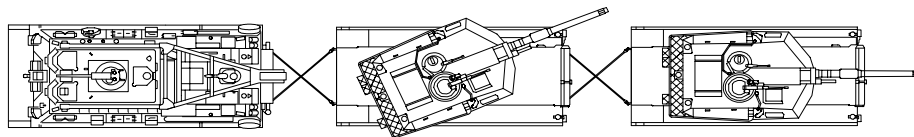

18i237m

TOW DISABLED VEHICLE - CONTINUED**0041 00****DESCRIPTION OF SURVEYING LEVEL**

The surveying level is an instrument used for measuring slopes. The instrument consists of a square metal sighting tube (1) on which an arc (2) is mounted with an index arm (3) holding a level vial (4). Inside tube (1), right of the arc, is a mirror which reflects the image of bubble on level vial (4) to eye piece (5). A cross line (6) is mounted horizontally inside sighting tube (1) and is used to align on the target. The leveling vial (4) is mounted on the index arm (3) so that it can be rotated. The amount of rotation can be read on scale (7) of the arc (2) on index arm (3). Setting knob (8) provides slow motion adjustment of index arm (3). The index arm thumb nut (9) can be tightened to lock the index arm.

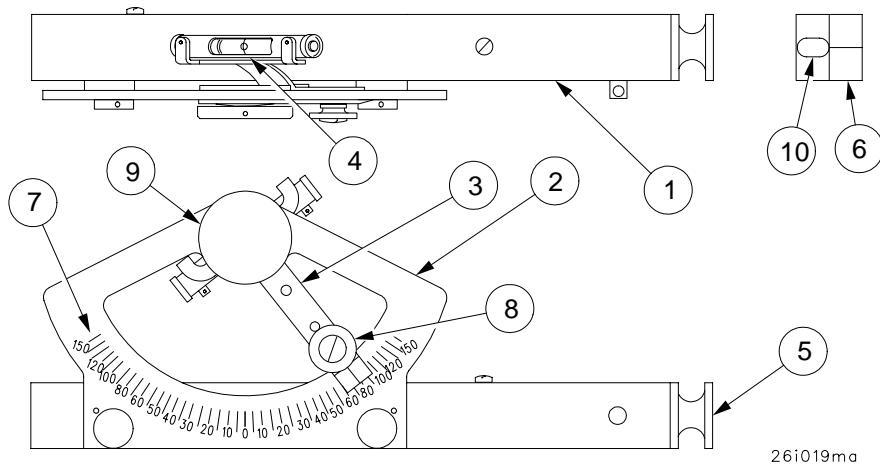

26i019ma

MEASURING A SLOPE**WARNING**

Do not exceed an uphill or downhill slope of 30 percent during any towing operations. Failure to comply will result in possible serious injury or DEATH to personnel or damage to equipment.

1. Using surveying level sight target by looking through eye piece (5) aligning cross line (6) (left side) on the top of the slope if going uphill or the bottom of the slope if going downhill.
2. While sighting on target with cross line (6), move index arm (3) for coarse adjustments, or turn setting knob (8) for slow motion adjustment until center level vial bubble (10) is aligned with cross line (6).
3. If necessary, lock index arm (3) by tightening thumb nut (9) and read slope percentage indicated by index arm (3) on scale (7).

END OF TASK

OPERATE PINTLE.**0042 00****THIS WORK PACKAGE COVERS:**

Operate Pintle

INITIAL SETUP:**Personnel Required**

Two

Equipment Conditions

Vehicle parked and brakes locked, main engine shutdown (WP 0019 00)

References

WP 0019 00

1. Remove cotter pin (1) from towing pintle.
2. Pull locking handle (2) upward.
3. Lift pintle lock (3) of towing pintle.
4. Place tow bar in towing pintle.
5. Close pintle lock (3) and insert cotter pin (1).

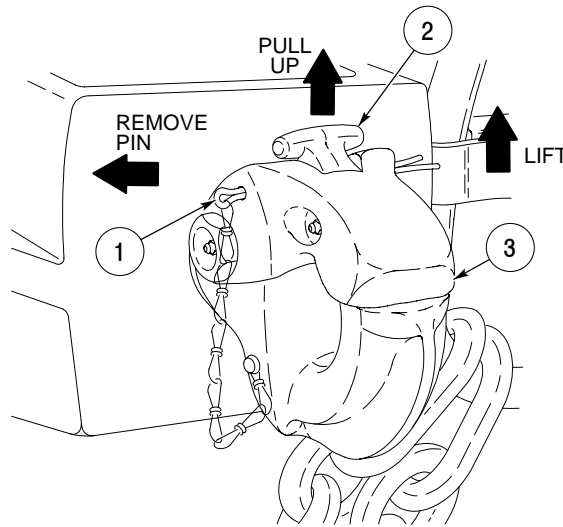

18i017m

END OF TASK

OPERATE TOW BAR**0043 00****THIS WORK PACKAGE COVERS:**

Deploying Tow Bar, Connecting Tow Bar, Disconnect Tow Bar, Stowing Tow Bar

INITIAL SETUP:**Tools and special Tools**

Socket wrench set (item 38, Table 2, WP 0133 00)
 Sling (item 43, Table 1, WP 0133 00)
 Chain Hoist (item 8, Table 1, WP 0133 00)

Personnel Required

Three

Equipment Conditions

Vehicle parked and brakes locked; main engine shut down (WP 0019 00)

References

WP 0012 00
 WP 0019 00
 WP 0042 00
 WP 0133 00

The vehicle is equipped with two tow bars. One is stowed above towing pintle and a spare is stowed on left side of vehicle. Do not exceed 17 mph (27 kmph) while towing disabled vehicle with tow bar. Make wide sweeping turns made up of many smaller turns to keep both vehicles in line while towing.

DEPLOYING TOW BAR

1. Loosen nuts (1) that secure deflector assembly brackets (2) to engine deck studs (3).
2. Position deflector assembly (4) in full-up position and secure nuts (1).
3. Loosen nuts (5) and open clamps (6).

WARNING

Tow bar weighs 280 lbs (127.1 kg). Use chain hoist to remove, deploy and stow tow bar. Failure to comply may result in injury to personnel.

4. Secure sling to tow bar (7).
5. Attach chain hoist to lifting eye (8) and sling.
6. Remove tow bar (7) from clamps (6) using chain hoist.
7. Lower tow bar (7) to ground and remove chain hoist and sling.

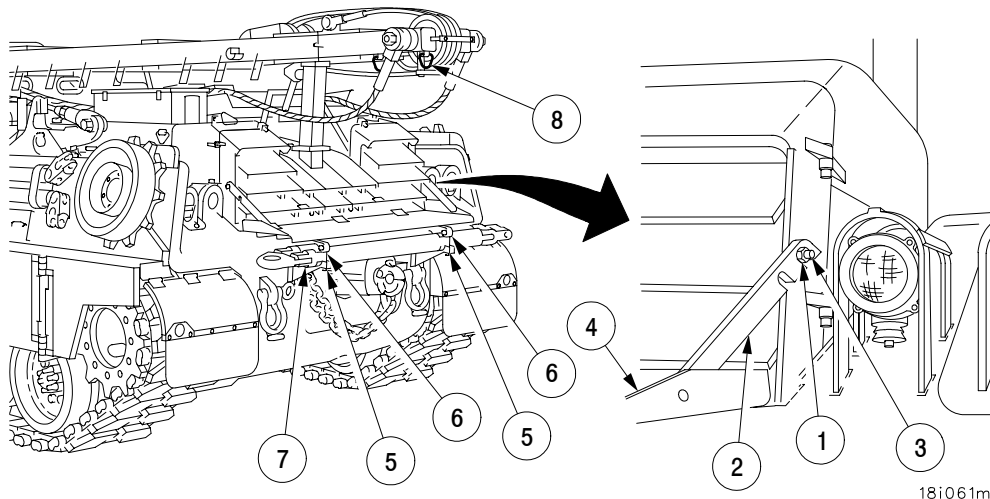

18i061m

OPERATE TOW BAR - CONTINUED**0043 00****CONNECTING TOW BAR**

1. Install pin (9) and locking pin (10) in tow bar (7).
2. Remove locking pins (11) and clevis pins (12) from clevis (13) of tow bar (7).

CAUTION

When attempting to tow Abrams combat tank, always connect tow bar to smaller of two holes in tank's upper lifting eyes on front of vehicle.

Make sure clevis markings "**TOW↑BAR**" are facing upward with arrow pointing towards tow bar when securing clevis to tow lugs of disabled vehicle or upper lifting eyes on front of Abrams FOV. Failure to comply will result in equipment damage.

3. Place clevis (13) over the tow lugs (14) of disabled vehicle or smaller of two holes in the upper lifting eyes on front of Abrams and insert clevis pins (12) and locking pins (11).

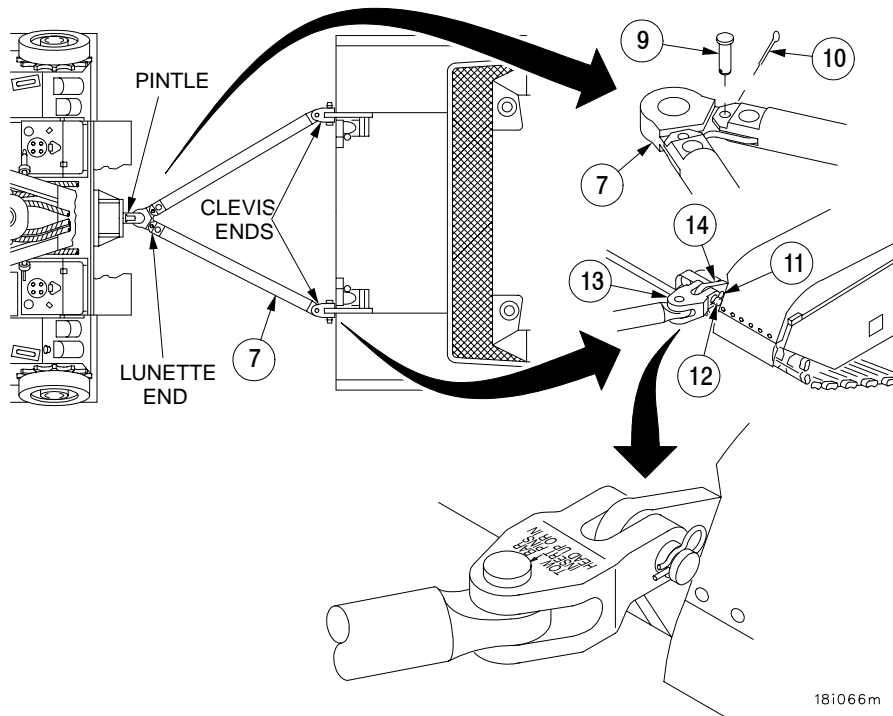

181066m

CONNECTING TOW BAR - CONTINUED**WARNING**

4. Position M88A2's towing pintle in front of tow bar (7), then apply brakes, shift transmission selector lever to park (P) to lock brakes, and shut off engine (WP 0019 00).
5. Connect the chain hoist and sling to the tow bar (7).
6. Lift the tow bar (7) with the chain hoist until it is at the same height as the towing pintle.
7. Open the towing pintle (WP 0042 00).

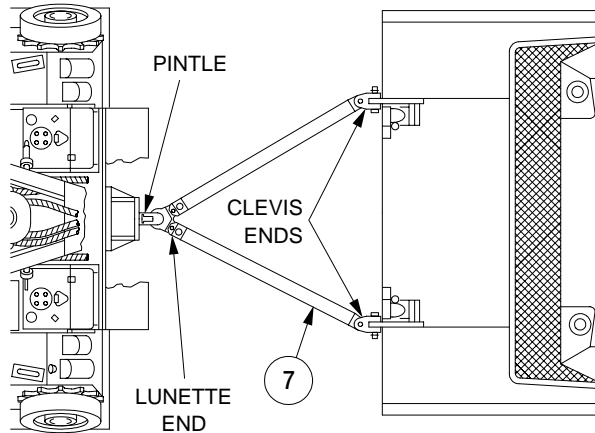

18i066mb

OPERATE TOW BAR - CONTINUED

0043 00**CONNECTING TOW BAR - CONTINUED****WARNING**

Stay out from between vehicles while M88A2 is being positioned. Failure to comply may result in personnel being crushed.

Use two ground guides to direct operator while backing vehicle. Inadequate guidance during backing operations may result in accidental impact causing injury or DEATH to personnel or damage to equipment.

8. Start main engine (WP 0012 00) and back the M88A2 until lunette end of tow bar (7) is connected to towing pintle (WP 0042 00).
9. Apply brakes, shift transmission selector lever to park (P) to lock brakes. Shut down the main engine (WP 0019 00).
10. Close and secure towing pintle (WP 0042 00).
11. Disconnect chain hoist and remove sling from tow bar (7).
12. Check disabled vehicle's technical manual for any special towing procedures before towing.

DISCONNECTING THE TOW BAR**WARNING**

Make sure disabled vehicle will not move after it is disconnected from M88A2. If final drives of disabled vehicle were disconnected for towing, disabled vehicle will not have any brakes. Chock the towed vehicle before moving between vehicles to disconnect the tow bar. Failure to comply may result in movement of the disabled vehicle causing injury or DEATH to personnel or damage to equipment.

1. Chock the towed vehicles.
2. Secure sling to tow bar.
3. Connect the chain hoist to sling on tow bar and lifting eye.

OPERATE TOW BAR - CONTINUED**0043 00****DISCONNECTING THE TOW BAR - CONTINUED**

4. Open towing pintle (WP 0042 00) and lift tow bar (7) with chain hoist until it is clear of towing pintle.
5. Start main engine (WP 0012 00).
6. Move the M88A2 forward until lunette end of tow bar (7) is clear of towing pintle.
7. Depress brakes, shift transmission selector lever into park (P) to lock brakes. Shut down main engine (WP 0019 00).
8. Lower tow bar (7) to ground and remove chain hoist and sling.
9. Close and secure towing pintle (WP 0042 00).
10. Remove locking pins (11) and clevis pins (12) from clevis (13) of tow bar (7) and remove tow bar (7) from disabled vehicle tow lugs (14).
11. Insert clevis pins (12) and locking pins (11) into clevis (13) of tow bar (7).
12. Remove locking pin (10) and pin (9) from tow bar (7).

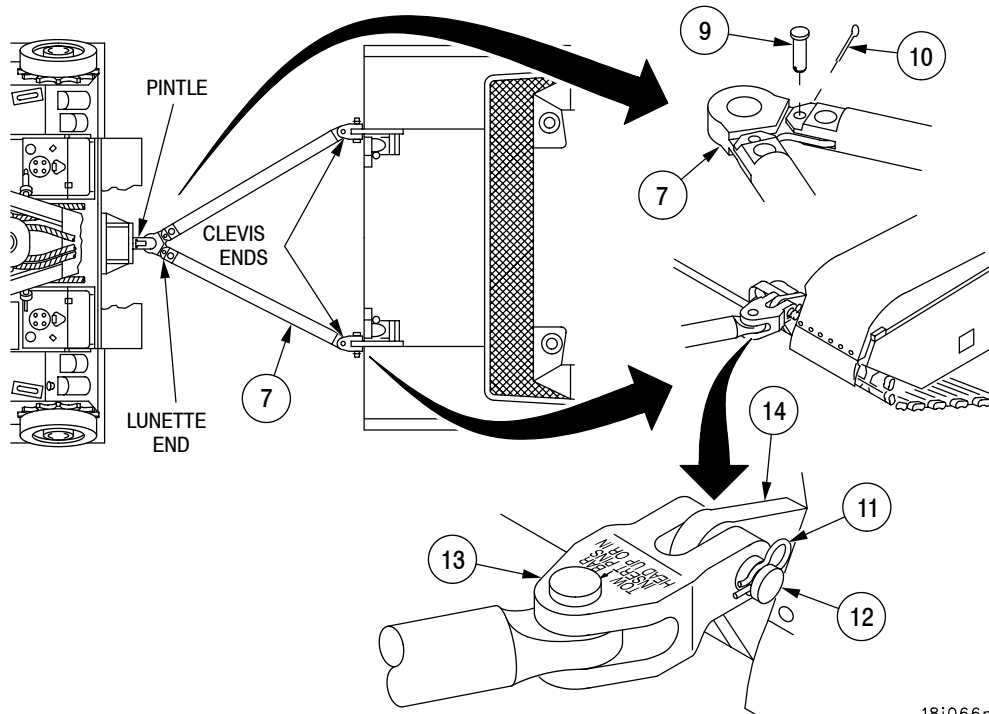

18i066mc

OPERATE TOW BAR - CONTINUED**0043 00****STOWING TOW BAR****WARNING**

Tow bar weighs 280 lbs (127.1 kg). Use chain hoist to remove, deploy and stow tow bar. Failure to comply may result in injury to personnel.

1. Secure sling to tow bar (7).
2. Attach chain hoist to lifting eye (8) and sling.
3. Position tow bar (7) in clamps (6) using chain hoist.
4. Tighten nuts (5) in clamps (6) to secure.
5. Disconnect chain hoist and remove sling from tow bar (7).
6. Loosen nuts (1) securing deflector assembly brackets (2) to engine deck studs (3).
7. Position deflector assembly (4) at full-down position and secure nuts (1).

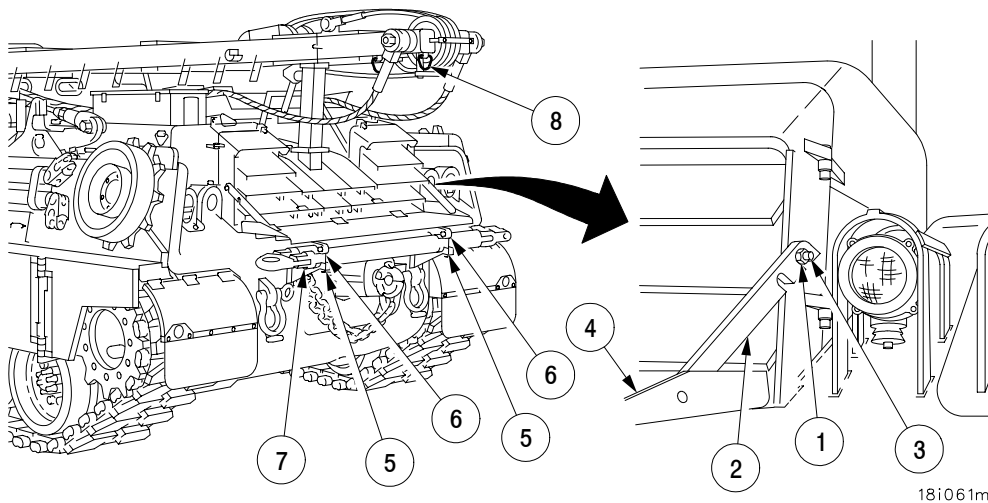
**END OF TASK**

OPERATE TOW CABLES**0044 00****THIS WORK PACKAGE COVERS:**

Deploying Cables, Connecting Cables, Disconnecting Cables, Stowing Cables

INITIAL SETUP:**Tools and special Tools**

Socket wrench set (item 38, Table 2, WP 0133 00)
50-ton shackles (4) (item 41, Table 1, WP 0133 00)

Personnel Required

Three

Equipment Conditions

Vehicle parked and brakes locked; main engine shut down (WP 0019 00)

References

WP 0019 00
WP 0041 00
FM 9-43-2

The vehicle is equipped with two tow cables. The cables are stowed on left and right side of vehicle. Tow cables are used in extreme cases or as a backup when traveling over rough ground (cross-country) (refer to FM 9-43-2) only when the tow bar is not available for use. Do not exceed 3 mph (5 kmh) while towing disabled vehicle with tow cables. Make wide sweeping turns made up of many smaller turns to keep both vehicles in line while towing.

DEPLOYING CABLES**NOTE**

Use only the M88A2 COEI provided equipment. Do not use other vehicles COEI items as it may not have the same capabilities as the M88A2 shackles and tow cables.

Tow cables from the brake vehicle to the towed vehicle must cross to form an "X" between the brake vehicle and towed vehicle. The cable connected to the left side of the brake vehicle must always cross under the cable connected to the right side of the brake vehicle.

When towing cross-country under extreme conditions, use crossed cables for both the towing and braking or holdback vehicle. Use an M88A2 as the tow vehicle.

1. Loosen four screws (1) on each end and open two tow cable retainers (2).
2. Remove two screws (3) and tow cable clamp (4).
3. Remove cable from vehicle.
4. Repeat procedures for other cable.
5. Position cable retainers (2) and tighten screws (1) so as not to lose them during towing operation.
6. Install cable clamps (4) and screws (3) so as not to lose them during towing operation.

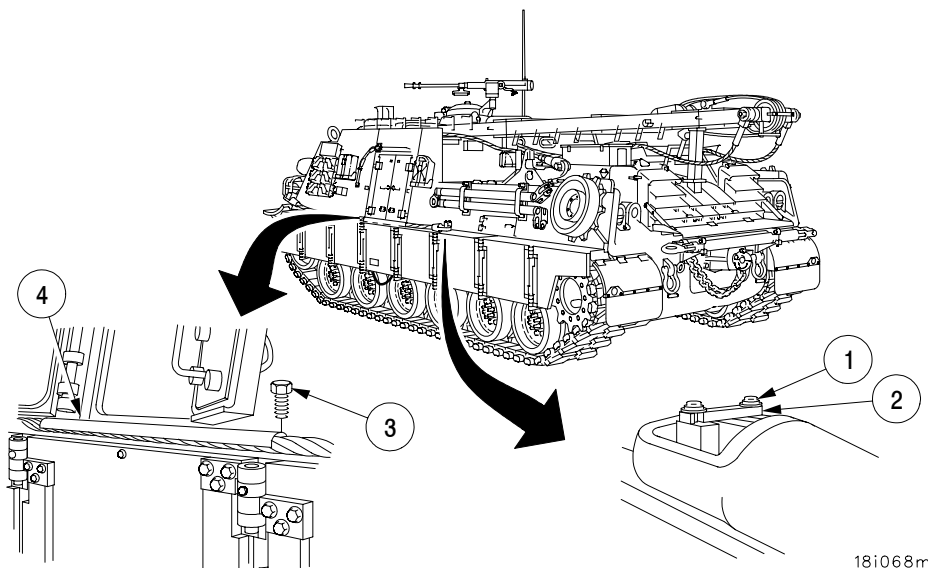

181068m

OPERATE TOW CABLES - CONTINUED**0044 00****CONNECTING CABLES****WARNING**

Stay out from between vehicles while M88A2 is being positioned. Failure may result in personnel being crushed between vehicles.

**WARNING****WARNING**

Do not bend or loop cables when rigging vehicle for towing. This will weaken cables and cause them to break. Failure to comply may result in injury or DEATH to personnel or damage to equipment.

1. Position M88A2 in front or rear of disabled vehicle, depress brakes, shift transmission selector lever to park (P) to lock brakes. Shut down engine (WP 0019 00).
2. Remove four locking pins (5) and four clevis pins (6) from four 50-ton shackles (7).
3. Install 50-ton shackles (7) on ends of tow cables.

WARNING

Ensure locking pins are securely fastened in clevis pins to avoid separation of tow cable from vehicle. Failure to comply may result in injury or DEATH to personnel or damage to equipment.

4. For towing, connect 50-ton shackles (7) to front lifting eyes of disabled vehicle, and rear towing lugs, upper eyes only, on M88A2. Install four clevis pins (6) and four locking pins (5). Tow cables should cross when installed properly.

NOTE

Shackles will not fit rear towing eyes of all vehicles. Use highest strength shackle available for each application. See WP 0041 00 for Abrams FOV.

OPERATE TOW CABLES - CONTINUED**0044 00****CONNECTING CABLES - CONTINUED**

5. For braking vehicle, connect shackles (7) to rear towing eyes of disabled vehicle and front towing lugs, upper eyes only, on the M88A2.

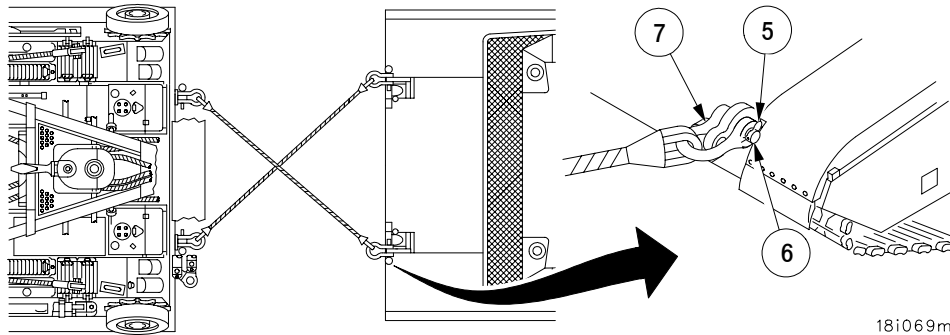
**CAUTION**

Check disabled vehicle's technical manual for specific procedures for towing.

WARNING

Use third vehicle to hold back disabled vehicle. Refer to FM 9-43-2 for procedures. Failure to comply may result in a collision which may result in injury or DEATH to personnel or damage to equipment.

Do not exceed 3 mph (5 kmph). Failure to comply may result in a collision which may result in injury or DEATH to personnel or damage to equipment.

6. Begin towing. Do not exceed 3 mph (5 kmph) while towing.

OPERATE TOW CABLES - CONTINUED**0044 00****DISCONNECTING CABLES**

1. Remove tension from cables before removing cables.

WARNING

Shut off engine(s) and lock brakes on both vehicles before going between them. Vehicle may jump and crush personnel against other vehicle. Failure to comply may result in injury or DEATH to personnel.

Ensure disabled vehicle will not move after it is disconnected from M88A2. If final drives of disabled vehicle were disconnected for towing, disabled vehicle will not have any brakes. Chock the towed vehicle before moving between vehicles to disconnect the tow cables. Failure to comply may result in movement of the disabled vehicle causing injury or DEATH to personnel or damage to equipment.

2. Chock the towed vehicle.
3. Remove four locking pins (5), four clevis pins (6) and four shackles (7) from lifting eyes/tow lugs of towed vehicle and M88A2.
4. Remove shackles from ends of tow cables.
5. Install clevis pins (6) and locking pins (5) in shackles and stow shackles.

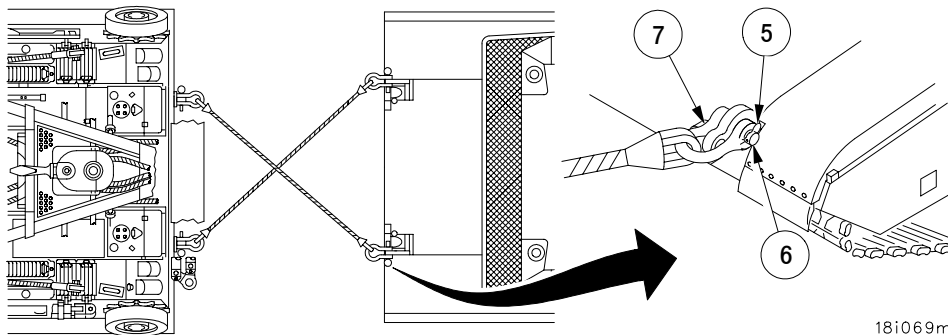

18i069m

OPERATE TOW CABLES - CONTINUED**0044 00****STOWING CABLES**

1. Remove two screws (3) and cable clamps (4).
2. Loosen four screws (1) and open cable retainers (2).
3. Position cable on vehicle.
4. Position cable retainers (2) and tighten four screws (1).
5. Install cable clamps (4) and two screws (3).
6. Repeat procedures for other cable.

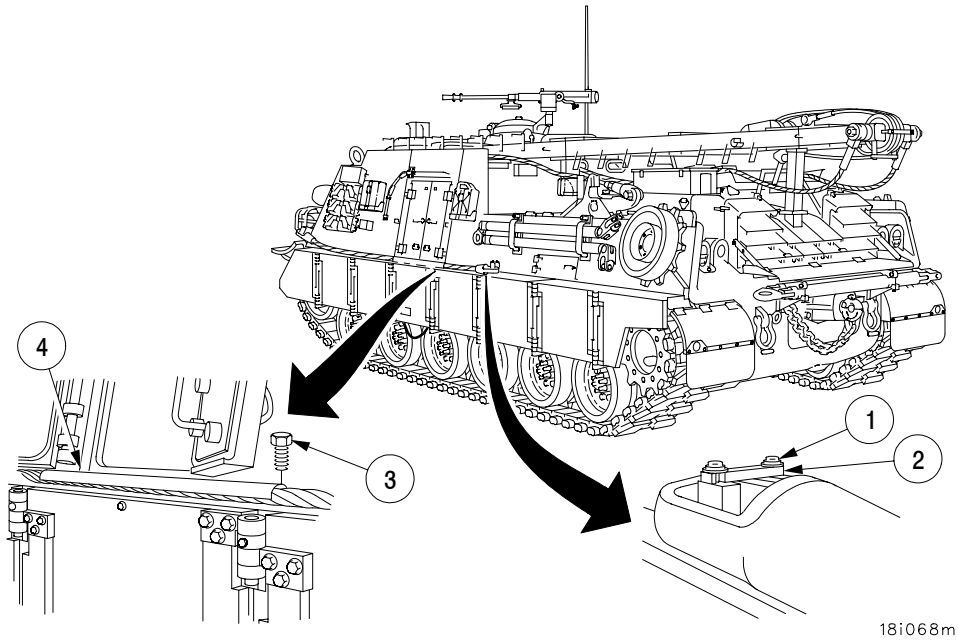
**END OF TASK**

PREPARING HYDRAULIC SYSTEM FOR OPERATION

0045 00

THIS WORK PACKAGE COVERS:

Main Hydraulic System, Emergency Engagement/Disengagement of the PTO Clutch, Auxiliary Hydraulic System

INITIAL SETUP:

Tools and special Tools

Adjustable wrench (item 40, Table 2, WP 0133 00)

Equipment Conditions

Vehicle parked and brakes locked; main engine shut down (WP 0019 00)

References

- WP 0012 00
- WP 0019 00
- WP 0133 00
- WP 0053 00
- WP 0054 00
- WP 0055 00

CAUTION

Do not operate hydraulic system with hoses disconnected. Failure to comply may result in damage to equipment.

MAIN HYDRAULIC SYSTEM

1. Start main engine (WP 0012 00) and warm it up.
2. Ensure all hydraulic control levers are in NEUTRAL, HOLD, or LIVE.
3. Ensure SYSTEM SELECTOR control valve (1) is in MAIN position.
4. Move PTO CLUTCH switch (2) to ON.

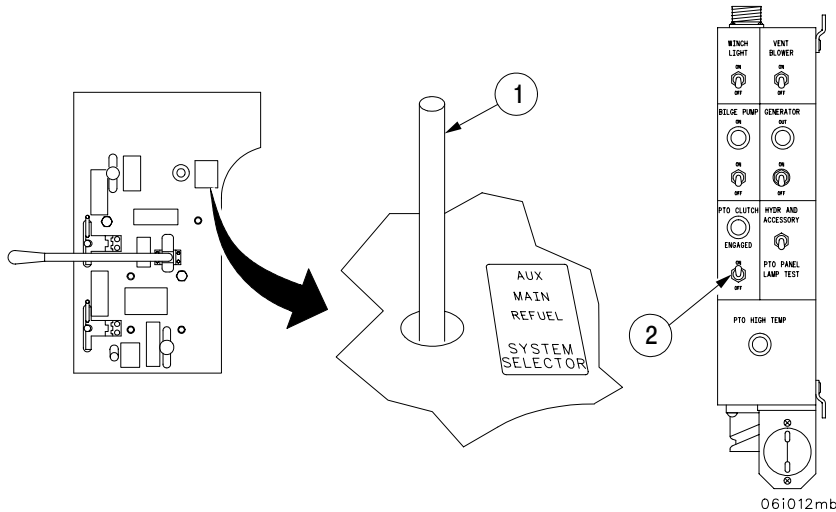

NOTE

For cold weather operation - set engine speed to 1,800 rpm. Check that spade lock is locked and move SPADE operating lever to RAISE for 3 to 4 minutes. This will cause oil to spill over the relief valve for faster warmup.

For hot weather or continuous operation, increase engine speed to 2000 rpm to help cool hydraulic fluid.

5. For normal operation, set engine speed to 1800 rpm.

CAUTION

Sustained hydraulic operation above 225°F (107°C) is not recommended. High oil temperatures may cause abnormal system performance. Failure to comply may result in damage to equipment.

6. Main hydraulic system is now ready for operation.

EMERGENCY ENGAGEMENT/DISENGAGEMENT OF THE PTO CLUTCH

WARNING

Manual clutch lock lever is under heavy tension. Maintain tension on manual lock lever at all times while disengaging/engaging PTO clutch to avoid a rapid manual lock lever rotation. Failure to comply may result in injury to personnel.

NOTE

The PTO clutch is equipped with a manual clutch lock in case the PTO CLUTCH toggle switch or associated wiring malfunctions.

For proper operation of engine RPM limit and hydraulic oil cooling, make sure PTO clutch switch is ON when operating with the PTO manually engaged.

Engagement

1. Shut down main engine (WP 0019 00).
2. Remove four bolts (1) with captive lockwashers, four flat washers (2) and remove floor plate (3) over electromagnetic clutch.
3. Pull manual clutch lock lever knob (4) and rotate manual clutch lock lever (5) 180° counterclockwise to engage electromagnetic clutch.
4. Install floor plate (3) with four bolts (1) with captive lockwashers and four flat washers (2).
5. Start main engine (WP 0012 00) and operate hydraulics to perform mission.

Disengagement

1. Shut down main engine (WP 0019 00).
2. Remove four bolts (1) with captive lockwashers, four flat washers (2) and floor plate (3).
3. Pull manual clutch lock lever knob (4) and rotate manual clutch lock lever (5) 180° clockwise to disengage electromagnetic clutch.
4. Install floor plate (3) with four bolts (1) with captive lockwashers and four flat washers (2).
5. Notify unit maintenance.

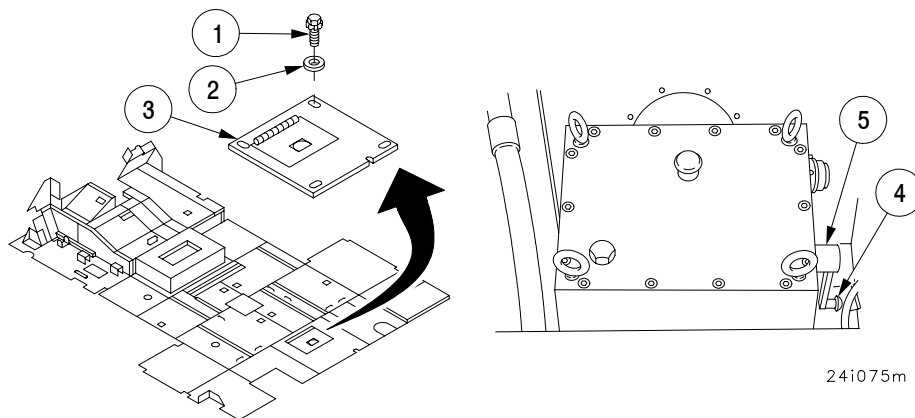

PREPARING HYDRAULIC SYSTEM FOR OPERATION - CONTINUED**0045 00****AUXILIARY HYDRAULIC SYSTEM**

1. Place the SYSTEM SELECTOR control lever (1) in the MAIN position.
2. Ensure that the PTO CLUTCH switch (2) is OFF.
3. Start the auxiliary power unit (WP 0053 00).
4. Allow system to warm up 5 minutes.
5. To operate main winch, hoist winch, auxiliary winch, boom, or spade in no load condition, move SYSTEM SELECTOR control lever (1) to AUX position then operate MAIN WINCH, HOIST WINCH, AUX WINCH, BOOM and BOOM SAFETY, or SPADE control levers.
6. To operate impact wrench or refuel/defuel, move SYSTEM SELECTOR control lever to REFUEL position then operate impact wrench (WP 0055 00) or refuel/defuel (WP 0054 00).

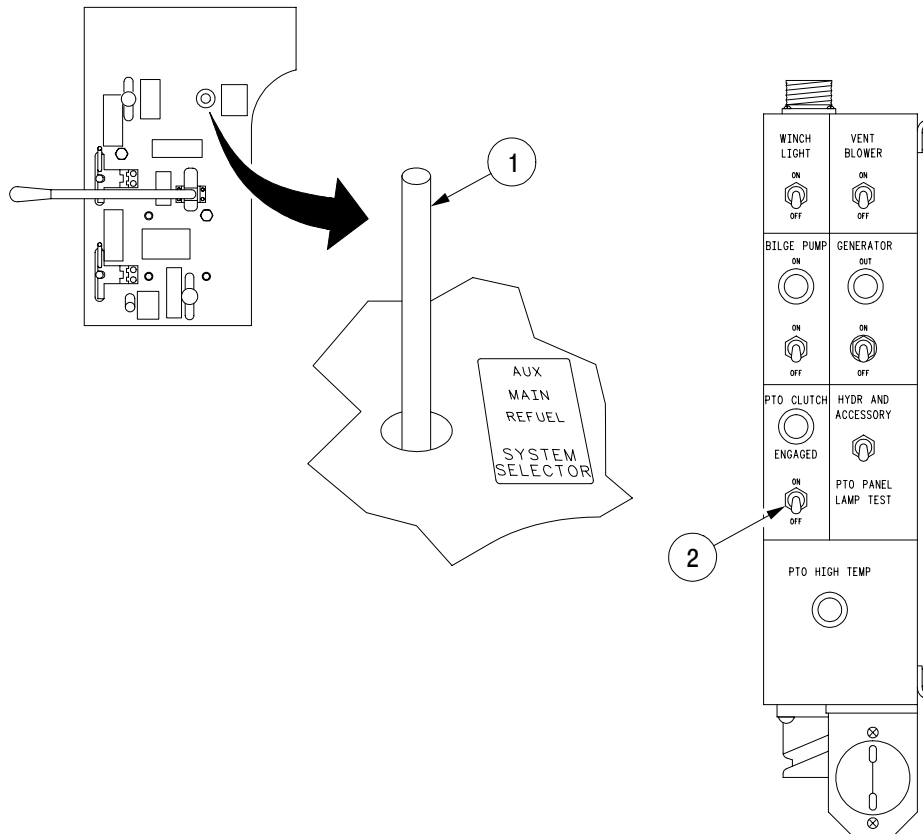

06i012ma

END OF TASK

OPERATE SPADE**0046 00****THIS WORK PACKAGE COVERS:**

Operate Spade

INITIAL SETUP:**References**

WP 0045 00

The spade is used only to stabilize vehicle when hoisting loads over 6 tons (5448 kg) without lockout blocks and during main winch operations. The spade can be operated by either main or auxiliary hydraulic systems. The controls are located in operator's area.

CAUTION

The auxiliary hydraulic system can be used to power spade only under no load conditions. Failure to comply may result in over loading hydraulic system and cause equipment damage.

1. Prepare hydraulic system for operation (WP 0045 00).
2. Move SPADE operating lever (1) to RAISE.
3. Push spade lock release button (2) and hold.
4. Move SPADE operating lever (1) to LOWER until spade clears spade lock and then release spade lock release button (2).
5. Move SPADE operating lever (1) to RAISE or LOWER for desired operation.

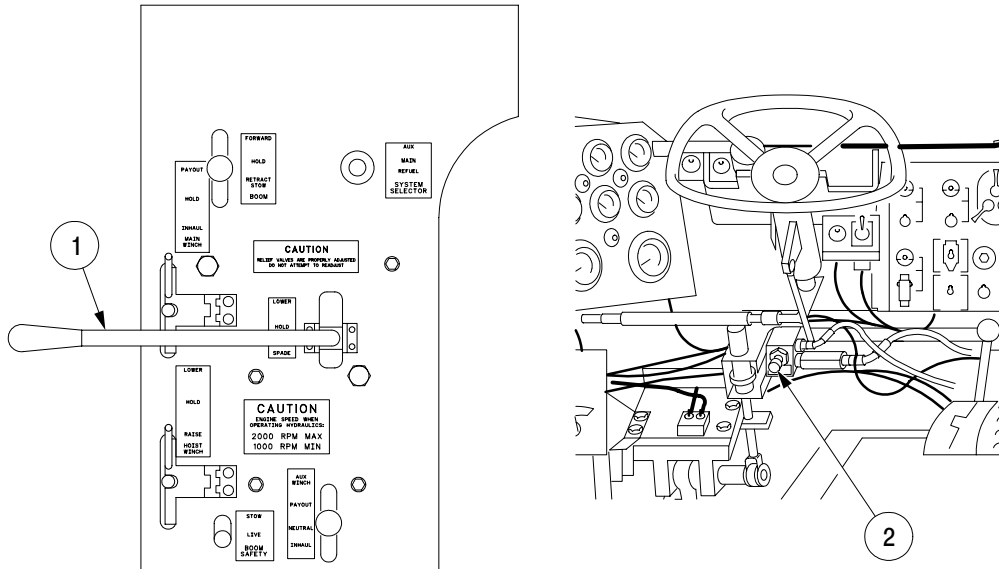

241079m

CAUTION

The spade may be used for light earth moving and leveling (dozing) for preparation for recovery only. Use only lower edge of spade to perform light earth moving. Do not use spade for dozing if ground is hard or frozen. Failure to comply may result in damage to the spade cylinders.

6. Lower spade until it touches ground.
7. Keep the SPADE operating lever (1) in the LOWER position and return engine speed to idle (825-875 rpm).
8. Shift transmission selector (3) to third gear.
9. Release brake and move vehicle forward slowly.
10. When vehicle stabilizes over spade, shift the SPADE operating lever (1) to HOLD.
11. Apply brakes and shift transmission selector (3) to park (P).
12. Increase engine speed to between 1,000 and 2000 rpm.
13. Continue with recovery operation.
14. Set engine speed to idle (825-875 rpm).
15. Shift transmission selector (3) to reverse (R).
16. Move SPADE operating lever (1) to RAISE and release brakes.
17. Move vehicle slowly in reverse to back off spade.
18. When spade leaves ground, apply brakes, shift transmission selector (3) to park (P).
19. Continue to raise spade until spade lock is engaged.

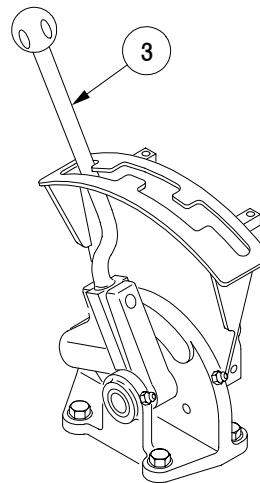
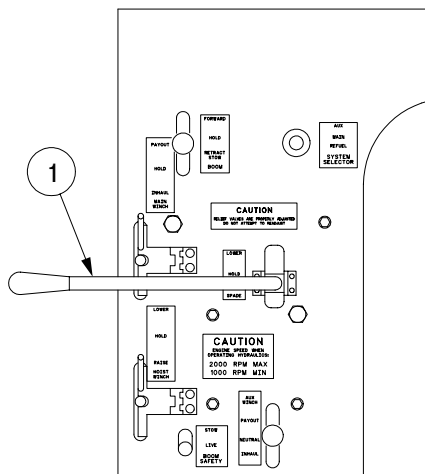

18i230m

END OF TASK

OPERATE BOOM**0047 00**

THIS WORK PACKAGE COVERS:

Rigging Boom, Raising Boom, Moving Boom Forward and Backward, Lowering Boom, Lockout Blocks

INITIAL SETUP:**Tools and special Tools**Socket wrench set (item 38, Table 2, WP 0133 00)
Lockout blocks (item 8, Table 2, WP 0133 00)**Personnel Required**

Three

Equipment Conditions

Vehicle parked and brakes locked; main engine shut down (WP 0019 00)

ReferencesWP 0029 00
WP 0045 00
WP 0046 00
WP 0048 00
WP 0133 00
WP 0019 00
WP 0106 00

The boom is powered by main hydraulic system under normal conditions. In an emergency the boom may be raised or lowered under no-load conditions using auxiliary hydraulic system. The boom controls are in operator's area.

WARNING

Do not stand on top of vehicle while boom is being raised or lowered. Failure to comply may result in boom impacting personnel causing injury or DEATH to personnel.

CAUTION

If powerpack is removed, and APU is non-operational, leave boom in full raised position. Do not attempt to lower boom; damage to boom, boom cylinders and hydraulic system could occur.

To avoid damage to the boom and hydraulic system, always keep boom in stowed position when not in use.

NOTE

In extreme or emergency cases, notify unit maintenance to ground hop APU and lower boom.

RIGGING BOOM

CAUTION

Read the following instructions carefully to keep from tangling the cable when rigging. Failure to comply may result in damage to equipment.

1. Disconnect straps (1) and secure out of the way.

WARNING

35-ton hook block weighs approximately 350 lbs (159 kg). Use suitable lifting device to lift or move. Failure to comply may result in injury to personnel.

2. Using suitable lifting device, position 35-ton hook block in hook block tray with lockwire (2) and fillister screw (3) facing up.

**WARNING**

3. Remove lockwire (2) and fillister screw (3) from 35-ton hook block (4). Discard lockwire.

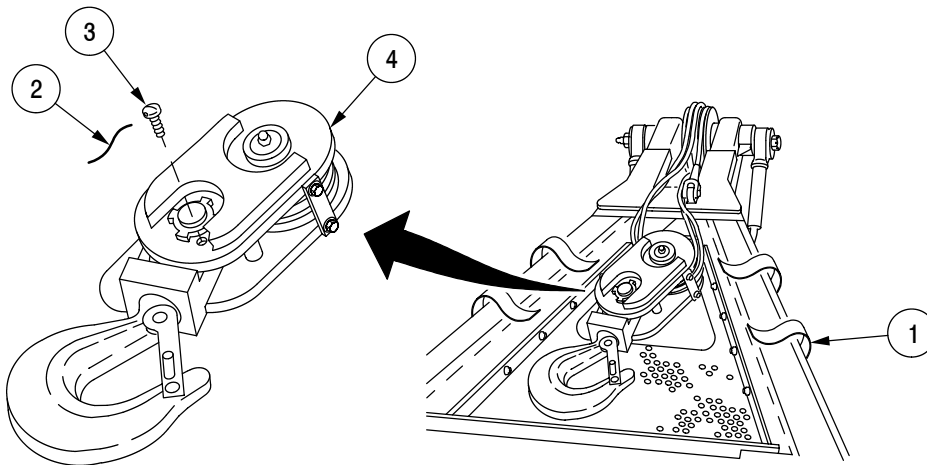

20i020md

OPERATE BOOM - CONTINUED

0047 00

RIGGING THE BOOM - CONTINUED

4. Unscrew and remove latchpin and nut assembly (5) and hook (6).
5. Remove four screws (7), four lockwashers (8), four flat washers (9), and two rope guard plates (10).
6. Remove four screws (11), four lockwashers (12), four flat washers (13), and two cable retainers (14).

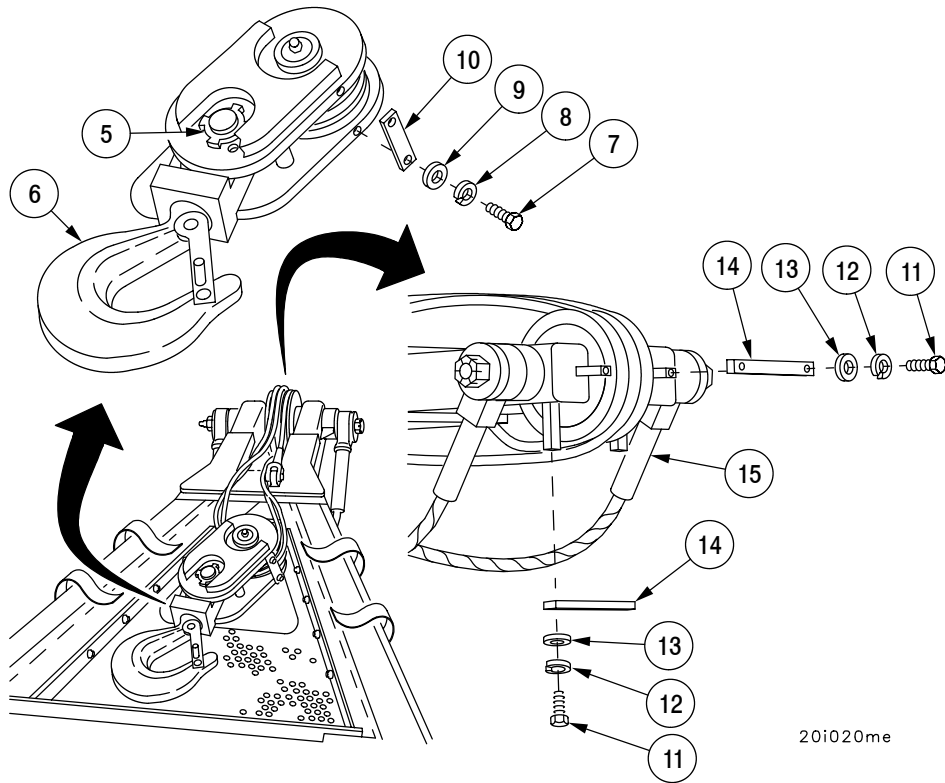

OPERATE BOOM - CONTINUED**0047 00****RIGGING BOOM - CONTINUED**

7. Open hoist winch cable access cover (WP 0029 00).

WARNING

Cable can become frayed or contain broken wires. Wear leather-palmed work gloves when handling cable. Frayed or broken wires can injure hands.

Never let cable slide through hands, even when wearing gloves. A broken wire could cut through glove and injure hand.

8. Have operator pay out hoist winch cable. Pass cable over top of the crew compartment and under the boom cross-members. Keep hoist winch cable between staylines (15).

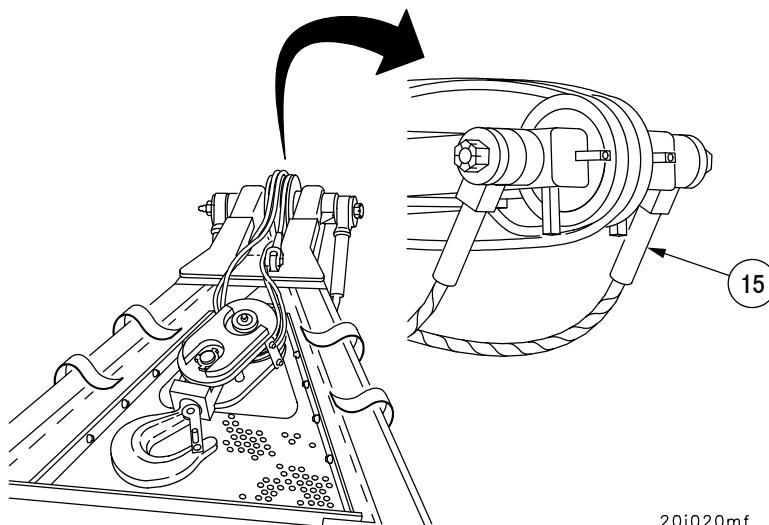

20i020mf

OPERATE BOOM - CONTINUED

0047 00

RIGGING BOOM - CONTINUED

9. Bring cable under and around outside (rotating) boom pulley (16).
10. Pull cable forward and lay it in upper pulley (17) of the 35-ton (31,780 kg) hook block (4) as illustrated.
11. Bring cable back over upper cross-member (18) and down under middle boom pulley (19).

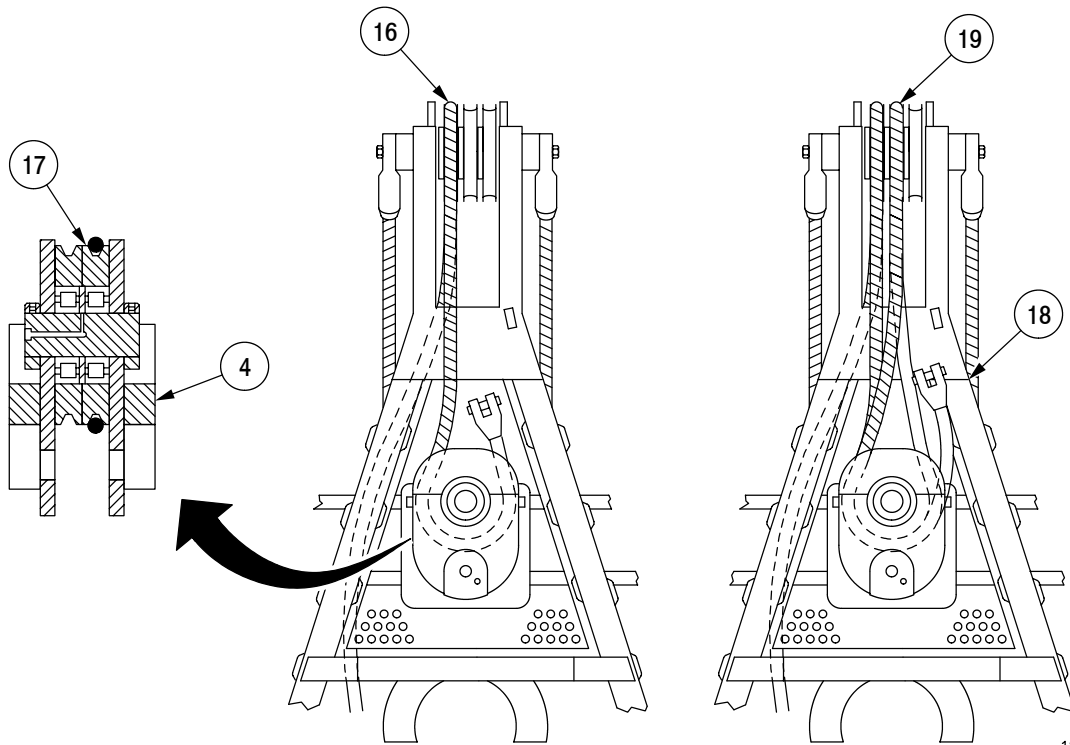

18i070me

OPERATE BOOM - CONTINUED

0047 00

RIGGING BOOM - CONTINUED

12. Bring cable forward, around middle boom pulley (19).
13. Bring cable forward and lay it in lower pulley (20) of the 35-ton (31,780 kg) hook block (4) as illustrated.
14. Bring cable back over upper cross-member (18), and under outside stationary pulley (21).

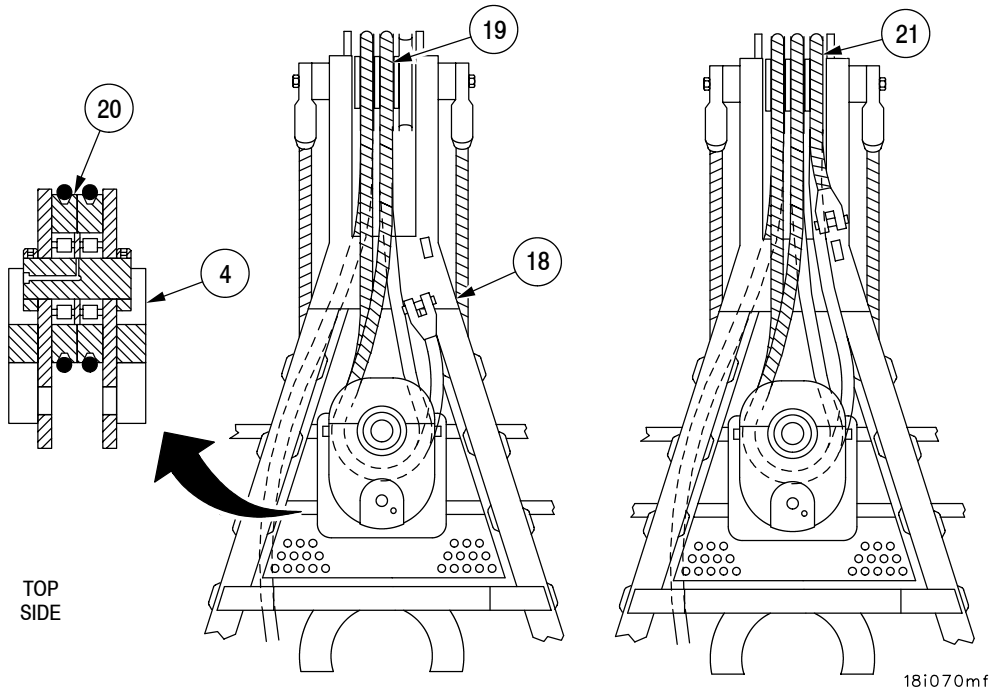

OPERATE BOOM - CONTINUED**0047 00****RIGGING BOOM - CONTINUED**

15. Bring cable forward, around outside stationary pulley (21).
16. Remove nut (22) and screw (23) or cotter pin (22) and headless pin (23) from hoist winch cable end.
17. Bring cable forward and secure it to cable lug (24) with screw (23) and nut (22) or headless pin (23) and cotter pin (22).

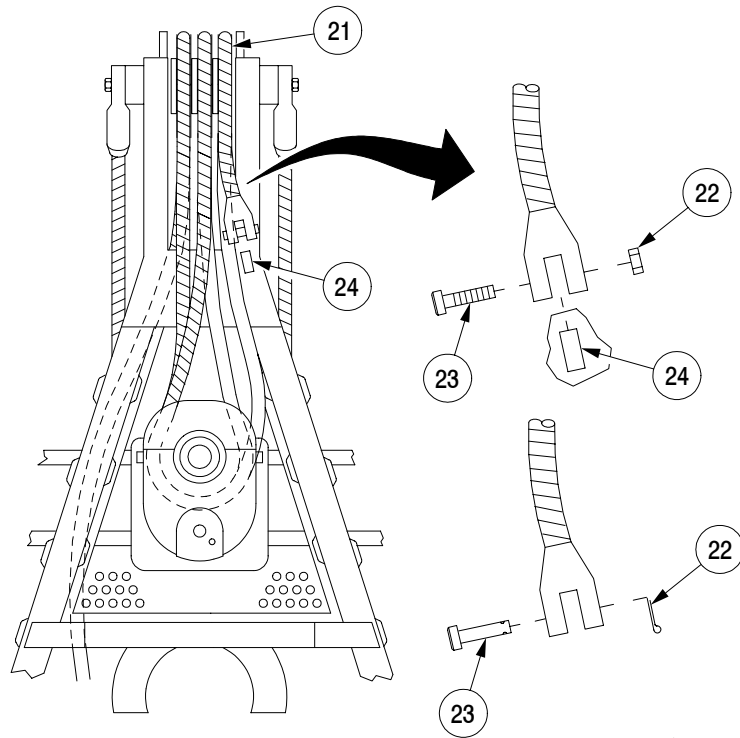

18i070mb

RIGGING BOOM - CONTINUED

18. Install two rope guard plates (10), four flat washers (9), four lockwashers (8), and four screws (7).

19. Install hook (6) and latchpin and nut assembly (5) in 35-ton (31,780 kg) hook block (4).



WARNING

20. Install fillister screw (3) and secure with new lockwire (2).

21. Install two cable retainers (14), four flat washers (13), four lockwashers (12), and four screws (11).

22. Secure 35-ton (31,780 kg) hook block (4) in boom tray (25) with straps (1) unless a hoist operation is to be done.

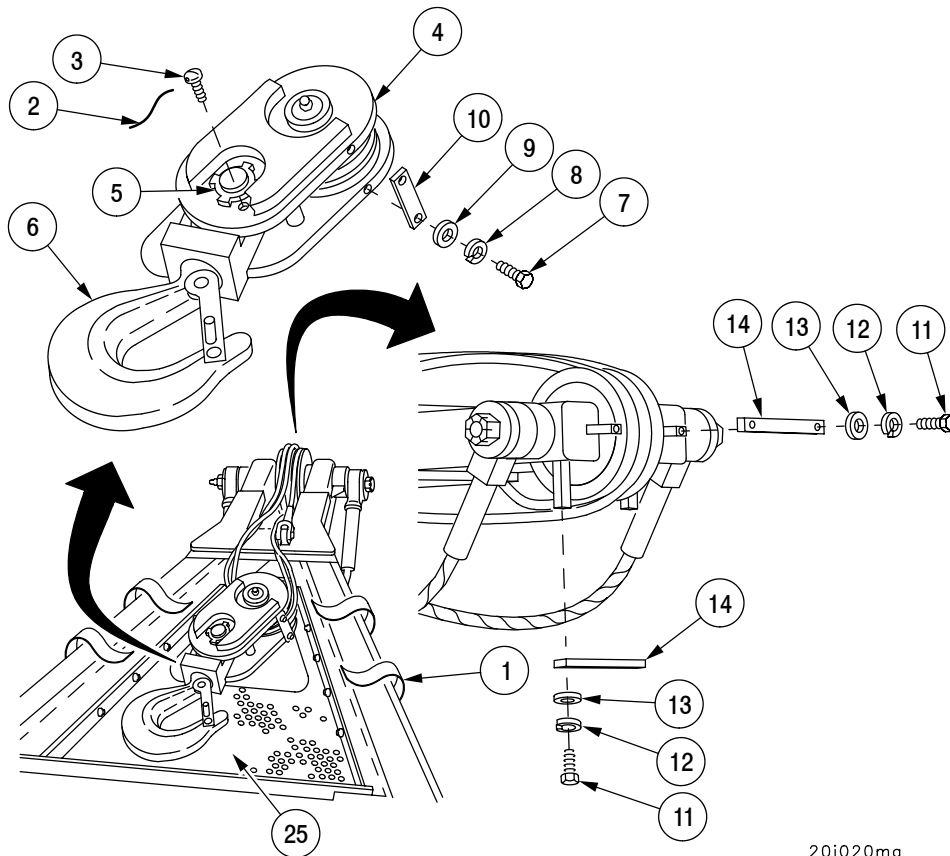

20i020mg

RAISING BOOM

WARNING

Do not stand on top of vehicle while boom is being raised or lowered. Failure to comply may result in the boom impacting personnel, causing injury or DEATH to personnel.

Prior to raising boom remove any loose objects from boom basket and ensure all hatches are closed. Failure to comply may result in loose objects falling on personnel standing below, causing injury or DEATH to personnel.

While raising boom, check that hoist winch, stayline cables and other equipment do not catch on deck door, hinges, and handles. Failure to comply may result in injury to personnel and/or damage to equipment.

1. Prepare main or auxiliary hydraulic system for operation (WP 0045 00).
2. Disconnect straps securing 35-ton hook block in tray.
3. Push in on boom latch (1) until it locks in open position.
4. Remove hoist winch cable (2) from cable stays (3) and J-hook (4) and open and release stayline cables (5) from securing clamps (6).
5. Verify tree shoe chains, hoist cable and stayline cables are free of engine deck door handles, oxygen bottle and vise.
6. Open hoist winch cable access door (WP 0029 00).

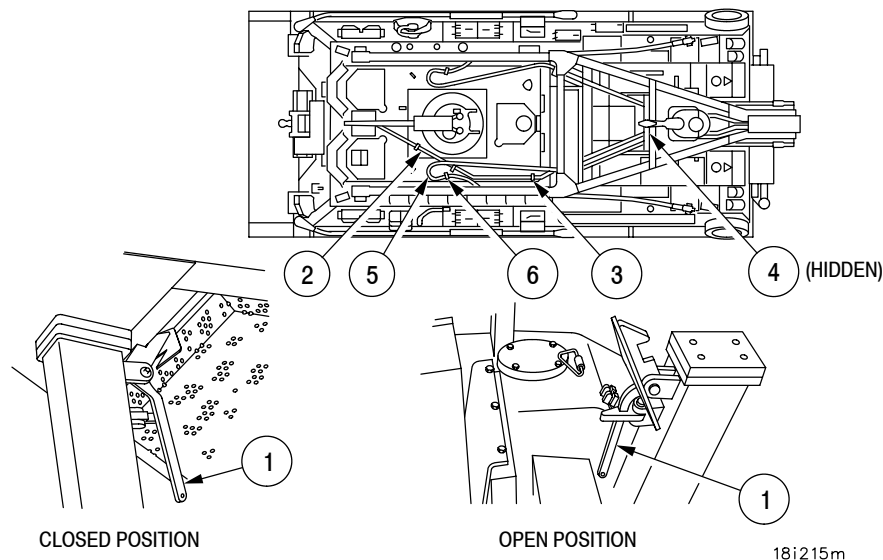

18i215m

OPERATE BOOM - CONTINUED**0047 00****MOVING BOOM FORWARD AND BACKWARD - CONTINUED****WARNING**

Do not stand on top of vehicle while raising or lowering the boom. Failure to comply may result in boom impacting personnel during operation, causing injury or DEATH to personnel.

Carry loads as near to four foot retraction as possible for safety and stability. Failure to comply may result in load swinging and impacting personnel causing injury or DEATH to personnel or damage to equipment.

Stabilize 6- to 25-ton (5,443 to 22,680 kg) loads against spade when moving. Failure to comply may result in load swinging and impacting personnel, causing injury or DEATH to personnel or damage to equipment.

CAUTION

Maximum lift for live Operate Boom is not to exceed 70,000 lbs (31,780 kg). Failure to comply may result in damage to equipment.

1. To move boom back from full-forward position, move BOOM operating lever (1) to RETRACT and hold until boom has reached desired position.

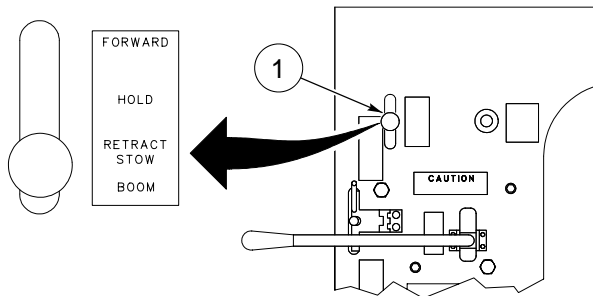

24i009gm

OPERATE BOOM - CONTINUED**0047 00****MOVING BOOM FORWARD AND BACKWARD - CONTINUED**

- To move boom forward, move BOOM operating lever (1) to FORWARD and hold until boom has reached desired position.

NOTE

If the boom is brought all the way back 4 feet (122 cm), both the BOOM SAFETY and BOOM operating control levers must be used to start the boom forward again.

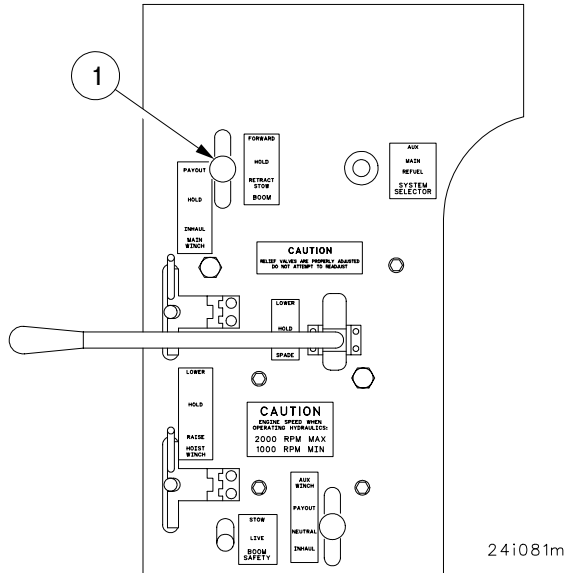
**LOWERING BOOM****WARNING**

Do not stand on top of vehicle while raising or lowering the boom. Failure to comply may result in boom impacting personnel during operation, causing injury or DEATH to personnel.

Ensure all hatches are closed. Failure to comply may result in injury or DEATH to personnel.

OPERATE BOOM - CONTINUED**0047 00****LOWERING BOOM - CONTINUED**

1. Before lowering boom, raise the 35-ton (31,780 kg) hook block so it will lay in boom tray when boom is lowered (WP 0048 00).

WARNING

Do not keep boom in full raised position for an extended period of time. Failure of the hydraulic system could occur, allowing the boom to freefall when lowered, causing injury or DEATH to personnel.

2. If boom has been in raised position for an extended period of time (days or weeks) perform following steps before lowering boom.
 - Move BOOM operating lever (2) to FORWARD position and hold for approximately five minutes. This allows system to fill with oil and eliminate any air pockets.
 - Use BOOM operating lever (2) to move boom backward and forward several times in live boom area. This will assure that all air pockets have been eliminated and that boom will operate smoothly.
3. Move BOOM SAFETY control lever (1) to STOW position and hold.
4. Move BOOM operating lever (2) to RETRACT and hold.
5. Continue to lower boom until it is about 1 ft from the engine deck, then release BOOM operating lever (2). Release BOOM SAFETY operating lever (1).
6. Verify that stayline and hoist winch cables are safely stowed.
7. Continue lowering boom, using both levers as required until boom is in full-down position against travel lock, then release BOOM operating lever (2) and then release BOOM SAFETY operating lever (1).

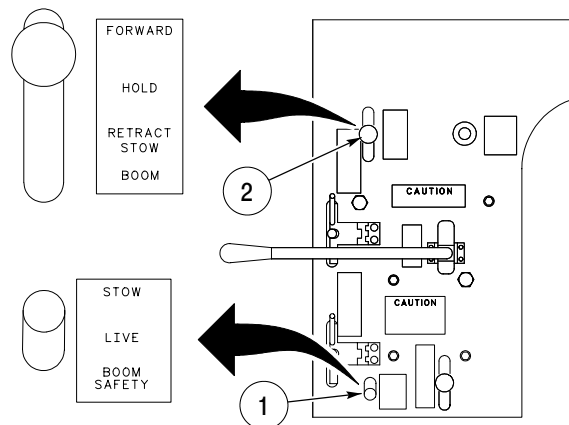

LOWERING BOOM - CONTINUED

CAUTION

Always keep boom in stowed (travel lock) position when not in use. Failure may result in damage to boom or hydraulic system due to impact or vibration while traveling on uneven terrain.

8. Release catch on boom latch (3) and lock boom in stowed position.
9. Secure hook block in boom tray with straps.

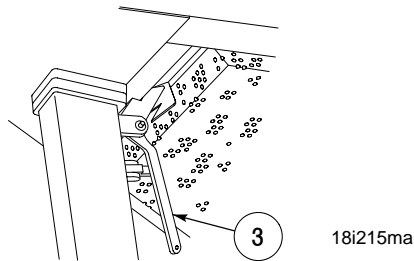

10. Close hoist winch cable access door (WP 0029 00).

LOCKOUT BLOCKS

Lockout blocks are used when lifting and carrying loads from 12,001 to 50,000 pounds (5,443 to 22,680 kg). Lockout blocks prevent damage to the front suspension system.

Installing lockout blocks

1. Raise front of vehicle by driving up on spade (WP 0046 00).
2. Lock brakes and shut off engine.
3. Open side armor skirt panel #2 (WP 0106 00).
4. Remove lock screws (1), lockwashers (2), and flat washers (3) from lockout block spacer (4) and bumper stop assembly (5).
5. Loosen screw (6) securing lockout block spacer (4) to bumper stop assembly (5). Swing lockout block spacer (4) 90° to inside, secure lockout block spacer (4) in 90° position.
6. Slide lockout block (7) on top of inside spindle (8) of front of roadwheel arm (9).

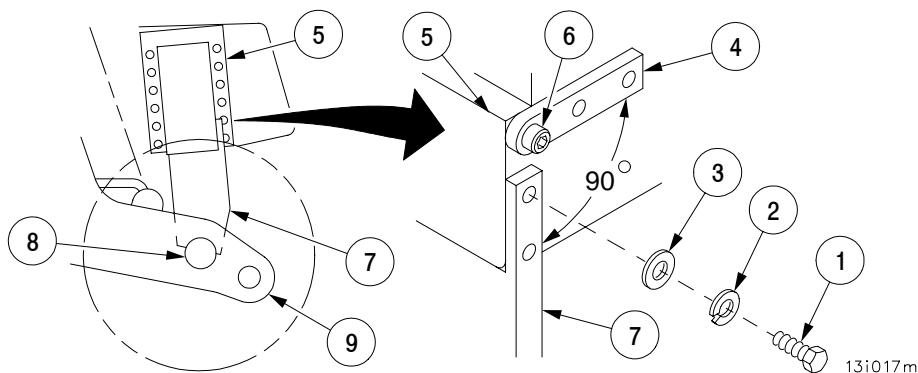

LOCKOUT BLOCKS - CONTINUED**Installing lockout blocks - Continued**

7. Install lock screws (1), lockwashers (2), and flat washers (3) through lockout block (7) and into bumper stop assembly (5).
8. Close side armor skirt #2 (WP 0106 00).
9. Repeat procedures for other side.
10. Start main engine and back off spade (WP 0046 00).
11. Ensure that blocks line up with inside spindle (8).

Carrying load with lockout blocks installed**WARNING**

Carry loads as near to four foot retraction as possible for safety and stability. Failure to comply may result in load swinging and impacting personnel causing injury or DEATH to personnel or damage to equipment.

Stabilize 6- to 25-ton (5,443 to 22,680 kg) loads against spade when moving. Failure to comply may result in load swinging and impacting personnel, causing injury or DEATH to personnel or damage to equipment.

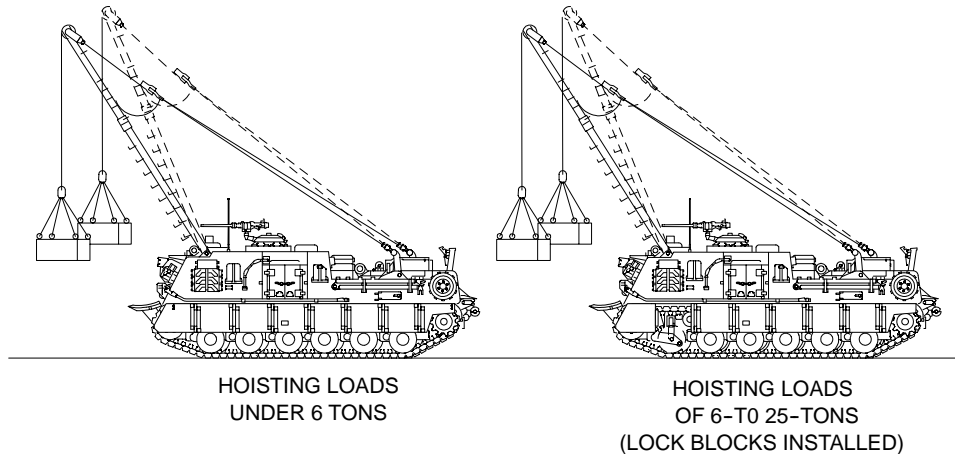

18i076m

LOCKOUT BLOCKS - CONTINUED

Carrying load with lockout blocks installed - Continued

CAUTION

Do not exceed maximum speeds. Exceeding maximum speeds could cause damage to the equipment.

1. Maximum vehicle speed carrying 12,001 to 30,000 lbs (5,443 to 13,620 kg) is 3 mph (5 kmph).
2. Maximum vehicle speed carrying 30,001 to 50,000 lbs (13,620 to 22,680 kg) is 2 mph (3 kmph).

Removing lockout blocks

1. Raise front of vehicle by driving up on spade (WP 0046 00).
2. Lock brakes and shut off engine.
3. Open side armor skirt panel #2 (WP 0106 00).
4. Remove lock screws (1), lockwashers (2) and flat washers (3) from lockout blocks (7) and bumper stop assembly (5).
5. Remove lockout block (7) from bumper stop assembly (5).
6. Loosen screw (6) securing lockout block spacer (4) to bumper stop assembly (5). Place lockout block spacer (4) in vertical position.
7. Install lock screws (1), lockwashers (2) and flat washers (3) through lockout block spacer (4) and into bumper stop assembly (5). Tighten screw (6) securing lockout block spacer (4).
8. Close and secure side armor skirt panel #2 (WP 0106 00).
9. Start main engine and back vehicle off spade (WP 0046 00).

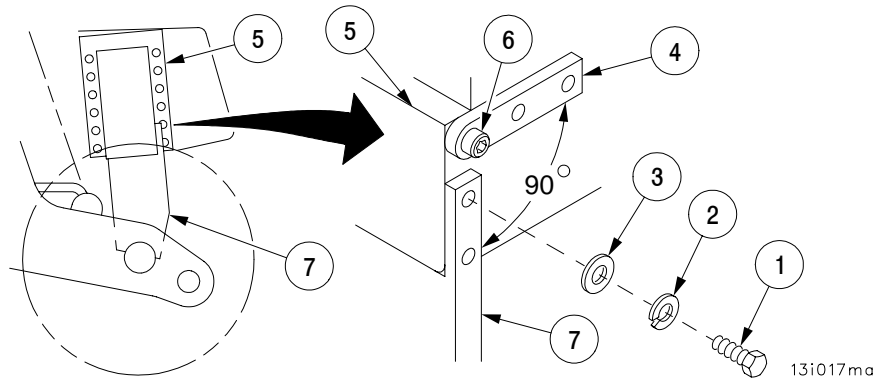

END OF TASK

OPERATE HOIST WINCH

0048 00

THIS WORK PACKAGE COVERS:

Operate Hoist Winch

INITIAL SETUP:

References

WP 0046 00

The hoist winch is used with boom and 35-ton (31,780 kg) hook block to lift loads up to 70,000 pounds (31,780 kg). The controls for hoist winch are in operator's area.

WARNING

Ensure all safety pins and bolts are in place and secure prior to lifting. Failure to comply may result in injury or DEATH to personnel.

Do not lift loads at an angle of more than three degrees from center. Failure to comply may result in injury to personnel or damage to equipment.

Never grasp cable close to stationary objects. Sudden movement of cable could injure hands.

1. Align boom over center of load with recovery vehicle in level position.
2. Spade lowered (WP 0046 00).

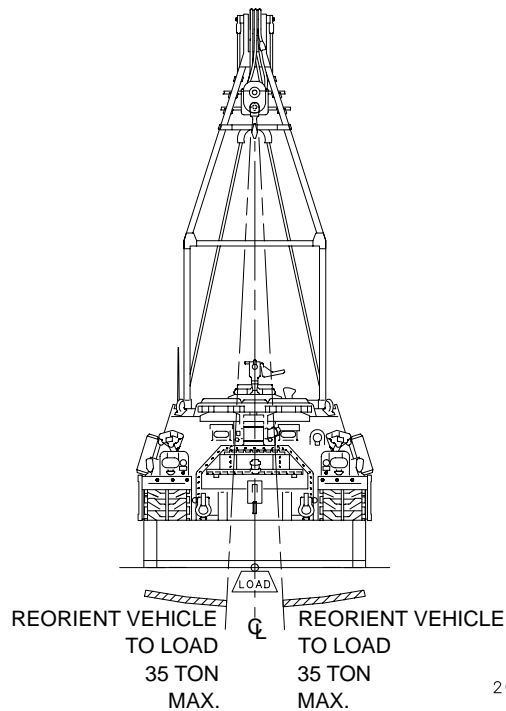

20i021ma

OPERATE HOIST WINCH - CONTINUED

0048 00

3. Raise hoist winch lever cover and move HOIST WINCH operating lever (1) to LOWER position to connect load.

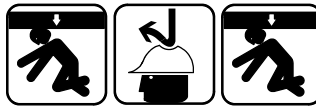

WARNING

WARNING

If one or more roadwheels lose ground contact, lower load immediately. Load is in excess of 75,000 lbs (34,050 kg) and exceeds lifting limits of the vehicle. Failure to comply may result in injury to personnel or damage to equipment.

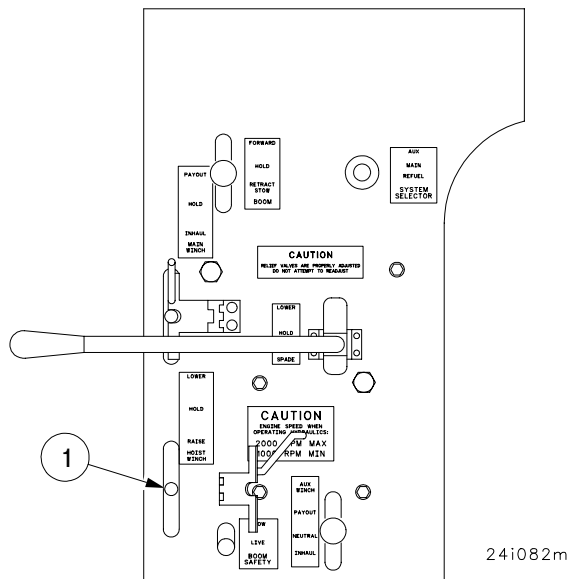

24i082m

WARNING

Do not exceed 70,000-lbs (31,780 kg) lift capacity of hoist winch. Failure to comply may result in failure of the hoist winch causing the load to free fall resulting in injury or DEATH to personnel or damage to equipment.

Never use hoist winch with less than five wraps on the drum. Failure to comply may result in hoist winch cable coming loose from drum causing injury to personnel or damage to equipment.

CAUTION

Use lockout blocks for load between 12,001 and 50,000 lbs (5,443 to 22,680 kg) and spade for load between 50,001 and 70,000 lbs (22,680 to 31,780 kg). Failure to comply may result in over compression of the suspension causing damage to equipment.

Minimum engine speed for winching operation is 1,000 rpm. Engine speed for normal operating conditions is 1800 rpm. Engine speed should be increased to a maximum of 2000 rpm for hot weather or continuous operation. Operating outside limits may result in damage to equipment.

4. Move HOIST WINCH operating lever (1) to RAISE to hoist load.
5. Release the HOIST WINCH operating lever (1) to HOLD load in that position.
6. Move HOIST WINCH operating lever (1) to LOWER position to lower load.
7. Close hoist winch lever cover.

END OF TASK

OPERATE AUXILIARY WINCH**0049 00****THIS WORK PACKAGE COVERS:**

Operate Auxiliary Winch

INITIAL SETUP:**Personnel Required**

Three

References

WP 0045 00

The auxiliary winch is used to pay out main winch cable because of its weight. The auxiliary winch is capable of a 6,000-lb (2,722 kg) single line pull. The auxiliary winch is normally powered by main hydraulic system but can be powered by auxiliary hydraulic system under a no-load emergency situation. The controls for auxiliary winch are in operator's area.

1. Prepare main or auxiliary hydraulic system for operation (WP 0045 00).

WARNING

Cable can become frayed or contain broken wires. Wear leather-palmed work gloves when handling cable. Frayed or broken wires can injure hands.

Never grasp cable near stationary objects. Sudden movement of cable could injure hands.

Never let cable slide through hands, even when wearing gloves. A broken wire could cut through glove and injure hand.

A minimum of five wraps should remain on winch drum at all times. Failure to comply may result in auxiliary winch cable coming loose from drum which may cause injury or DEATH to personnel or damage to equipment.

CAUTION

Maintain tension on cable during PAYOUT and INHAUL. This will allow level winding and prevent damage to equipment.

2. Move AUX WINCH operating lever (1) to PAYOUT to pay out cable.

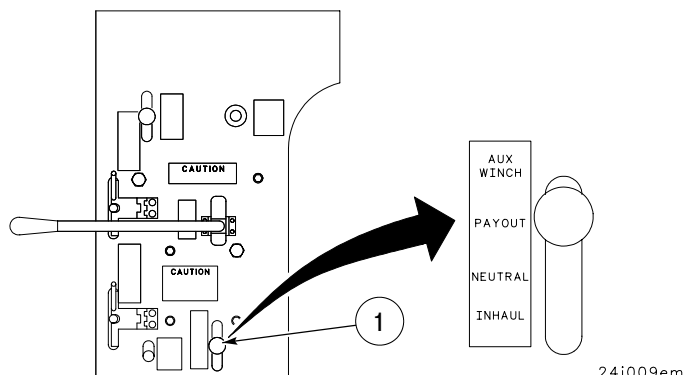

CAUTION

Minimum engine speed for winching operations is 1,000 rpm. Engine speed for normal operating conditions is 1,800 rpm. Engine speed should be increased to a maximum of 2000 rpm for hot weather or continuous operation. Failure to comply may result in damage to equipment.

Maintain tension on cable during PAYOUT and INHAUL. This will allow level winding and prevent damage to equipment.

NOTE

Auxiliary winch will not be used for hoisting

3. Move AUX WINCH operating lever (1) to INHAUL to inhaul cable.

NOTE

The auxiliary winch operating lever has a detent in the INHAUL position for hands-off operation.

The auxiliary winch may creep in the pay-out direction when lever is in "neutral" position. This is a normal characteristic of the auxiliary winch.

END OF TASK

OPERATE MAIN WINCH

0050 00**THIS WORK PACKAGE COVERS:**Operate Main Winch

INITIAL SETUP:**Personnel Required**

Three

References

WP 0045 00

WP 0104 00

The main winch is used to recover disabled vehicles. The main winch is capable of 140,000-lb (63,560 kg) single line pull. The main winch is powered by main hydraulic system but can be powered by auxiliary hydraulic system under a no-load emergency situation. The controls for the main winch are located in operator's area.

1. Prepare main hydraulic system for operation (WP 0045 00).

WARNING

Cable can become frayed or contain broken wires. Wear leather-palmed work gloves when handling cable. Frayed or broken wires can injure hands.

Never let cable slide through hands, even when wearing gloves. A broken wire could cut through glove and injure hand.

A minimum of four wraps should remain on winch drum at all times. Failure to comply may result in main winch cable coming loose from drum resulting in injury or DEATH to personnel or damage to equipment.

WARNING

Never grasp cable near stationary objects. Sudden movement of cable could injure hands.

CAUTION

Minimum engine speed for winching is 1,000 rpm. Engine speed for normal operating conditions is 1,800 rpm. Engine speed should be increased to a maximum of 2000 rpm for hot weather or continuous operation. Failure to comply may result in failure of the main winch or damage to equipment.

Never pay out main winch cable without tension on it. Use the auxiliary winch. Failure to comply may result in main winch malfunction and possible damage to equipment.

Start pay out of main winch cable slowly. Fast initial pay out can cause the cable to unspool. Failure to comply may result in damage to the main winch.

NOTE

If birdnesting occurs during payout/inhaul of main winch cable, if cable gets kinked or excessive mud/debris or if foreign objects come in contact with cable or shut off switches, winch will automatically shut down. WINCH DRUM MALFUNCTION indicator and SYSTEM WARNING indicator will light and warning horn will sound.

2. Raise main winch lever cover.
3. Move main winch operating lever (1) to PAYOUT.
4. Attach main winch to load.
5. Move MAIN WINCH operating lever (1) to INHAUL to recover disabled vehicle. Keep operating lever (1) to INHAUL until disabled vehicle is as close as possible to main winch. This will keep tension on main winch cable during inhaul.
6. Release main winch operating lever (1).
7. If a malfunction occurs during main winch operation, perform the following:
 - Release main winch operating lever (1).
 - Troubleshoot malfunction (WP 0104 00).

CAUTION

Do not use WINCH OVERRIDE switch (2) to complete mission if main winch automatically shuts down. WINCH OVERRIDE switch (2) should only be used after making sure there is no damage to the main winch, levelwind system, or main winch cable and then only to correct the fault. Failure to comply may result in failure of the main winch or damage to equipment.

Once malfunction is cleared, start the main engine if it is not already running.

Continue with recovery operations.

8. After recovery operations:
 - If necessary, payout main winch cable.
 - Maintain tension on cable.

NOTE

Ensure main winch cable wraps evenly on drum.

- Inhaul main winch cable.
9. Close main winch lever cover.

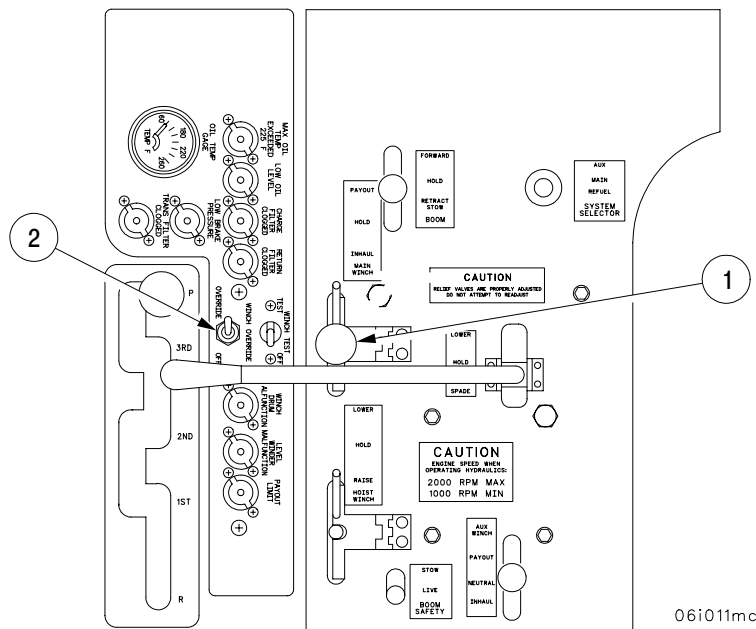

END OF TASK

VEHICLE RECOVERY OPERATIONS**0051 00****THIS WORK PACKAGE COVERS:**

Pay out main winch cable for single line recovery using auxiliary winch, Pay out main winch cable for double line recovery using auxiliary winch, Pay out main winch cable by backtracking from disabled vehicle.

INITIAL SETUP:**Tools and special Tools**

6.5-ton snatch block (item 6, Table 1, WP 0133 00)
 12-1/2-ton shackles (AR) (item 39, Table 1, WP 0133 00)
 18-ton shackles (AR) (item 40, Table 1, WP 0133 00)
 50-ton shackles (AR) (item 41, Table 1, WP 0133 00)
 2" diameter, high strength anchor shackle (AR) (item 42, Table 1, WP 0133 00)
 Tow cables (AR) (item 7, Table 1, WP 0133 00)
 140-ton snatch block (item 5, Table 1, WP 0133 00)

Personnel Required

Three

References

WP 0046 00
 WP 0104 00
 WP 0133 00
 WP 0049 00
 FM 9-43-2

WARNING

All personnel will stay clear (at least double the length of cable used) during winching operation. Cable could snap resulting in injury or DEATH to personnel.

CAUTION

Do not exceed the main winch capacity of 140,000-pound (63,560 kg) single line pull or 280,000-pound (127,120 kg) double line pull. Failure to comply may result in damage to main winch.

Minimum engine speed for winching is 1,000 rpm. Engine speed for normal operating conditions is 1,800 rpm. Engine should be increased to a maximum of 2,000 rpm for hot weather or continuous operation. Operating outside of limits may result in damage to equipment.

Start pay out of main winch cable slowly. Fast initial payout can cause the cable to unspool. Failure to comply may result in damage to the main winch.

1. Refer to FM 9-43-2, Vehicle Recovery Operations, to calculate the recovery weight of the disabled vehicle.
2. Based on the results of the recovery weight calculations, deploy the main winch cable using one of the following procedures in this work package.
 - Pay out main winch cable for single line recovery using auxiliary winch.
 - Pay out main winch cable for double line recovery using auxiliary winch.
 - Pay out main winch cable by backtracking from disabled vehicle.

PAY OUT MAIN WINCH CABLE FOR SINGLE LINE RECOVERY USING AUXILIARY WINCH**NOTE**

The M88A2 must be pointed directly at the disabled vehicle to ensure small fleet angles and proper auxiliary winch spooling. Refer to WP 0104 00 for illustration of fleet angle.

1. Prepare auxiliary winch for operation (WP 0049 00).
2. Position spade to stabilize M88A2 (WP 0046 00).

VEHICLE RECOVERY OPERATIONS - CONTINUED**0051 00****PAY OUT MAIN WINCH CABLE FOR SINGLE LINE RECOVERY USING AUXILIARY WINCH - CONTINUED**

3. Attach 6.5-ton snatch block to tow lug of disabled vehicle using a shackle (items 39 through 42, Table 1, WP 0133 00).

WARNING

Cable can become frayed or contain broken wires. Wear leather-palmed work gloves when handling cable. Frayed or broken wires can injure hands.

Never let cable slide through hands, even when wearing gloves. A broken wire could cut through glove and injure hand.

4. Move AUX WINCH operating lever (1) to PAYOUT position, payout auxiliary winch cable to disabled vehicle keeping tension on cable.
5. Feed auxiliary winch cable through 6.5-ton snatch block on disabled vehicle, back to the front of the M88A2 and remove nut and bolt (or headless pin and cotter pin) from main winch cable and secure auxiliary winch cable to main winch cable using bolt and nut (or headless pin and cotter pin).

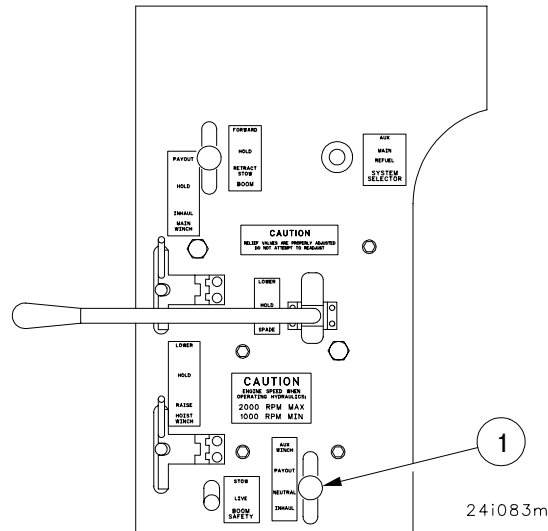

6. Increase engine speed to 1800 rpm.

PAY OUT MAIN WINCH CABLE FOR SINGLE LINE RECOVERY USING AUXILIARY WINCH - CONTINUED

WARNING

Do not move both the AUX WINCH and MAIN WINCH operating levers to INHAUL at the same time. This may result in the auxiliary winch cable snapping which may result in injury or DEATH to personnel.

7. Slowly move AUX WINCH operating lever (1) to INHAUL to take slack out of cables, then lock it in INHAUL detent position.

CAUTION

Start pay out of main winch cable slowly. Fast initial pay out can cause the cable to unspool. Failure to comply may result in damage to the main winch.

8. Raise main winch lever cover and move the MAIN WINCH operating lever (2) to PAYOUT.
9. Maintain tension on main winch cable all the way out to disabled vehicle by varying main winch speed.
10. Return MAIN WINCH lever (2) to neutral then return AUX WINCH operating lever (1) to neutral position when main winch cable has reached disabled vehicle.
11. Move AUX WINCH operating lever (1) slowly to PAYOUT to release tension on cables.
12. Remove auxiliary winch cable from main winch cable and 6.5-ton snatch block.
13. Remove 6.5-ton snatch block from disabled vehicle.

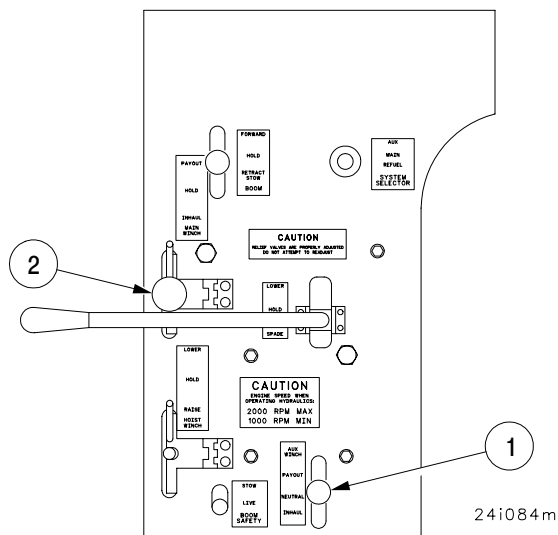

VEHICLE RECOVERY OPERATIONS - CONTINUED**0051 00****PAY OUT MAIN WINCH CABLE FOR SINGLE LINE RECOVERY USING AUXILIARY WINCH - CONTINUED****CAUTION**

Use of M88A2 tow cables as a sling leg on other than M88A2 will affect included angle of sling leg force calculation.

14. Connect disabled vehicles towing cables to each towing lug using disabled vehicles towing hooks. If disabled vehicles towing cables are not available, use M88A2 tow cables attaching them with 18-ton shackles to M2/M3 Family of Vehicles (FOV) or 50-ton shackles to connect to M1 FOV.
15. Attach main winch cable to tow cable sling legs using two 18-ton shackles and one 50-ton shackle.
16. Move AUX WINCH operating lever (1) to INHAUL and retrieve auxiliary winch cable keeping tension on cable.
17. Move MAIN WINCH operating lever (2) to INHAUL to recover disabled vehicle. Keep MAIN WINCH operating lever (2) to INHAUL until disabled vehicle is as close as possible to main winch. This will keep tension on main winch cable during inhaul.
18. Release MAIN WINCH operating lever (2).

PAY OUT MAIN WINCH CABLE FOR DOUBLE LINE RECOVERY USING AUXILIARY WINCH CABLE**NOTE**

The M88A2 must be pointed directly at the disabled vehicle to assure small fleet angles and proper auxiliary winch spooling. Refer to WP 0104 00 for illustration of fleet angle.

1. Prepare auxiliary winch for operation (WP 0049 00).
2. Lower spade to stabilize M88A2 (WP 0046 00).
3. Attach 6.5-ton snatch block to tow lug of disabled vehicle using a shackle (items 39 through 42, Table 1, WP 0133 00).

VEHICLE RECOVERY OPERATIONS - CONTINUED**0051 00****PAY OUT MAIN WINCH CABLE FOR DOUBLE LINE RECOVERY USING AUXILIARY WINCH CABLE
- CONTINUED****WARNING**

Wire rope can become frayed or contain broken wires. Wear leather-palmed work gloves when handling wire rope. Frayed or broken wires can injure hands.

Never let wire rope slide through hands, even when wearing gloves. A broken wire could cut through glove and injure hand.

4. Move AUX WINCH operating lever (1) to PAYOUT position.
5. Feed auxiliary winch cable through 6.5-ton snatch block on disabled vehicle, back to the front of the M88A2 and connect it to main winch cable.

WARNING

Do not move both the AUX WINCH and MAIN WINCH operating levers to INHAUL at the same time. This may result in the auxiliary winch cable snapping which may result in injury or DEATH to personnel.

6. Slowly move AUX WINCH operating lever (1) to INHAUL to take slack out of cable, then lock it in INHAUL detent position.

CAUTION

Start pay out of main winch cable slowly. Fast initial pay out can cause the cable to unspool. Failure to comply may result in damage to the main winch.

7. Raise main winch lever cover and move the MAIN WINCH operating lever (2) to PAYOUT.
8. While maintaining tension, pay out 25 ft (8 m) of main winch cable then return MAIN WINCH operating lever (2) to neutral position and payout AUX WINCH operating lever (1) until main winch cable lays on ground.

VEHICLE RECOVERY OPERATIONS - CONTINUED**0051 00****PAY OUT MAIN WINCH CABLE FOR DOUBLE LINE RECOVERY USING AUXILIARY WINCH CABLE
- CONTINUED****WARNING**

140-ton (127,120 kg) snatch block weighs 220 lbs (99.88 Kg). Use auxiliary boom to stow and unstow. Use three people when lifting or moving. Do not lift above waist. Failure to comply may result in injury to personnel.

9. Connect 140-ton (127,120 kg) snatch block to main winch cable by removing pin and shackle from 140-ton snatch block and placing main winch cable in pulley of 140-ton snatch block and installing shackle and pin.
10. Disconnect auxiliary winch cable from main winch cable.
11. Connect main winch cable to M88A2 winch lug with shackle and locking pin.

WARNING

Do not move both the AUX WINCH and MAIN WINCH operating levers to INHAUL at the same time. This may result in the auxiliary winch cable snapping which may result in injury or DEATH to personnel.

12. Attach auxiliary winch cable to 140-ton (127,120 kg) snatch block using shackle.
13. Slowly move AUX WINCH operating lever (1) to INHAUL to take slack out of cables, then lock it in the INHAUL detent position.

CAUTION

Start pay out of main winch cable slowly. Fast initial pay out can cause the cable to unspool. Failure to comply may result in damage to the main winch.

14. Move MAIN WINCH operating lever (2) to PAYOUT.
15. Maintain tension on main winch cable all the way out to the disabled vehicle by varying main winch speed.
16. Return both operating levers to neutral position when 140-ton (127,120 kg) snatch block reaches disabled vehicle.

VEHICLE RECOVERY OPERATIONS - CONTINUED**0051 00****PAY OUT MAIN WINCH CABLE FOR DOUBLE LINE RECOVERY USING AUXILIARY WINCH CABLE - CONTINUED**

17. Move AUX WINCH operating lever to PAYOUT to release tension on cables.
18. Disconnect auxiliary winch cable from 140-ton (127,120 kg) snatch block by removing shackle.

CAUTION

Use of M88A2 tow cables as a sling leg on other than M88A2 will affect included angle of sling leg force calculation.

19. Connect disabled vehicles towing cables to each towing lug using disabled vehicles towing hooks. If disabled vehicles towing cables are not available, use M88A2 tow cables, attaching them with 18-ton shackles to M2/M3 Family of Vehicles (FOV) or 50-ton shackles to connect to M1 FOV.

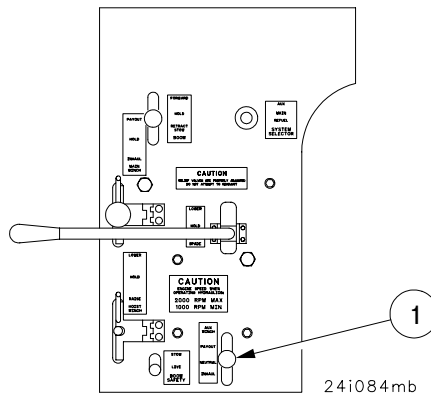

20. Connect 140-ton snatch block to tow cable sling legs using two 50-ton shackles and two 18-ton shackles. Attach one 50-ton shackle to 140-ton snatch block ensuring shackle pin (50-ton) is toward disabled vehicle. Attach second (50-ton) shackle to first 50-ton shackle (pin against pin). Using two 18-ton shackles attach each tow cable to second 50-ton shackle. This provides a winch point along center line of disabled vehicle for a straight line pull back to the M88A2.
21. Move AUX WINCH operating lever (1) to INHAUL and retrieve auxiliary winch cable keeping tension on cable.

VEHICLE RECOVERY OPERATIONS - CONTINUED**0051 00****PAY OUT MAIN WINCH CABLE FOR DOUBLE LINE RECOVERY USING AUXILIARY WINCH CABLE - CONTINUED**

22. Move MAIN WINCH operating lever (2) to INHAUL to recover disabled vehicle. Keep MAIN WINCH operating lever (2) to INHAUL until disabled vehicle is as close as possible to main winch. This will keep tension on main winch cable during inhaul.
23. Release MAIN WINCH operating lever (2).

PAY OUT MAIN WINCH CABLE BY BACKTRACKING FROM DISABLED VEHICLE

1. Release spade lock and lower spade (WP 0046 00) and establish/excavate the spade emplacement location prior to moving to disabled vehicle.
2. Move M88A2 to disabled vehicle.

CAUTION

Use of M88A2 tow cables as a sling leg on other than M88A2 will affect included angle of sling leg force calculation.

3. Connect disabled vehicles towing cables to each towing lug using disabled vehicles towing hooks. If disabled vehicles towing cables are not available, use M88A2 tow cables, attaching them with 18-ton shackles to M2/M3 Family of Vehicles (FOV) or 50-ton shackles to connect to M1 FOV.

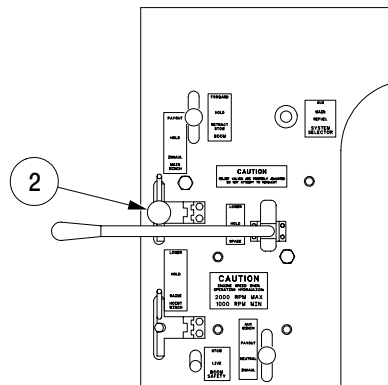

24i084ma

PAY OUT MAIN WINCH CABLE BY BACKTRACKING FROM DISABLED VEHICLE: - CONTINUED

WARNING

Cable can become frayed or contain broken wires. Wear leather-palmed work gloves when handling cable. Frayed or broken wires can injure hands.

Never let cable slide through hands, even when wearing gloves. A broken wire could cut through glove and injure hand.

NOTE

If rigging for a single line pull, do steps 4 and 5. If rigging for a double line pull, do steps 6 through 8.

CAUTION

Main winch cable must be kept under tension when paying out. Failure to comply will cause damage to the main winch.

Start pay out of main winch cable slowly. Fast initial pay out can cause the cable to unspool. Failure to comply may result in damage to main winch.

4. Raise main winch lever cover and move MAIN WINCH operating lever (2) to PAYOUT and pay out enough main winch cable to reach the tow cables.
5. Attach main winch cable to tow cable sling legs using two 18-ton shackles and one 50-ton shackle. This provides a winch point along the disabled vehicle's center line which allows for a straight line pull back to the M88A2. Go to step (9).

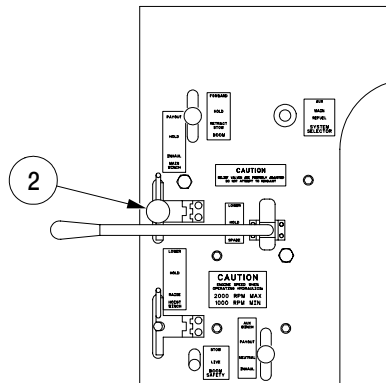

24i084ma

VEHICLE RECOVERY OPERATIONS - CONTINUED**0051 00****PAY OUT MAIN WINCH CABLE BY BACKTRACKING FROM DISABLED VEHICLE - CONTINUED****WARNING**

140-ton (127,120 kg) snatch block weighs 220 lbs (99.8 kg). Use auxiliary boom to stow and unstow. Use three people when lifting or moving. Do not lift above waist. Failure to comply may result in injury to personnel.

CAUTION

Use of M88A2 tow cables as a sling leg on other than M88A2 will affect included angle of sling leg force calculation.

6. Connect 140-ton snatch block to tow cable sling legs using two 50-ton shackles and two 18-ton shackles. Attach one 50-ton shackle to 140-ton snatch block ensuring shackle pin (50-ton) is toward disabled vehicle. Attach second (50-ton) shackle to first 50-ton shackle (pin against pin). Using two 18-ton shackles attach each tow cable to second 50-ton shackle.
7. Move MAIN WINCH operating lever (2) to PAYOUT and pay out enough main winch cable to go through the 140-ton (127,120 kg) snatch block and return to the M88A2 winch lug.
8. Lower spade enough to connect main winch cable over top of spade to M88A2's winch lug with 50-ton shackle.

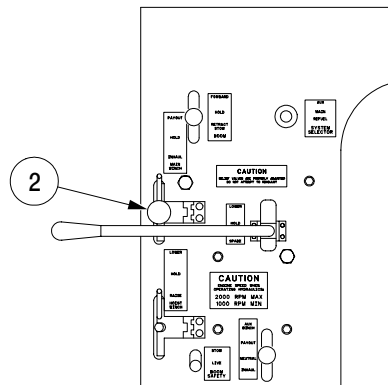

24i084ma

VEHICLE RECOVERY OPERATIONS - CONTINUED**0051 00****PAY OUT MAIN WINCH CABLE BY BACKTRACKING FROM DISABLED VEHICLE - CONTINUED****WARNING**

Use two ground guides to aid driver in backing vehicle. Inadequate guidance during backing operation may result in accidental impact causing injury or DEATH to personnel or damage to equipment.

9. Set engine speed to idle (825 to 875 rpm).
10. With brakes applied, shift transmission selector (3) to R.
11. Release brakes and slowly take up slack in main winch cable.

CAUTION

Start pay out of main winch cable slowly. Fast initial pay out can cause the cable to unspool. Failure to comply may result in damage to the main winch.

12. After slack is removed, move MAIN WINCH operating lever (2) to PAYOUT and begin to pay out main winch cable.

CAUTION

Do not increase engine speed unless necessary to continue reverse direction movement. If engine rpm must be increased, do not over speed main winch. Failure to comply may result in damage to equipment.

13. Continue reverse movement until slightly past previously prepared spade emplacement location.
14. Move MAIN WINCH operating lever (2) to HOLD position, apply brakes and shift transmission selector (3) to neutral (N).
15. Lower spade until spade touches the ground (WP 0046 00).

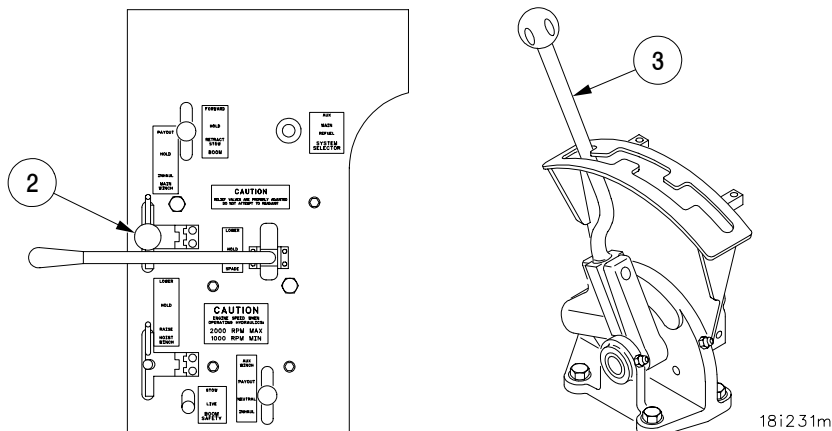

VEHICLE RECOVERY OPERATIONS - CONTINUED**0051 00****PAY OUT MAIN WINCH CABLE BY BACKTRACKING FROM DISABLED VEHICLE - CONTINUED****NOTE**

This procedure will maintain constant tension on the main winch cable.

16. With spade on ground, move MAIN WINCH operating lever (2) to INHAUL and release brakes while continuing to hold SPADE lever (4) in LOWER position.
17. Use main winch to pull M88A2 onto spade and move MAIN WINCH operating lever (2) to HOLD position.
18. Increase engine speed rpm and move MAIN WINCH operating lever (2) to INHAUL to recover disabled vehicle. Keep MAIN WINCH operating lever (2) to INHAUL until disabled vehicle is as close as possible to main winch. This will keep tension on main winch cable during inhaul.
19. Release operating lever.

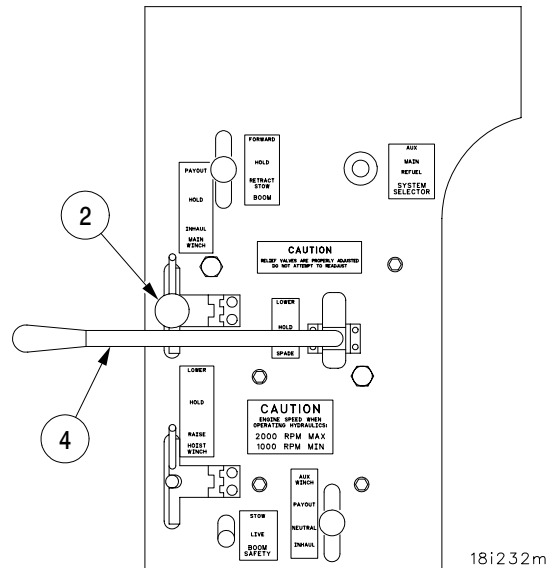
**END OF TASK**

DECALS AND INSTRUCTION PLATES

0052 00

THIS WORK PACKAGE COVERS:

Hydraulic Control Panel, Fuel Control Valves, Driver's Area, Air Filter Housing, Refuel/Defuel Compartment, AN/VIC Intercommunication System (VIS), Engines and Crew Compartments Hose Connection Panel

HYDRAULIC CONTROL VALVE PANEL

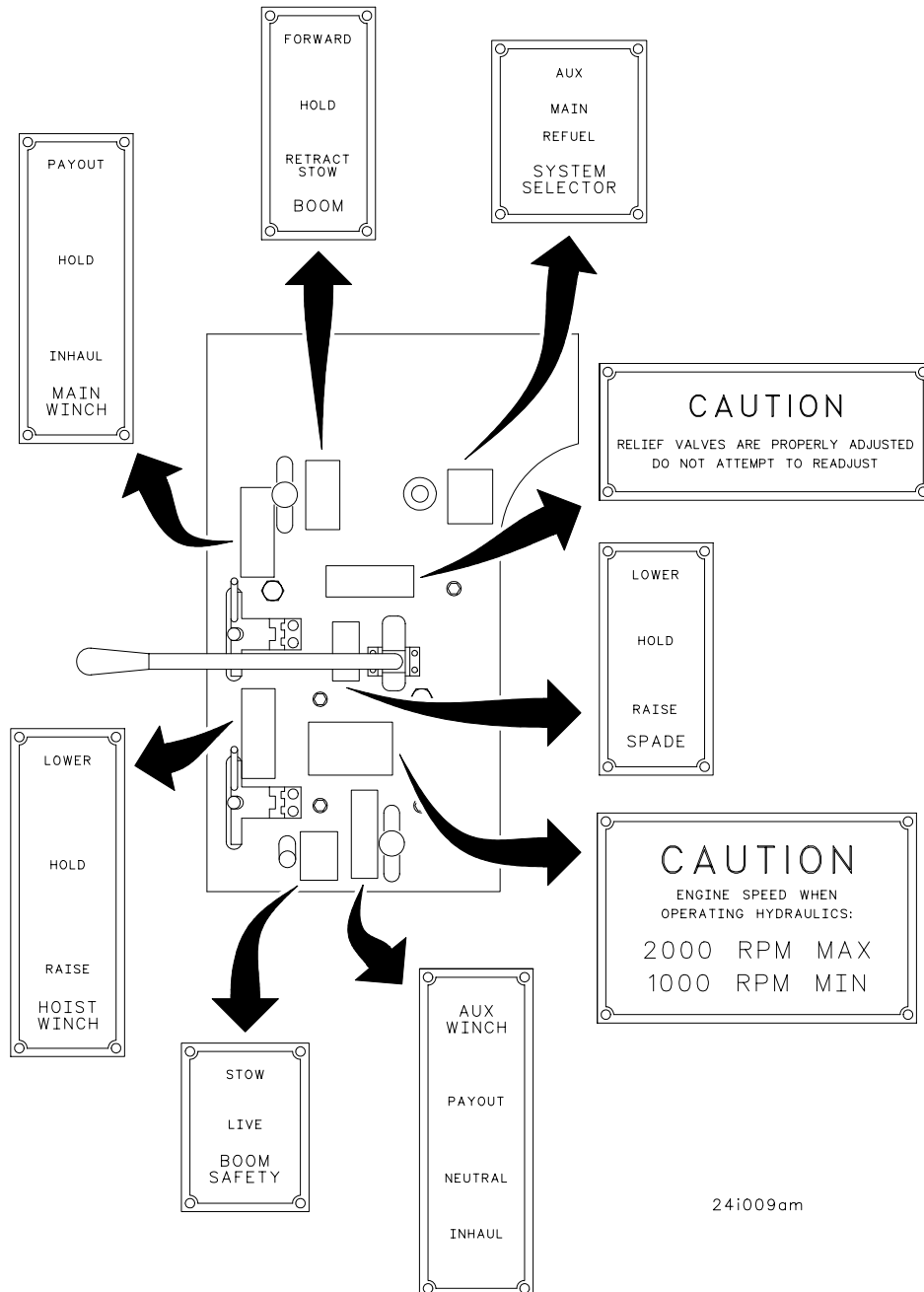

FUEL CONTROL VALVES

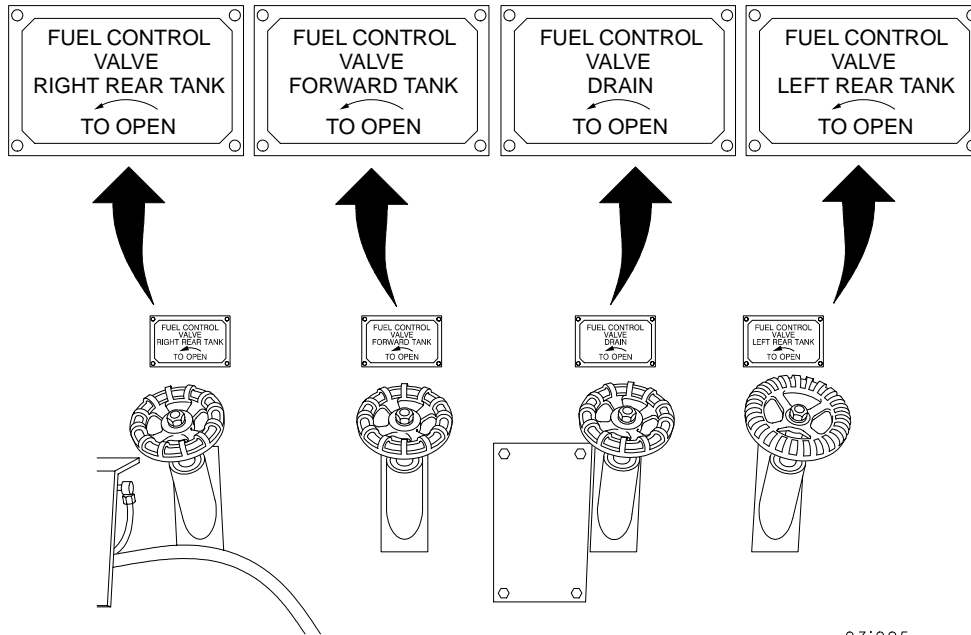

031005ma

DRIVER'S AREA

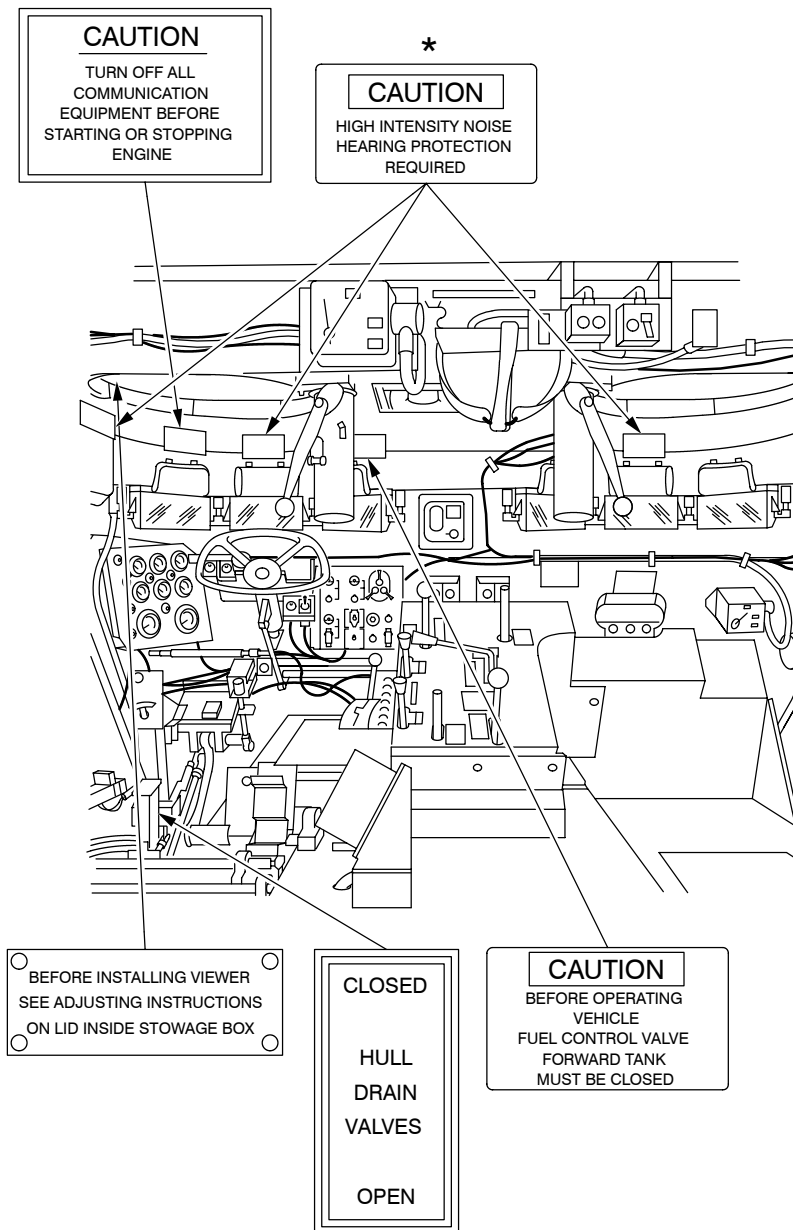

* FOUR ARE REQUIRED IF VEHICLE IS EQUIPPED WITH DVE

18i083ma

AIR FILTER HOUSING



03i006ma

DECALS AND INSTRUCTION PLATES - CONTINUED

0052 00

REFUEL/DEFUEL COMPARTMENT

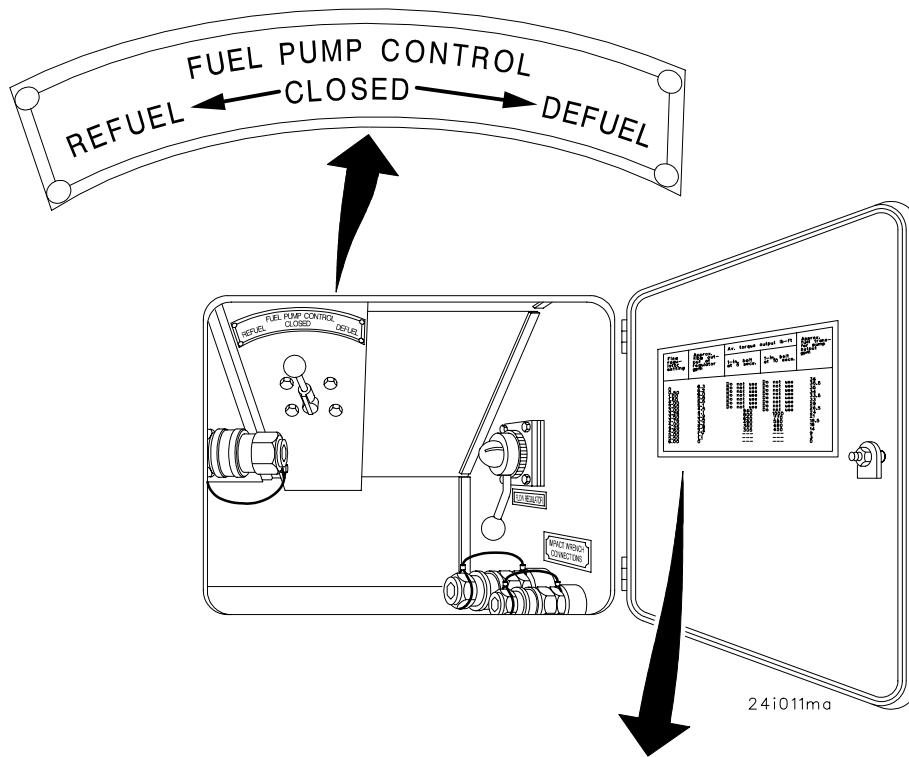

Flow regulator setting	Approx. flow output at regulator gpm	Average torque output lb-ft		Approximate fuel transfer rate gpm
		1-in. bolt at 5 secs.	1-in. bolt at 10 secs.	
0	6.3	Do not use	Do not use	36
0.50	6.2	Do not use	Do not use	35.5
1.00	6.0	Do not use	Do not use	35
1.50	5.8	Do not use	Do not use	34
2.00	5.5	Do not use	Do not use	33.5
2.50	5.1	Do not use	Do not use	33
3.00	4.5	Do not use	Do not use	29
3.25	4.1	940	Do not use	26.5
3.50	3.9	800	1000	24
3.75	3.5	620	770	21
4.00	3.2	490	580	18.5
4.25	2.8	360	480	16
4.50	2.4	305	450	14
5.00	1.7	---	---	9
5.50	1.1	---	---	3
6.00 through 10.00	0	---	---	0

AN/VIC-3(V) VEHICLE INTERCOMMUNICATION SYSTEM (VIS)

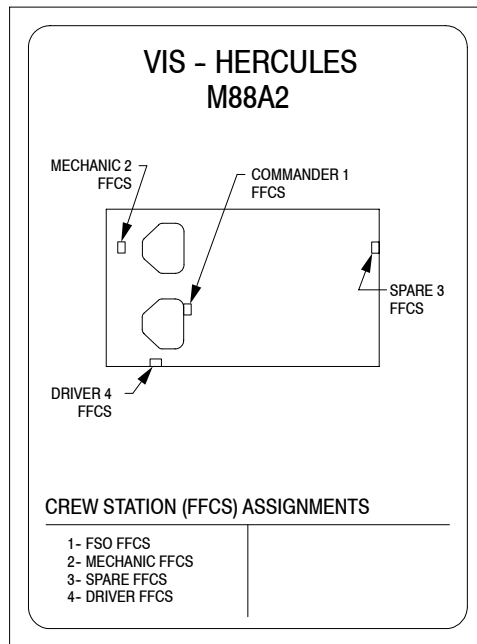
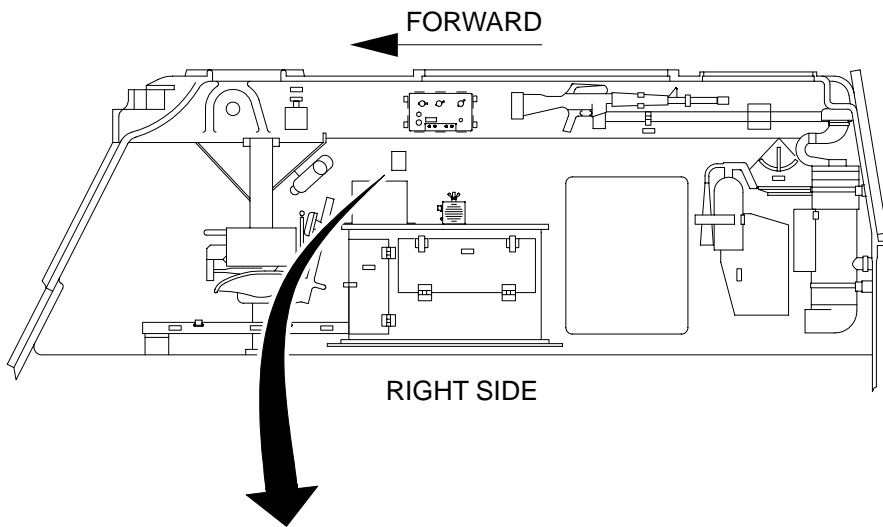

06i162m

HOSE CONNECTION PANEL

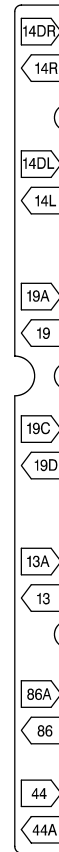
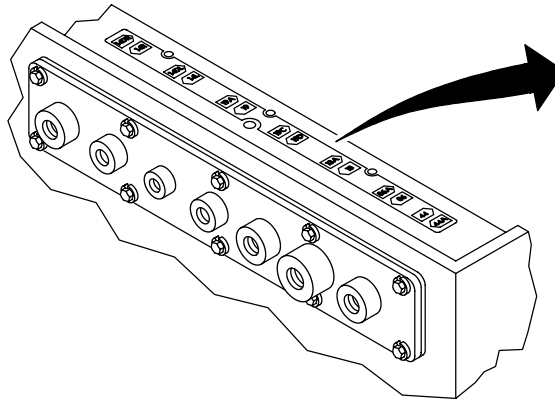
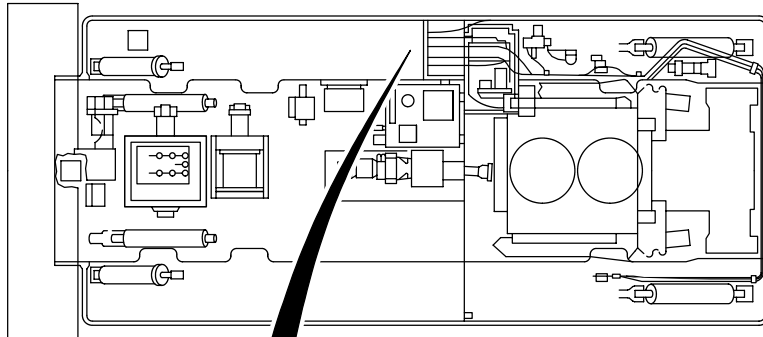

24i119m

DECALS AND INSTRUCTION PLATES - CONTINUED

0052 00

ENGINE OIL CHECK AND FILL DOOR ENGINE COMPARTMENT

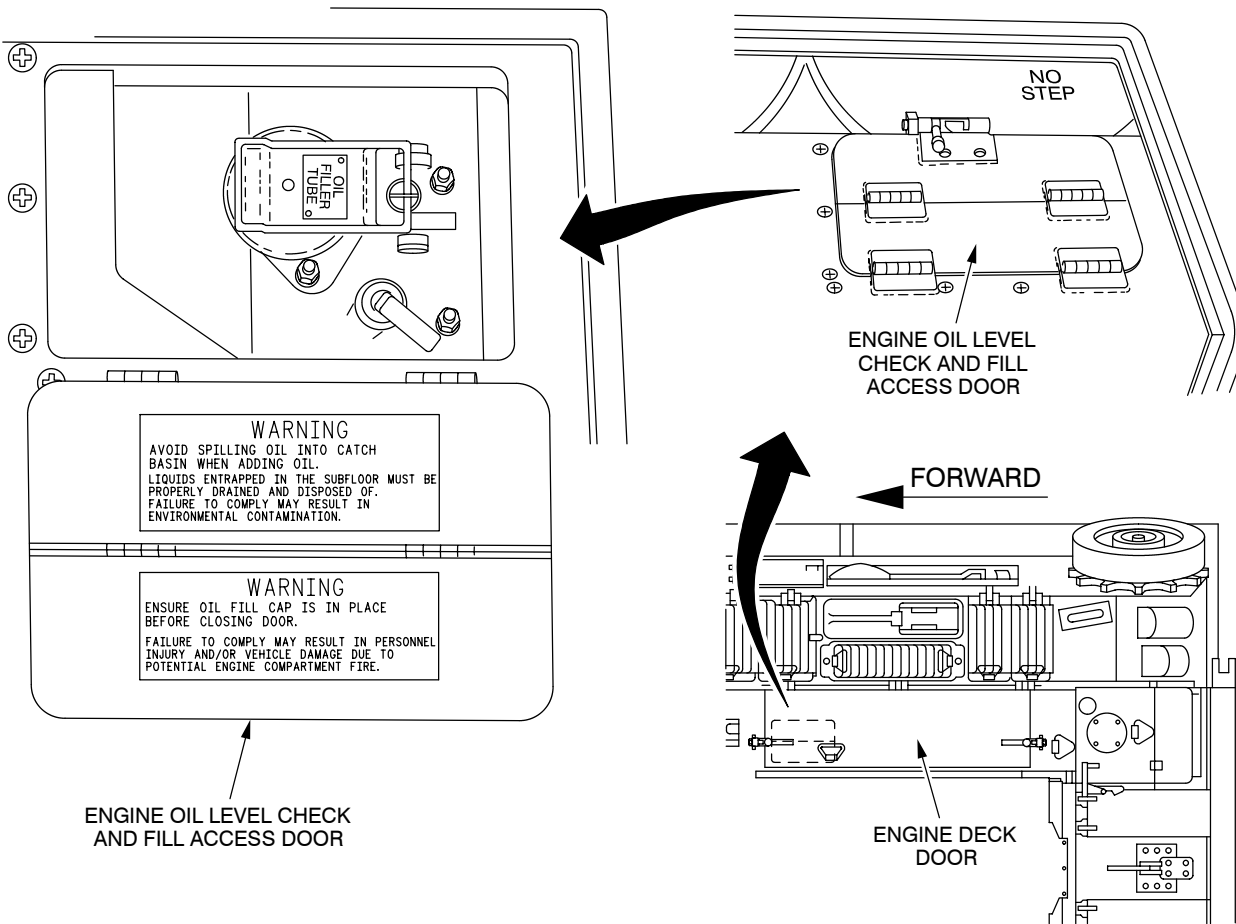

18i265m

END OF TASK

OPERATE AUXILIARY POWER UNIT

0053 00

THIS WORK PACKAGE COVERS:

Starting APU, Stopping APU, Charging Vehicle Batteries

INITIAL SETUP:

Personnel Required

Three

References

- WP 0105 00
- WP 0086 00
- WP 0020 00
- WP 0079 00
- WP 0034 00

The auxiliary power unit (APU) is used to charge vehicle batteries, power impact wrench or refuel/defuel pump, and, in an emergency, it can raise/lower boom or spade, retrieve main/hoist/auxiliary winch cables, or lower hoisted load to ground.

STARTING APU

NOTE

To start APU in extremely cold weather (0° to -25° F (-17° to -31°C)) refer to (WP 0079 00).

If rear fuel tanks are too low for APU operation, open forward tank valve (WP 0020 00). Close valve when you are finished.

When operating APU on side slopes, ensure vehicle has at least a quarter tank of fuel and close fuel control valve to the right rear fuel tank (WP 0020 00). Open valve when you are finished.

To operate hydraulics system, SYSTEM SELECTOR lever must be in MAIN position. To operate REFUEL/DEFUEL system or impact wrench, SYSTEM SELECTOR must be in REFUEL position.

1. Check APU chaincase and crankcase oil levels (Table 6, WP 0105 00).
2. Turn OFF all radio and electrical switches.
3. Set SYSTEM SELECTOR control lever (1) to MAIN.

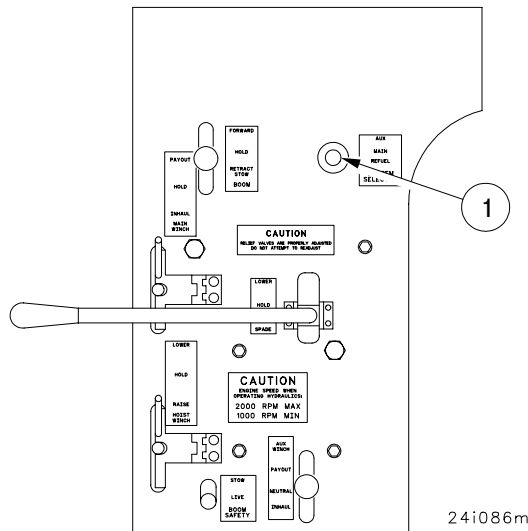

OPERATE AUXILIARY POWER UNIT - CONTINUED

0053 00

STARTING APU - CONTINUED

4. Set PTO CLUTCH switch (2) to OFF.
5. Set MASTER switch (3) ON.
6. Set FUEL PUMP switch (4) OFF.

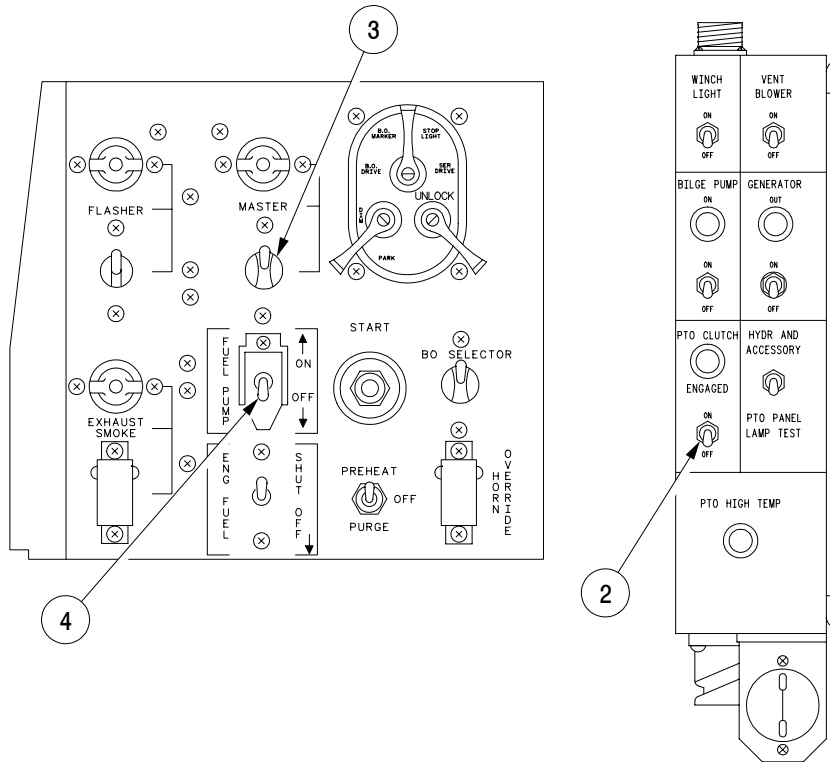

06i005mf

OPERATE AUXILIARY POWER UNIT - CONTINUED**0053 00****STARTING APU - CONTINUED**

7. Set APU GEN switch (5) to OFF.
8. Set FUEL SHUTOFF switch (6) ON.

NOTE

The LOW OIL PRESSURE indicator will light and stay on until the APU is running.

The PREHEAT switch is held up until the APU starts.

9. Hold the PREHEAT switch (7) up for 20 seconds (for temperatures above 55° F (13° C)) or for 1 minute (for temperatures below 55° F (13° C)).
10. Move START switch (8) to ON and hold until engine starts. If engine doesn't start in 1 minute, release the START switch and keep the PREHEAT switch up for another 20 seconds (or 1 minute below 55° F(13° C)). Try starting APU again. If it still doesn't start, troubleshoot (WP 0086 00).

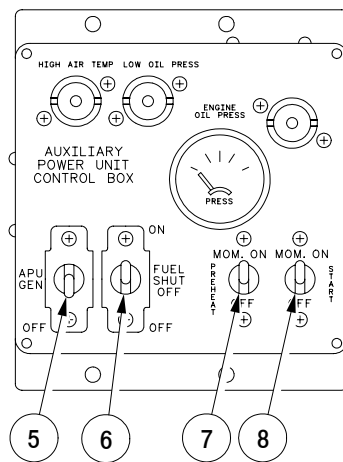

061166m

CAUTION

If LOW OIL PRESSURE indicator stays on after the APU starts, or comes on while APU is running, turn FUEL SHUTOFF switch to OFF to stop APU. Failure to comply may result in failure of the APU.

11. When the APU starts, release both the PREHEAT and START switches.
12. Let APU warm up for three to five minutes before turning on the APU GEN switch (5) or operating the auxiliary hydraulic system.

STARTING APU - CONTINUED

CAUTION

If HIGH AIR TEMPERATURE indicator lights during APU operation, turn off the APU and let it cool. If indicator comes on often, notify unit maintenance. Failure to comply may result in failure of the APU.

13. While APU is running, check gauge and indicators on APU control box (9) frequently for possible malfunctions.

STOPPING APU

1. To stop the APU, turn APU GEN switch (5) and FUEL SHUTOFF switch (6) to OFF.
2. If the APU continues to run, turn OFF MASTER switch (3).

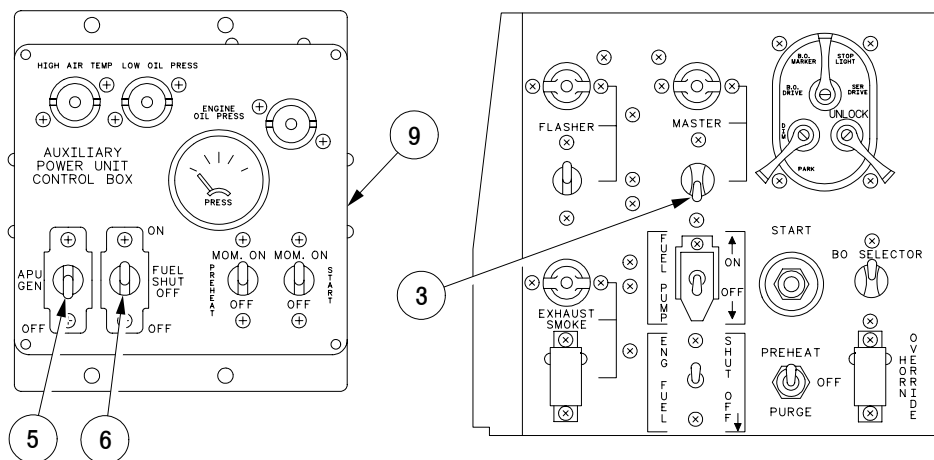

06i167m

OPERATE AUXILIARY POWER UNIT - CONTINUED

0053 00

STOPPING APU - CONTINUED

3. If the APU still continues to run, go outside, open right side engine grille doors (10) (WP 0034 00), and turn emergency fuel shutoff valve (11) to OFF.

CHARGING VEHICLE BATTERIES

1. Start the APU in accordance with this work package.
2. Set APU GEN switch (5) to ON.
3. Check BATT-GEN gauge (12) on gauge panel (13) to confirm needle is in green area.
4. Allow APU to charge batteries for 30 minutes.
5. Turn APU GEN switch (5) to OFF.
6. Stop APU in accordance with this work package.

NOTE

If there is not enough power to start main engine after charging batteries, notify unit maintenance.

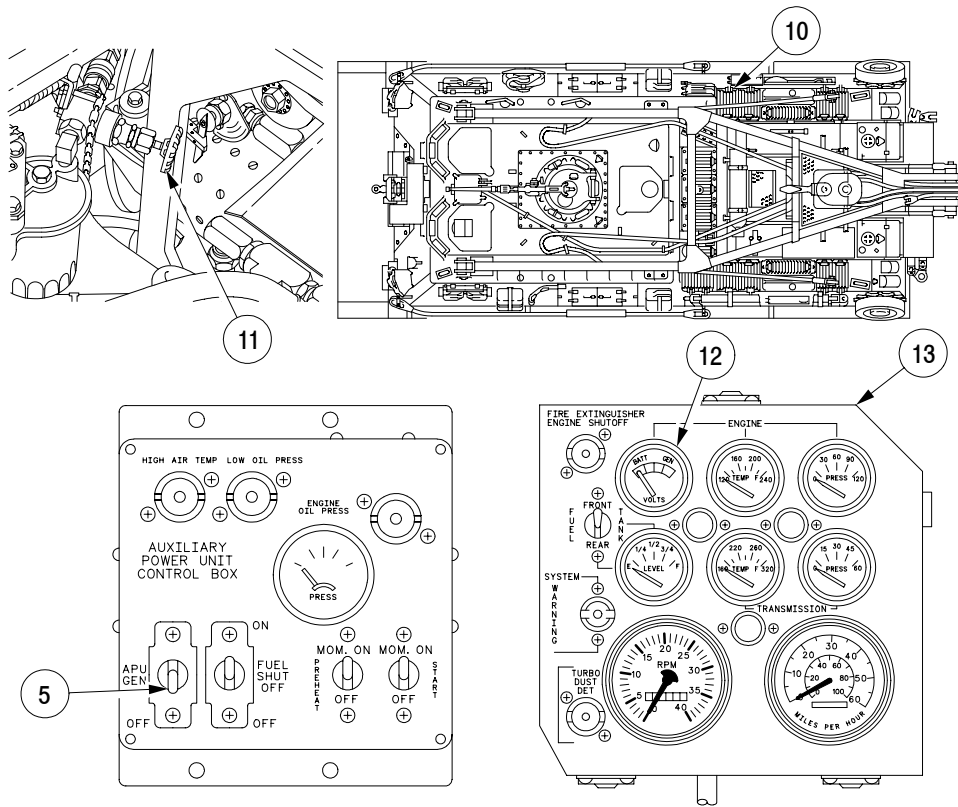

03i316m

END OF TASK

REFUEL AND DEFUEL OPERATION**0054 00****THIS WORK PACKAGE COVERS:**

Refuel and Defuel Operation

INITIAL SETUP:**Tools and special Tools**

Nozzle and fuel hose assembly (item 30, Table 1, WP 0133 00)
 Long tube (item 46, Table 1, WP 0133 00)

Materials/Parts

Wiping rags (item 45, WP 0135 00)

Personnel Required

Three

References

WP 0053 00
 WP 0020 00
 WP 0133 00
 WP 0135 00

The refuel/defuel pump is used when fueling the vehicle from drums or from another vehicle. It is also used to transfer fuel from the M88A2 to another vehicle. The refuel/defuel pump is hydraulically driven and is powered by the auxiliary hydraulic system. The controls and fuel hoses for refuel/defuel pump are in right side stowage compartment on outside of the vehicle.

WARNING

JP8 is flammable. Do not perform this procedure near fire, flame or sparks. Personnel are not allowed to smoke within 50 feet (15m). Failure to comply may result in injury or DEATH to personnel.

Fuel and oil are slippery and can cause falls. Clean up spilled fuel with rags. Dispose of fuel-soaked rags in accordance with unit policy. Failure to comply may result in injury to personnel.

1. Set the FUEL CONTROL VALVES for the REFUEL/DEFUEL position (WP 0020 00).
2. Set the FUEL PUMP CONTROL handle (1) to CLOSED.
3. Move the FLOW REGULATOR handle (2) to the 10 position.
4. Select filler tube for desired operation, long tube (3) for refuel and short tube (4) for defuel.
5. Place filter (5) in filler tube (3 or 4), remove dust cap (6) and screw the tube onto the nozzle (7) hand tight (if leakage occurs the tube may be slightly tightened by wrench).
6. Remove fuel hose connection cap (8) and fuel hose plug (9) and connect the fuel hose (10) to fuel hose connector (11).

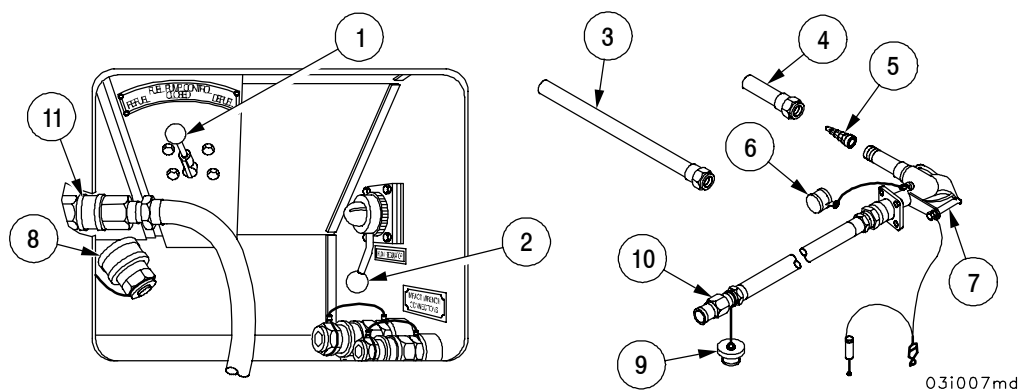

REFUEL AND DEFUEL OPERATION - CONTINUED

0054 00

7. Start APU (WP 0053 00) and shift the SYSTEM SELECTOR control lever (12) to REFUEL.

CAUTION

Do not change FUEL PUMP CONTROL handle setting without setting FLOW REGULATOR handle to the 10 position. Failure to comply may result in failure of the hydraulic system.

8. Move FUEL PUMP CONTROL handle (1) to desired position (REFUEL places fuel into the M88A2, DEFUEL removes fuel from the M88A2).

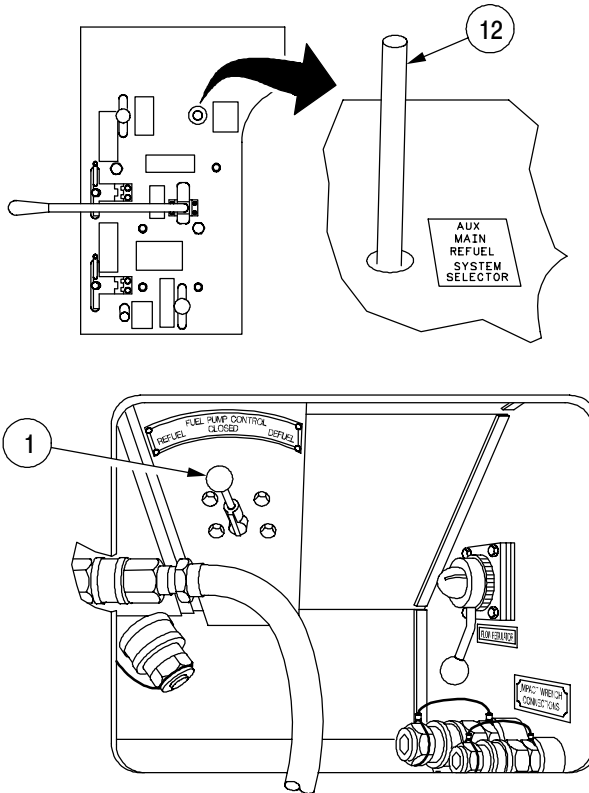

03i007mc

REFUEL AND DEFUEL OPERATION - CONTINUED

0054 00

9. Set FLOW REGULATOR handle (2) to desired position. Refer to chart below for flow setting. Normal operating range will be 3.25 on flow regulator setting. This is about 26 gallon per minute (gpm).

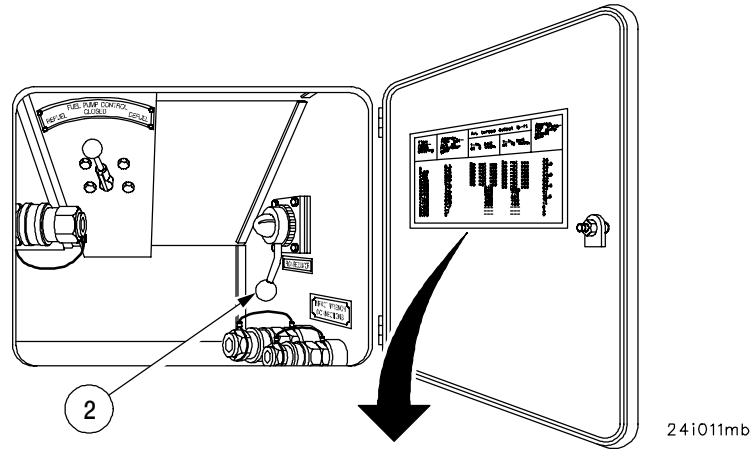

Flow regulator setting	Approx. flow output at regulator gpm	Average torque output lb-ft		Approximate fuel transfer rate gpm
		1-in. bolt at 5 secs.	1-in. bolt at 10 secs.	
0	6.3	Do not use	Do not use	36
0.50	6.2	Do not use	Do not use	35.5
1.00	6.0	Do not use	Do not use	35
1.50	5.8	Do not use	Do not use	34
2.00	5.5	Do not use	Do not use	33.5
2.50	5.1	Do not use	Do not use	33
3.00	4.5	Do not use	Do not use	29
3.25	4.1	940	Do not use	26.5
3.50	3.9	800	1000	24
3.75	3.5	620	770	21
4.00	3.2	490	580	18.5
4.25	2.8	360	480	16
4.50	2.4	305	450	14
5.00	1.7	---	---	9
5.50	1.1	---	---	3
6.00	0	---	---	0
through 10.00				

WARNING

All personnel must dismount from vehicles and the portable fire extinguishers must be readily accessible and manned at all times. Failure to comply may result in injury or DEATH to personnel.

CAUTION

When refueling the M88A2, remove fuel filler cap for venting and have an observer watch fuel tank filler pipe to avoid overfilling and spillage of fuel. Fill to the level of screen at bottom of fuel filler pipe. Do not over fill. Failure to comply may result in damage to equipment.

10. Ground fuel hose assembly by connecting the attached ground cable (13) to one of the vehicles.
11. Open fuel tank filler cap and insert tube firmly into fuel tank filler pipe. Avoid damaging filler pipes or strainers.
12. Avoid overfilling by attending fuel nozzle continuously. Lock or latch-open devices that permit unattended operation are NOT AUTHORIZED (any nozzles which have the notched handles must have the notches removed).
13. After refuel/defuel operation is complete, move FLOW REGULATOR handle (2) to the 10 position.
14. Set FUEL PUMP CONTROL handle (1) to CLOSED.

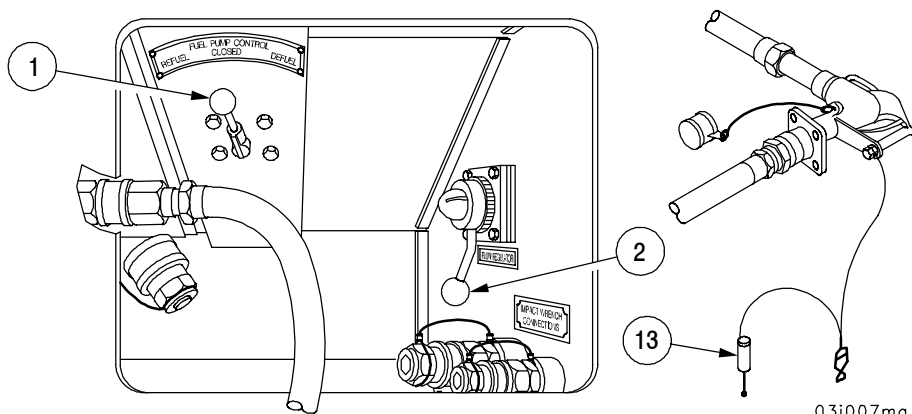

REFUEL AND DEFUEL OPERATION - CONTINUED

0054 00

15. Engage nozzle handle (7) to relieve fuel pressure in hose (10). Remove tube from fuel tank filler pipe and replace fuel tank filler cap.
16. Remove ground cable (13).
17. Shift SYSTEM SELECTOR control lever (12) to MAIN.
18. Shut down APU (WP 0053 00) if there is no further need for it at this time.
19. Disconnect fuel hose (10) and replace hose connection cap (8) and plug (9).
20. Ensure short filler tube (4) with filter (5) is installed on nozzle (7), with dust cap (6) in place, before the unit is stowed.
21. Clean up any spilled fuel using wiping rags.

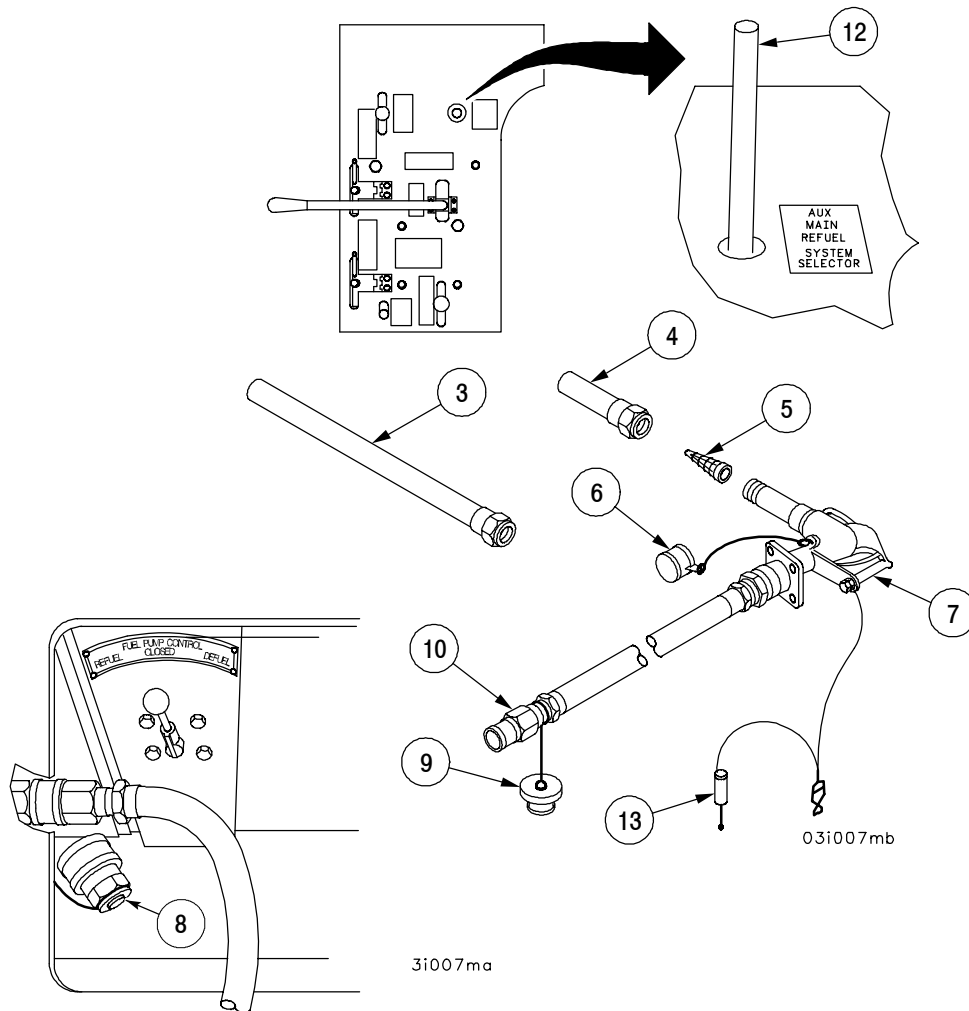

END OF TASK

OPERATE IMPACT WRENCH**0055 00****THIS WORK PACKAGE COVERS:**

Operate Impact Wrench

INITIAL SETUP:**Tools and special Tools**

Hydraulic impact wrench (item 49, Table 1, WP 0133 00)
 Hydraulic impact hose (AR) (item 23, Table 1, WP 0133 00)
 Hydraulic impact hose (AR) (item 24, Table 1, WP 0133 00)

References

TM 9-5130-338-12&P
 WP 0133 00
 WP 0053 00
 WP 0054 00

A portable hydraulic impact wrench with hoses is located in the left stowage compartment. It is a 3/4-inch square drive wrench with two 3/8-inch and two 1/2-inch quick disconnect, self-sealing hoses located in the right stowage compartment. The impact wrench is hydraulically-driven by the auxiliary hydraulic system. Refer to TM 9-5130-338-12&P for maintenance of the wrench.

1. Check that FUEL PUMP CONTROL handle (1) is in CLOSED position.
2. Remove hose connection caps from impact wrench, impact wrench hoses and hydraulic compartment connectors.
3. Connect two impact wrench hoses (2) to quick-disconnect couplings (3) on impact wrench (4) and hydraulic hose connections (5).
4. Move FLOW REGULATOR control handle (6) to the 10 position.
5. Start APU (WP 0053 00).

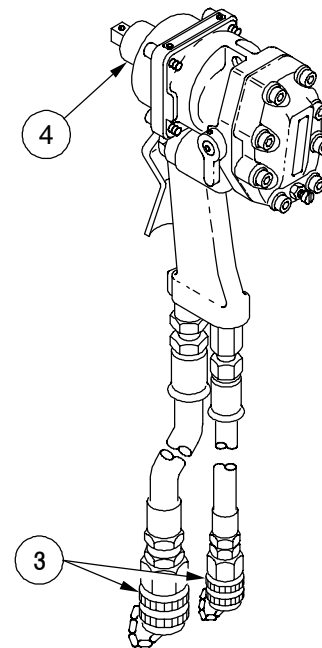
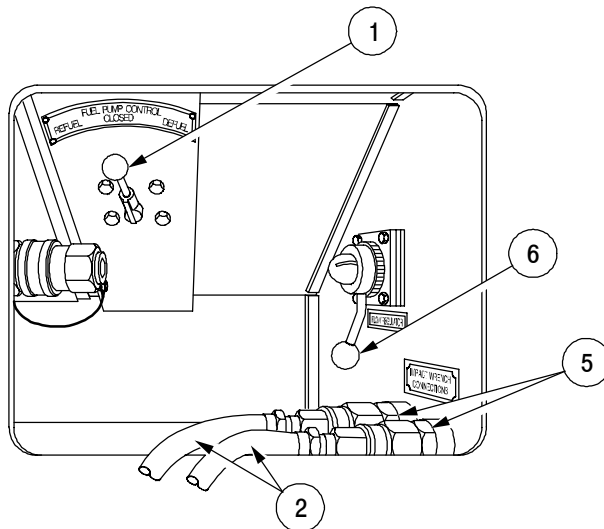

26i006m

OPERATE IMPACT WRENCH - CONTINUED**0055 00**

6. Shift SYSTEM SELECTOR control lever (7) to REFUEL.
7. Check torque requirements for item being worked on, then adjust FLOW REGULATOR control handle (6) for approximate torque setting. Use chart (WP 0054 00) as a reference.
8. Set rotary switch (8) for direction of wrench rotation. Be sure switch is turned all the way left or right. Push and hold trigger (9) to operate wrench.
9. When finished with impact wrench, move FLOW REGULATOR control handle (6) to 10 position.
10. Move SYSTEM SELECTOR control lever (7) to MAIN.
11. Shut down APU (WP 0053 00).
12. Disconnect hoses (2) from impact wrench (4), quick-disconnect couplings (3) and vehicle quick-disconnect couplings (5).
13. Install hose connection caps on impact wrench, impact wrench hoses and hydraulic compartment connectors.
14. Stow impact wrench and hoses.

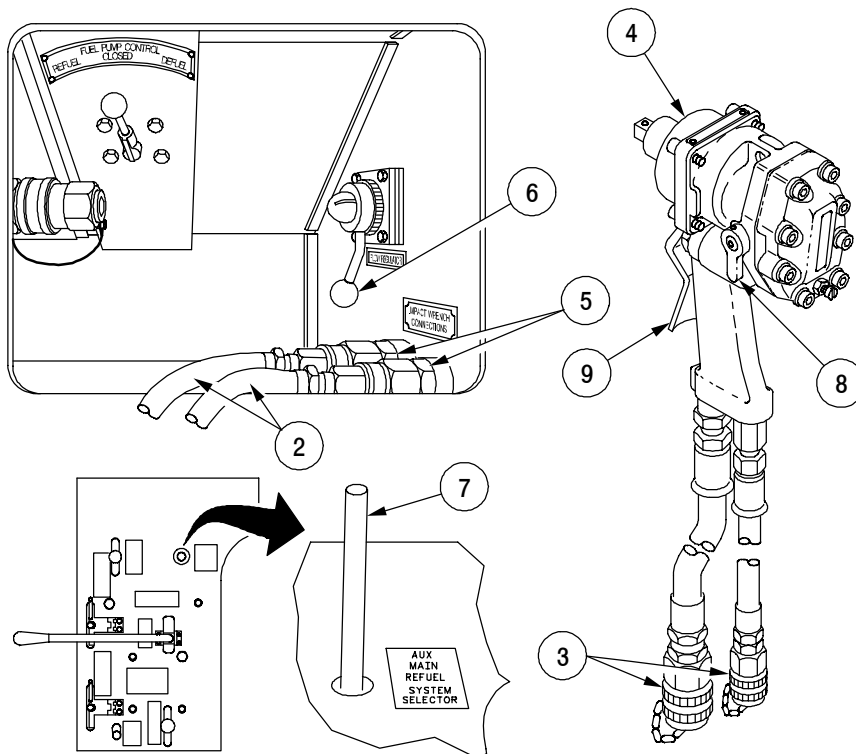

26i022ma

END OF TASK

OPERATE PERSONNEL HEATER**0056 00****THIS WORK PACKAGE COVERS:**

Operate Personnel heater

INITIAL SETUP:**References**

WP 0097 00

The personnel heater provides heat for the crew compartment in cold weather. The heater burns fuel from the fuel tanks.

WARNING

Shut off the personnel heater if: fuel leakage or fuel pooling is observed; heater will not start in specified time following proper procedures (heater lamp does not come on); blower does not operate or heater goes out (heater lamp goes out). Failure to comply may result in personnel injury or DEATH and/or equipment damage due to potential for a crew compartment fire.

1. Press indicator light (1) to see if it glows. If it doesn't glow, replace it. If it still doesn't glow, troubleshoot (WP 0097 00).
2. Set HI/LO switch (2) to desired position for heat control.
3. Hold heater control switch (3) to START.
4. Wait two to four minutes for indicator light (1) to come on.
5. Move heater control switch (3) to RUN.
6. If light (1) fails to glow, move heater control switch to OFF. Press indicator light (1). If it lights, wait two minutes and try to start heater again. If it doesn't light, troubleshoot (WP 0097 00).
7. To stop heater, move heater control switch (3) to OFF. Light (1) will go out in a short time.

NOTE

The heater can be operated with MASTER switch OFF. Operate in this mode for only short periods of time. The batteries will drain quickly in cold weather.

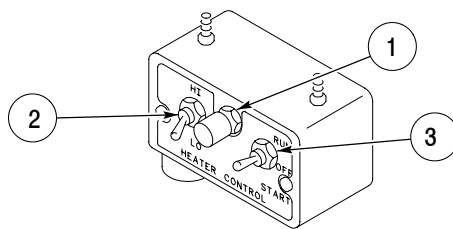

18i216m

END OF TASK

OPERATE PERSONNEL HEATER GLOBAL (A20)

0057 00**THIS WORK PACKAGE COVERS:**Operate Personnel heater

INITIAL SETUP:**References**

WP 0098 00

WP 0097 00

The personnel heater provides heat for the crew compartment in cold weather. The heater burns fuel from the fuel tanks.

WARNING

Shut off the personnel heater if: fuel leakage or fuel pooling is observed; heater will not start in specified time following proper procedures (heater lamp does not come on); blower does not operate or heater goes out (heater lamp goes out). Failure to comply may result in personnel injury or DEATH and/or equipment damage due to potential for a crew compartment fire.

Should heater not start within three (3) consecutive attempts, refer to WP 0098 00 and troubleshoot heater system. DO NOT attempt to start a flooded heater or use starting aids such as ether to assist in heater start up, or a fire hazard may occur resulting in possible injury or death to personnel.

DO NOT place combustible materials within three (3) feet of heater exhaust. Failure to comply may result in personnel injury or DEATH and/or equipment damage due to fire.

DO NOT smoke or allow open flames nearby while conducting maintenance work on heater as diesel fuel and its fumes can be explosive.

If heater has been running recently, the ignitor, exhaust port and heat exchanger are hot enough to burn unprotected skin.

Hearing can be PERMANENTLY DAMAGED if exposed to constant noise levels of 85dBA or greater. Wear approved hearing protection devices when working within two feet of the heater inlet.

After disconnecting electrical power from heater and detaching MS power connector, the pins A and D of heater's male connector remain electrically live with 24 Vdc. This condition remains for approximately five (5) minutes while a capacitor discharges. Personnel should avoid touching contacts.

WARNING

Carbon monoxide is a colorless odorless gas, and if inhaled, can be lethal. Never operate a heater indoors without venting exhaust outdoors. The heater consumes oxygen and produces carbon monoxide gas that is vented through heater exhaust.

CAUTION

If black smoke is noticed during any mode of heater operation, shut down heater, and check for airflow obstructions. It is possible frost has built up in the combustion air intake or that debris has entered into the combustion system. Failure to comply may result in heater damage.

The personnel heater may not start or run above 75°F. Do not attempt to operate heater if vehicle interior temperature is above this temperature. Heater will display a fault code if vehicle interior temperature is above 104°F. The heater will automatically switch to LO if vehicle interior temperature is above 113°F. Heater will not start or shut down if vehicle interior temperature is above 131°F. Heater will shut down if heater output temperature is above 345 °F.

NOTE

The heater can be operated with MASTER switch OFF. Operate in this mode for only short periods of time. The batteries will drain quickly in cold weather.

OPERATE PERSONNEL HEATER GLOBAL (A20) - CONTINUED**0057 00****START THE HEATER**

1. Make sure deep water fording plug is removed from combustion air intake and heater exhaust (WP 0005 00).
2. The START/OFF/RUN switch (1) on control box (2) should initially be in OFF position.
3. Press indicator light (3) to see if it glows. If it doesn't glow, replace it. If it still doesn't glow, troubleshoot (WP 0097 00).

NOTE

The heater can be started with the HI/LO switch in HI or LO position.

Heater life will be extended if operated in LO temperature setting.

4. Set HI/LO switch (4) to desired position for heat control.
5. Move START/OFF/RUN switch (1) to START and hold for approximately four seconds, then move the switch directly to RUN position. Heater will run automatically.
6. Wait 3.5 minutes for indicator light (3) to come on.
7. If indicator light (3) fails to come on within 3.5 minutes, move START/OFF/RUN switch (1) to OFF, and allow heater to purge (this will take approximately four minutes). Attempt to start heater. If heater does not start, go to troubleshooting procedures (WP 0098 00). Attempt to start heater, if heater does not start after total of three tries, notify UNIT maintenance.

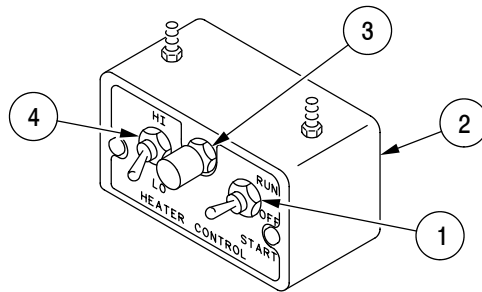

18i216ma

HEATER SHUTDOWN**NOTE**

During shut down and purge cycle, the heater will not respond to control box switch until the 4 minute purge cycle is completed.

When the personnel heater is OFF, the blower will run and the heater indicator light will remain illuminated until the heater purge cycle is completed. Driver should remain in the vehicle until heater shut down is complete.

Move START/OFF/RUN switch (1) to OFF position on control box (2).

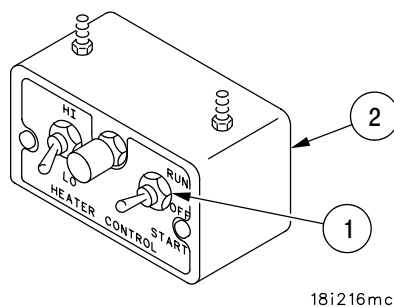

HEATER OPERATION FAULTS

Warning Faults

During operation, if an abnormal condition occurs, indicator light (3) on heater control box (2) will begin flashing and a code (07 or 14) will be displayed on diagnostic display. The heater will try to correct the fault. If fault cannot be corrected, heater will continue to operate until an unsafe condition or component failure FAULT occurs. Then heater will automatically shut down and a failure code will be displayed on the diagnostic display. (Refer to Table 1 Warning Faults.) Go to WP 0098 00 and troubleshoot heater system.

Shutdown Faults

If, during operation, a shutdown fault occurs, the heater will immediately enter the shutdown and purge modes to avoid operating in an unsafe condition. The diagnostic display will display the fault mode and the control box indicator lamp will flash in cycle composing of one flash followed by a 2 second delay. Refer to Table 2 for Shutdown Faults. Then go to WP 0098 00 and troubleshoot heater system.

E2	Low Fuel Pressure
F3	Heat Limit
F6	Ambient Over Temperature

Table 1. WARNING Faults

C3	Vent Fan Fault
E1	Low Voltage
E3	Low Burner Air Flow
F1	Ignition Overtime
F2	Burner Flameout
F4	Vent Air Overheat
F7	Exhaust Overheat

Table 2. SHUT DOWN Faults

If any other codes are displayed notify UNIT maintenance.

EMERGENCY SHUTDOWN

WARNING

In the event of an emergency shutdown, DO NOT TOUCH the heater until it has had sufficient time to cool. The heat exchanger remains at full temperature and the heater will not have completed a purge cycle, both of which pose a safety hazard.

In the event of an unsafe condition, and the heater does not automatically shutdown or respond the manual shutdown procedure, and an emergency shutdown is required, perform the following sequence:

1. Disconnect the power circuit breaker to the heater.
2. Disconnect the heater power by detaching the MS power connection from the heater.

Manual Purge

1. Move START/OFF/RUN switch (1) to OFF position.
2. Move START/OFF/RUN switch (1) on heater control box (2) momentarily to START position for at least 10 seconds, then to OFF. This will allow heater to purge. (This will take approximately four minutes.)

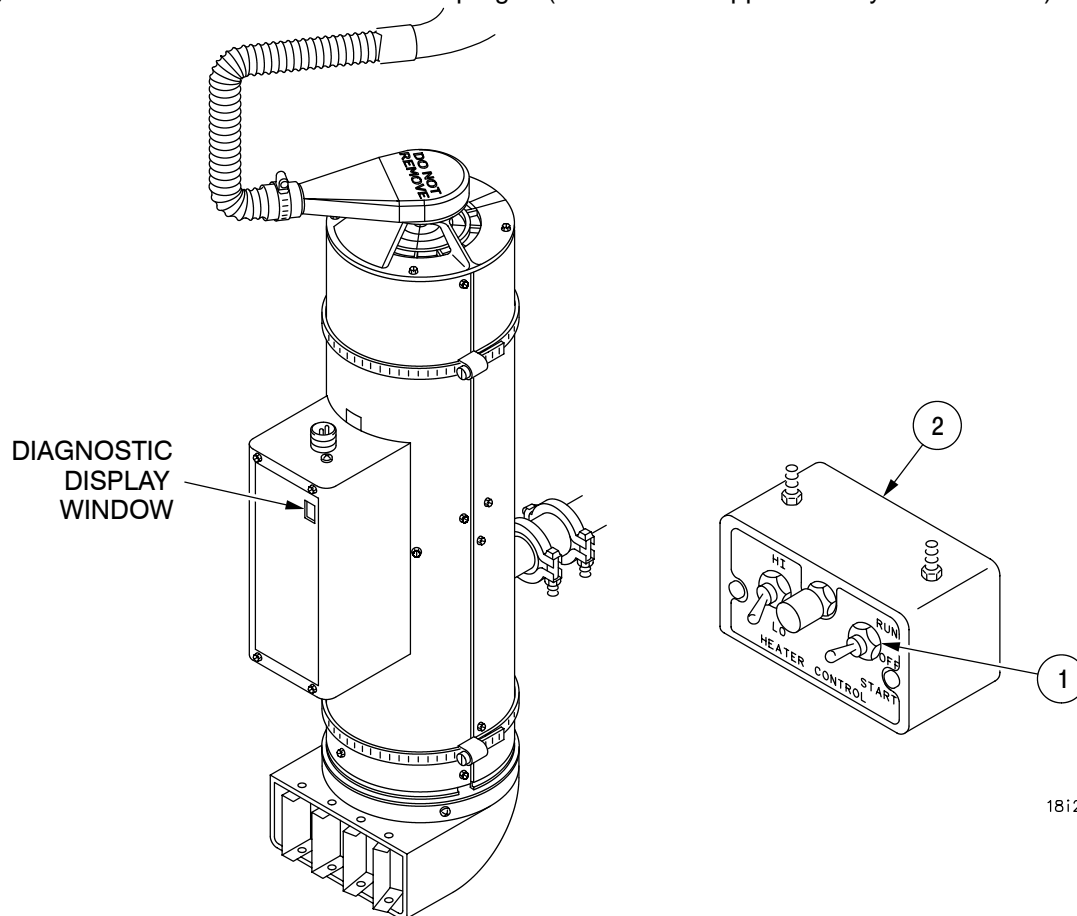

18i216mb

END OF TASK

OPERATE VENTILATING BLOWER

0058 00

THIS WORK PACKAGE COVERS:

Operate Ventilating Blower

The ventilating blower circulates fresh air throughout crew compartment.

WARNING

Do not operate ventilating blower in an area where the air is contaminated. Failure to comply may result in personnel breathing contaminated air, causing injury or DEATH to personnel.

1. Set MASTER switch (1) to ON.
2. Turn FUEL PUMP switch (2) to OFF.
3. Set VENT BLOWER switch (3) on the PTO/Accessory panel to ON.
4. To stop operation, turn VENT BLOWER switch (3) to OFF.
5. Set MASTER switch (1) to OFF.

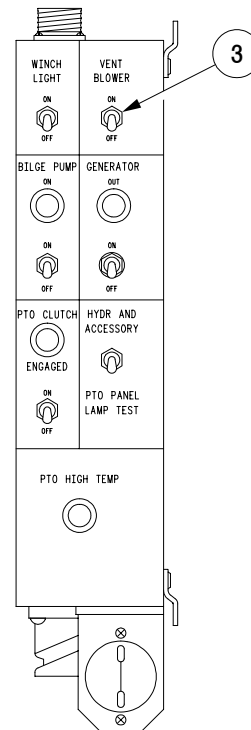
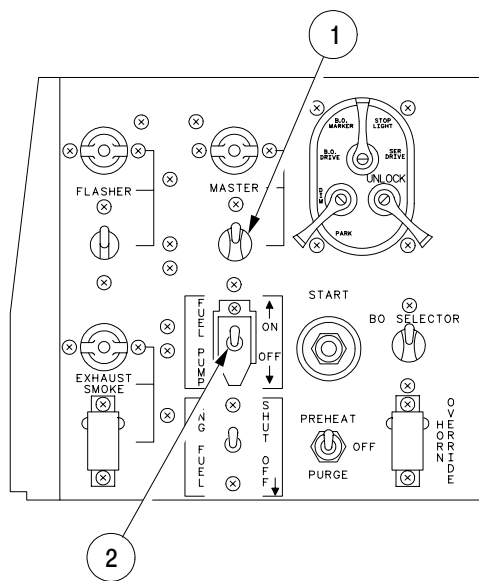

06i005me

END OF TASK

OPERATE PASSIVE NIGHT VIEWER AN-VVS-2(V)1A

0059 00

THIS WORK PACKAGE COVERS:

Installing Passive Night Viewer, Removing Passive Night Viewer

INITIAL SETUP:

Tools and special Tools

Passive night viewer AN-VVS-2(V) 1A (item 47,
Table 1, WP 0133 00)

References

TM 11-5855-249-10
WP 0133 00

The AN/VVS-2(V)1A passive night viewer is a through-the-hatch periscope for armored vehicles. The passive night viewer enables the driver to drive at night under blackout conditions. It also can be used to observe around the vehicle at night. The equipment uses an electronic tube and circuitry to increase brightness of low light levels. Inside the vehicle the user sees a much brighter, green-colored picture of low light view outside the vehicle. For operation and maintenance, refer to TM 11-5855-249-10. During daylight, and when not in use, the passive night viewer is stored in its stowage compartment on the hoist winch cable chute.

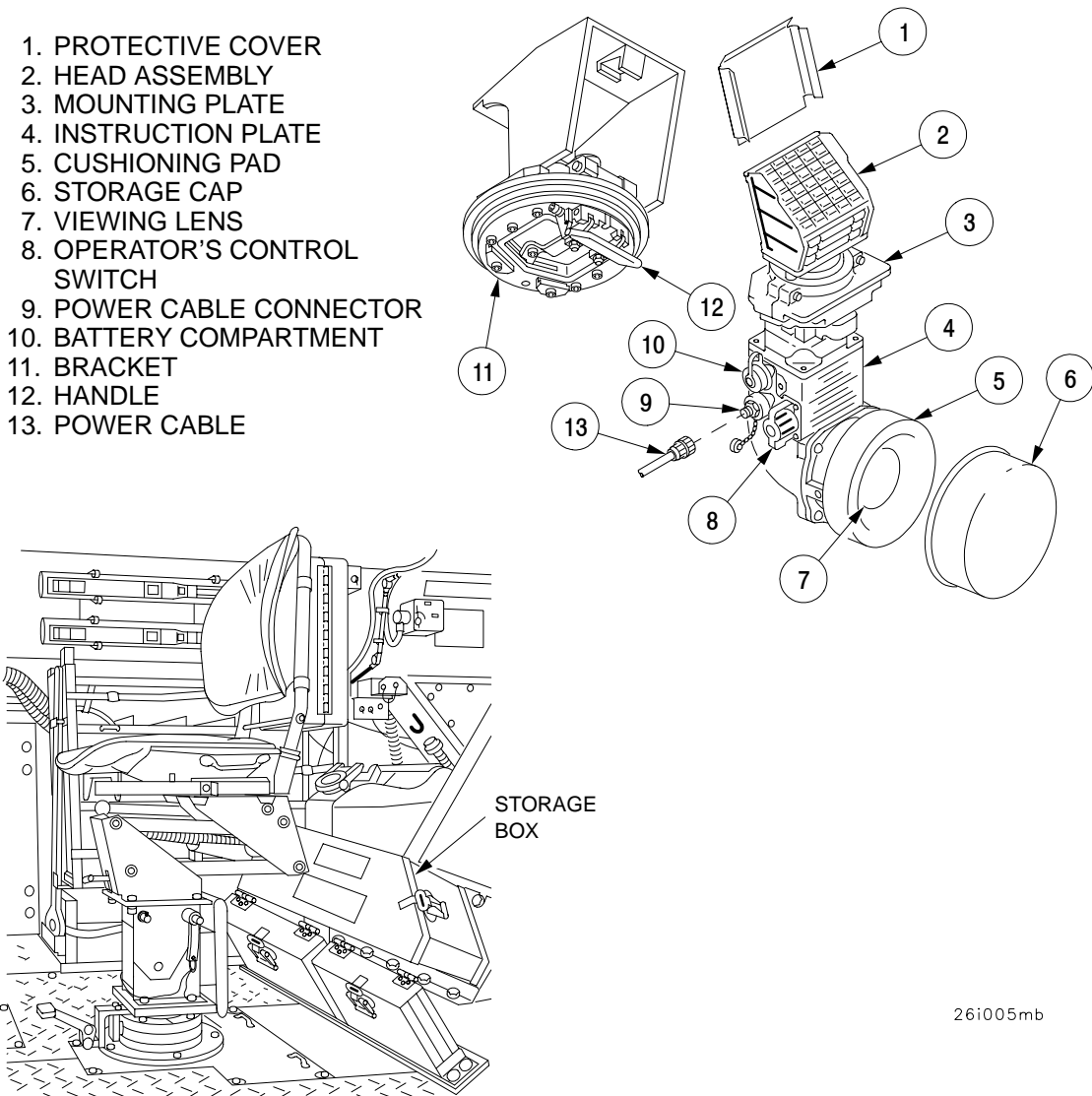

26i005mb

INSTALLING PASSIVE NIGHT VIEWER

1. Remove passive night viewer from storage box.
2. Slide passive night viewer into bracket (11).
3. Pull back on passive night viewer and secure with handle (12).
4. Disconnect power cable (13) from storage bracket and connect to passive night viewer.

**CAUTION**

Check and ensure that battery is removed from battery compartment to prevent damage to equipment.

5. Turn MASTER SWITCH ON.
6. Turn passive night viewer switch (8) to BRIGHT.
7. Remove protective cover (1) and storage cap (6) from passive night viewer.

REMOVE PASSIVE NIGHT VIEWER

1. Turn MASTER SWITCH OFF.
2. Turn OFF operator's control switch (8).
3. Disconnect power cable (13) from passive night viewer and connect to storage bracket.
4. Unlock handle (12) and remove passive night viewer from bracket (11).
5. Install protective cover (1) and storage cap (6) on passive night viewer.
6. Install passive night viewer into storage box.

END OF TASK

OPERATE DRIVER'S VIEWER ENHANCER

0060 00

THIS WORK PACKAGE COVERS:

General Characteristics

INITIAL SETUP:

Tools and special Tools

Driver's Viewer Enhancer (item 67, Table 1, WP 0133 00)

References

TM 11-5855-311-12&P-1

The Driver's Viewer Enhancer is a through the hatch periscope for armored vehicles. The Driver's Viewer Enhancer enables the driver to drive at night under blackout conditions. It also can be used to observe around the vehicle at night. The DVE sensor assembly uses circuitry to increase brightness of low light levels. The DVE sensor assembly is connected by cable to the DVE viewer assembly inside the vehicle so the user can see a much brighter, green-colored picture of surrounding landscape. For operation, installation, removal and maintenance, refer to TM 11-5855-311-12&P-1. During daylight, and when not in use, the DVE sensor and viewer assemblies are stored in the case and strapped onto the hoist winch cable chute.

1. PROTECTIVE COVER
2. SENSOR ASSEMBLY
3. MOUNTING PLATE
4. VIEWER ASSEMBLY
5. OPERATOR'S CONTROL SWITCH PANEL
6. POWER CABLE
7. BRACKET
8. LOCKING HANDLE
9. QUICK-RELEASE PINS

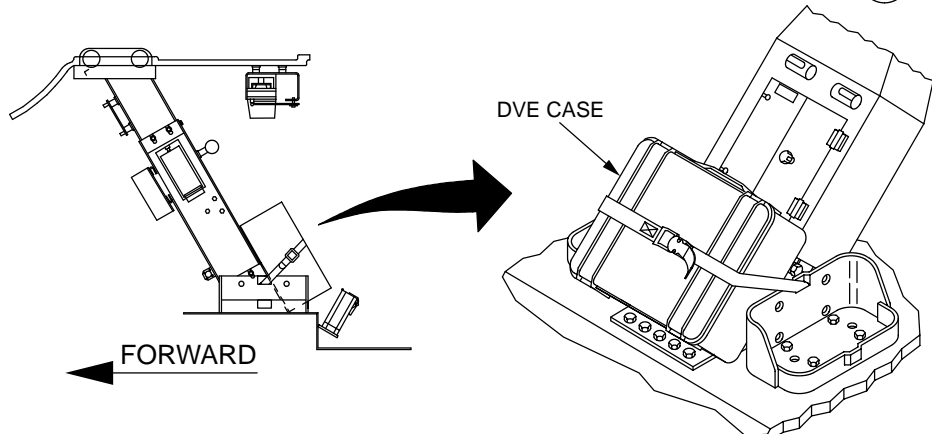
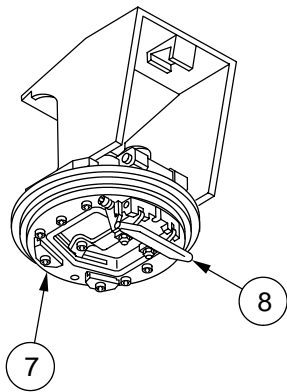
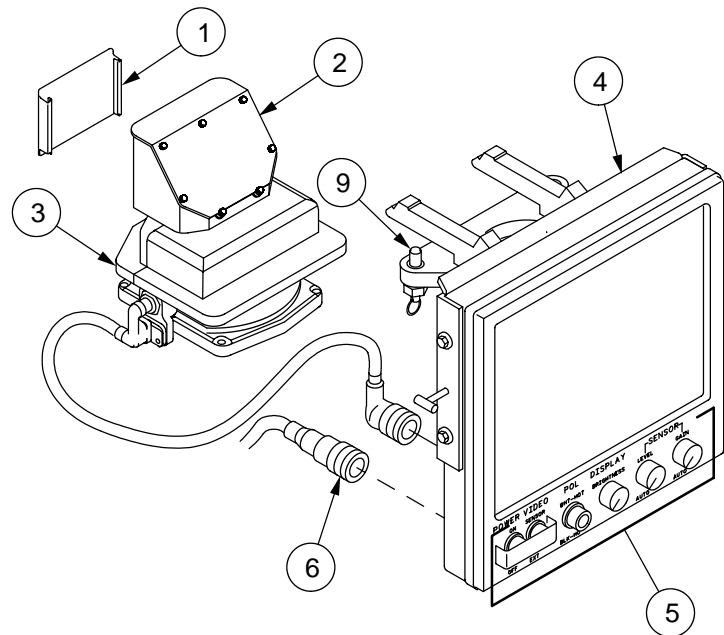

NOTE: IF DVE IS INSTALLED, SOME VEHICLES ARE EQUIPPED WITH ONLY ONE LIQUID CONTAINER AND BRACKET ASSEMBLY

33i114ma

OPERATE PORTABLE FIRE EXTINGUISHER**0061 00****THIS WORK PACKAGE COVERS:**

Operate Portable Fire Extinguishers

INITIAL SETUP:**Tools and special Tools**

Portable fire extinguishers (2) (item 12, Table 2, WP 0133 00)

References

WP 0133 00

Two portable fire extinguishers are located in the vehicle, one each on the right and left rear sides of the crew compartment. They contain carbon dioxide and are used to extinguish local fires inside or outside the vehicle.

WARNING

CO₂ fire extinguisher can cause suffocation and severe burns. Exit vehicle immediately after discharging fire extinguisher. Handle fire extinguisher carefully. Do not bang or drop the cylinder. Failure to comply may result in injury or DEATH to personnel.

1. Pull latch (1) and remove fire extinguisher from mounting bracket (2).
2. Pull safety pin (3).
3. Point cone (4) at base of fire.
4. Squeeze handle (5).

WARNING

Do not touch cone when using fire extinguisher. Hands may be severely burned. Failure to comply may result in injury to personnel.

5. Exit vehicle immediately after discharging fire extinguisher.
6. Have unit maintenance replace discharged fire extinguishers.

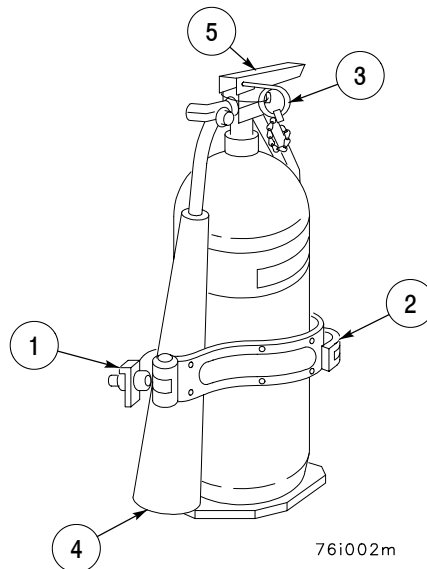
**END OF TASK**

OPERATE FIXED FIRE EXTINGUISHER SYSTEM (FES).**0062 00****THIS WORK PACKAGE COVERS:**

Releasing CO₂ Using Inside Pull Handles, Releasing CO₂ Using Outside Pull Handles, Releasing CO₂ Using Manual Discharge Handles

The fire extinguisher system (FES) contains two banks of four cylinders each. Each bank discharges CO₂ into engine and hydraulic compartments. The FES will put out electrical, hydraulic, and fuel type fires. Two sets of pull handles are used to discharge the FES. One set is located inside crew compartment on left hand wall behind the driver. The other set is located outside, on left hand side of vehicle. Each handle in a set of pull handles will discharge one of the banks of cylinders. In addition to two sets of pull handles, there are manual discharge levers on top of two rear left side cylinders. These levers may be used if pull handles malfunction or are not accessible.

WARNING

CO₂ fire extinguisher can cause suffocation and severe burns. Exit vehicle immediately after discharging fire extinguisher. Failure to comply may result in injury or DEATH to personnel.

RELEASING CO₂ WITH INSIDE PULL HANDLES

1. Remove quick-release pin (1), shield (2) will pivot down exposing handles (3) and release push button switch (4). This action activates the engine fuel shutoff solenoid and shuts the main engine OFF. Also, the fire extinguisher shutoff light (5) is illuminated on gauge panel (6).
2. Grab one handle (3) and pull hard. If fire is intense or an explosion is possible, grab both handles, pull hard and get away fast.
3. If only one handle was pulled, and fire was not extinguished, pull second handle hard to release the second bank of cylinders.
4. Exit vehicle immediately after discharging fire extinguisher.

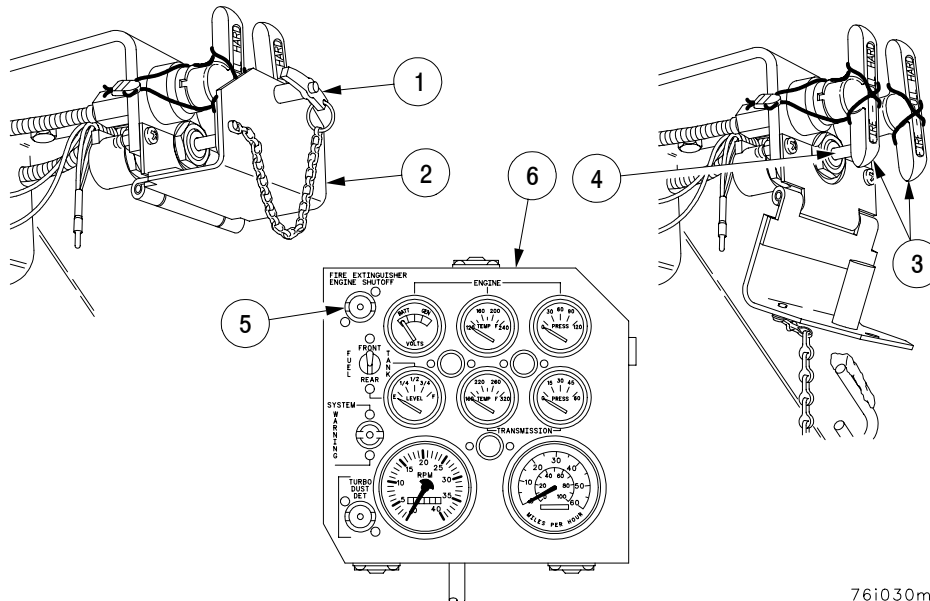

76i030m

OPERATE FIXED FIRE EXTINGUISHER SYSTEM (FES) - CONTINUED**0062 00****RELEASING CO₂ USING OUTSIDE PULL HANDLES**

1. Grab one handle (7) and pull hard. If fire is intense or an explosion is possible, grab both handles, pull hard and get away fast.
2. If only one handle was pulled, and fire was not extinguished, pull second handle hard to release the second bank of cylinders.
3. Do not enter vehicle after fire extinguisher has been discharged.

RELEASING CO₂ USING MANUAL DISCHARGE LEVERS

1. Pull locking pin(s) (8).
2. Push lever (9) on one cylinder forward to discharge one bank. Push both levers forward on both cylinders to discharge both banks.
3. Exit vehicle immediately after discharging fire extinguisher.

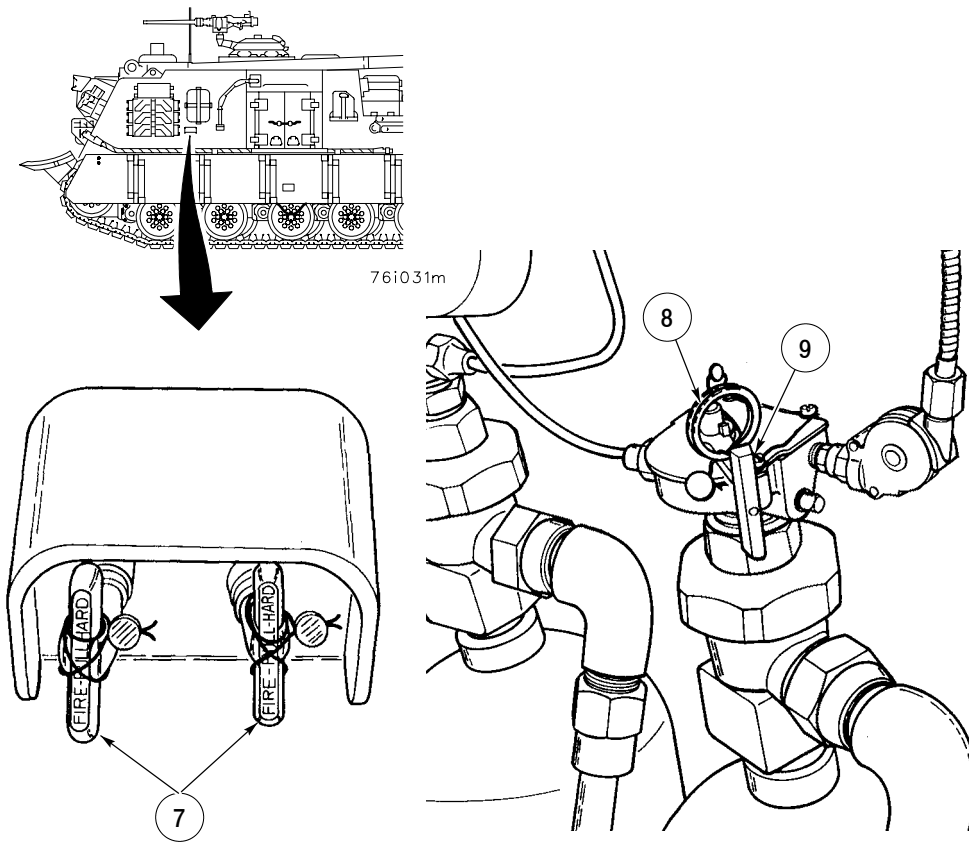
**END OF TASK**

OPERATE VEHICLE JACK

0063 00**THIS WORK PACKAGE COVERS:**Operate Vehicle Jack

INITIAL SETUP:**Tools and special Tools**

30-ton hydraulic jack (item 20, Table 2, WP 0133 00)

ReferencesWP 0133 00

A 30-ton hydraulic jack is carried on the vehicle stowed in the rear deck stowage box.

1. Turn valve (1) to right (closed) before using jack.
2. Place jack on hard, level ground.
3. Join two-piece handle (2) together and insert into jack.
4. Pump handle up and down to raise jack.
5. To lower, unscrew valve (1) slowly and allow jack to lower slowly.

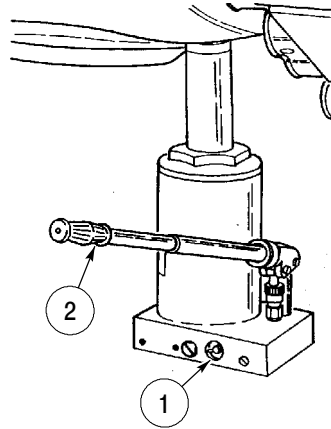
**END OF TASK**

OPERATE OUTSIDE SPOTLIGHT**0064 00****THIS WORK PACKAGE COVERS:**

Operate Outside Spotlight

1. Turn MASTER switch ON.
2. Push light switch (1) up to turn light ON.
3. Rotate control mast (2) to turn spotlight 360° with handle (3).
4. Turn handle (3) to raise or lower the pointing angle.
5. Push light switch (1) down to turn light OFF.

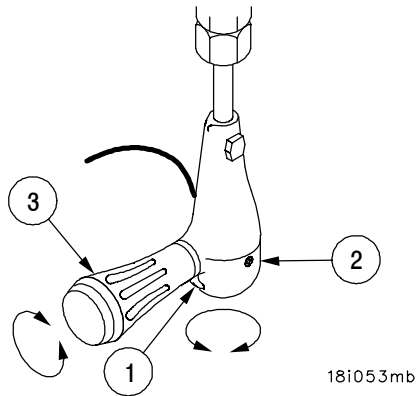
**END OF TASK**

OPERATE TROUBLE LIGHT**0065 00****THIS WORK PACKAGE COVERS:**

Operate Trouble Light

1. Turn Master switch ON.
2. Turn FUEL PUMP switch OFF.
3. Loosen knurled head screw (1), to remove trouble light from mounting bracket (2).
4. Press ON-OFF switch (3) on hand grip, to turn light ON.
5. Press ON-OFF switch again, to turn light OFF.
6. Turn knurled knob (4) to activate cable lock to hold cable in the deployed position during use.

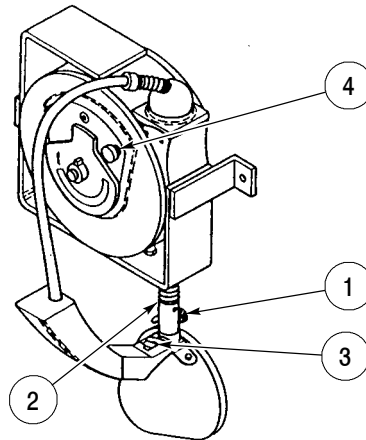
**END OF TASK**

OPERATE WELDING EQUIPMENT (ACETYLENE/OXYGEN)**0066 00****THIS WORK PACKAGE COVERS:**

Installing Oxygen Cylinder Regulator Valve, Removing Oxygen Cylinder Regulator Valve, Installing Acetylene Cylinder Regulator Valve, Removing Acetylene Cylinder Regulator Valve

INITIAL SETUP:**Tools and Special Tools**

Oxygen compressed gas pressure regulator (item 37, Table 1, WP 0133 00)
 Acetylene compressed gas pressure regulator (item 36, Table 1, WP 0133 00)
 Oxygen compressed gas cylinder (item 14, Table 1, WP 0133 00)
 Acetylene compressed gas cylinder (item 15, Table 1, WP 0133 00)
 Cutting torch set (item 44, Table 1, WP 0133 00)
 Flint-tip friction igniter w/holder (item 16, Table 1, WP 0133 00)
 Igniter (item 25, Table 1, WP 0133 00)
 Acetylene gas hose w/coupling (item 21, Table 1, WP 0133 00)
 Oxygen gas hose w/coupling (item 22, Table 1, WP 0133 00)
 Leather welding gloves (item 18, Table 1, WP 0133 00)
 Industrial welding goggles (item 19, Table 1, WP 0133 00)
 Adjustable wrench (item 41, Table 2, WP 0133 00)

References

WP 0133 00

The welding equipment consists of an oxygen cylinder, acetylene cylinder, oxygen regulator, acetylene regulator, hoses, torch set, leather gloves, ignitor with flints, and welding goggles.

WARNING

Oxygen gas is stored under extremely high pressure. Ensure protective cap is in place when cylinder is not in use. If head of cylinder is broken off personnel may be injured or killed.

CAUTION

Oxygen cylinder and regulator valve are equipped with right hand threads. Do not turn in wrong direction when removing or damage may occur to the equipment.

OPERATE WELDING EQUIPMENT (ACETYLENE/OXYGEN) - CONTINUED**0066 00****INSTALLING OXYGEN CYLINDER REGULATOR VALVE**

1. Remove quick-release pin (1) and open guard (2).
2. Remove protective cap (3).
3. Position regulator valve (4) so gauges can be read easily.
4. Align regulator valve (4) and tighten nut (5).

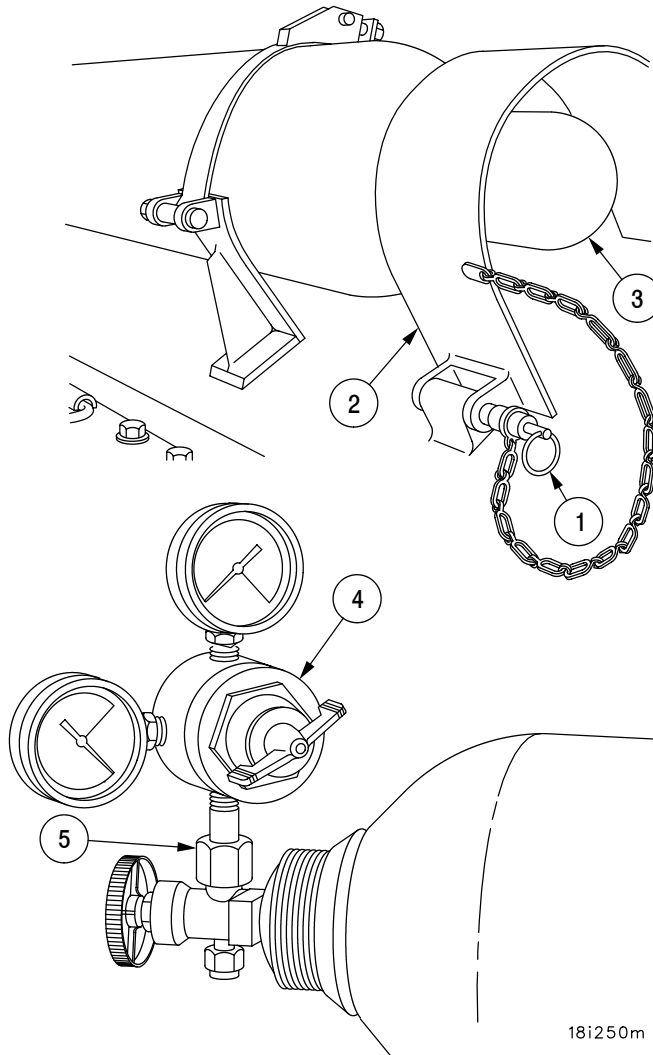

WARNING

Ensure oxygen bottle valve is turned off and regulator gauges read 0 psi before removing regulator valve. Oxygen is under high pressure and could cause serious injury or DEATH to personnel.

REMOVING OXYGEN CYLINDER REGULATOR VALVE

1. Loosen nut (5) and remove regulator valve (4).
2. Install protective cap (3).
3. Close guard (2) and install quick-release pin (1).

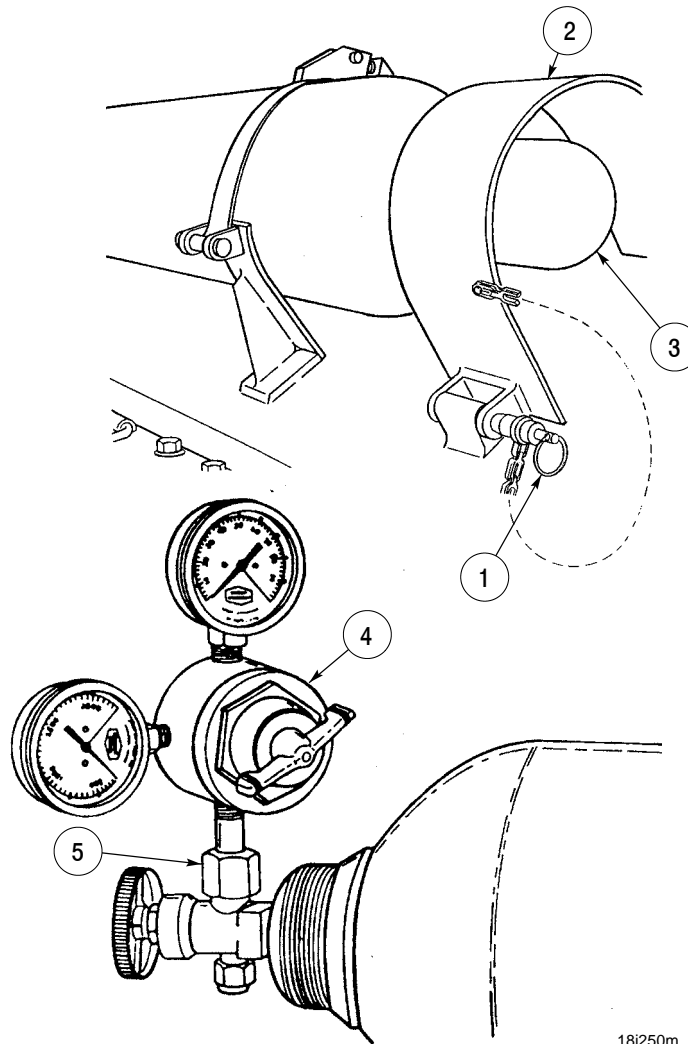

INSTALLING ACETYLENE CYLINDER REGULATOR VALVE**WARNING**

Acetylene gas is stored under extremely high pressure. Ensure protective cap is in place when cylinder is not in use. If head of cylinder is broken off personnel may be injured or killed.

Acetylene gas is flammable. If cylinder leaks, notify unit maintenance. Do not attempt to use. Acetylene may explode causing injury or DEATH to personnel.

CAUTION

Acetylene cylinder and regulator valve are equipped with left hand threads. Do not turn in wrong direction when removing or damage may occur to the equipment.

1. Remove four screws (1), four lockwashers (2) and armor plate (3).
2. Remove hull outlet fitting plug (4).
3. Position regulator valve (5) so gauges can be easily read.
4. Tighten nut (6).

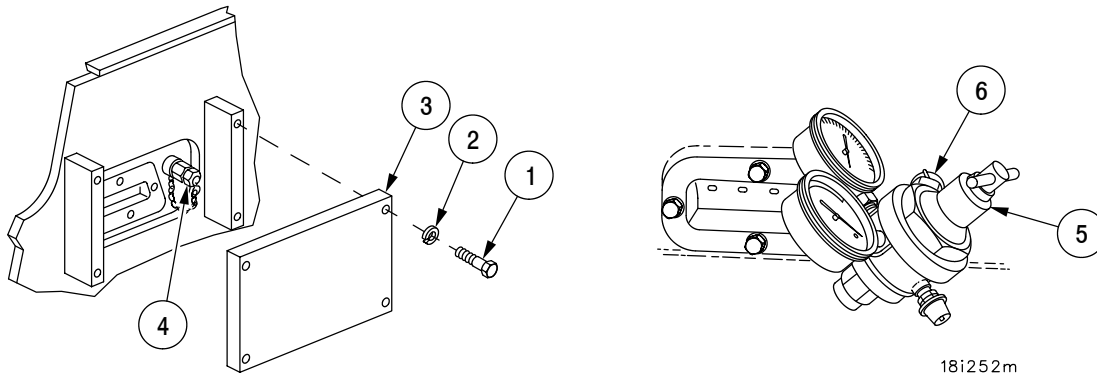
**REMOVING ACETYLENE CYLINDER REGULATOR VALVE****WARNING**

Ensure acetylene bottle valve is turned off before removing regulator valve. Acetylene is under high pressure and could cause serious injury or DEATH to personnel.

1. Loosen nut (6) and remove regulator valve (5).
2. Install hull outlet fitting plug (4).
3. Install armor plate (3) with four lockwashers (2) and four screws (1).

END OF TASK

OPERATE WELDING EQUIPMENT (EXOTHERMIC CUTTER)

0067 00**THIS WORK PACKAGE COVERS:**

Installing Oxygen Cylinder Regulator Valve, Connecting Exothermic Cutter, Disconnecting Exothermic Cutter, Removing Oxygen Cylinder Regulator Valve

INITIAL SETUP:**Tools and Special Tools**

Exothermic cutter
Oxygen compressed gas pressure regulator (item 37, Table 1, WP 0133 00)
Oxygen compressed gas cylinder (item 14, Table 1, WP 0133 00)
Flint-tip friction igniter w/holder (item 16, Table 1, WP 0133 00)
Igniter (item 25, Table 1, WP 0133 00)
Oxygen gas hose w/coupling (item 22, Table 1, WP 0133 00)
Leather welding gloves (item 18, Table 1, WP 0133 00)
Industrial welding goggles (item 19, Table 1, WP 0133 00)
Adjustable wrench (item 41, Table 2, WP 0133 00)

References

WP 0133 00

The welding equipment consists of an oxygen cylinder, exothermic cutter, oxygen regulator, leather gloves, ignitor with flints, and welding goggles.

WARNING

Oxygen gas is stored under extremely high pressure. Ensure protective cap is in place when cylinder is not in use. If head of cylinder is broken off, personnel may be injured or killed.

WARNING

To reduce the risk of injury in the unlikely event of regulator failure, never stand directly in front or directly behind the oxygen regulator while opening the oxygen cylinder valve.

WARNING

Always make sure the oxygen cylinder is a safe distance from the immediate work area. To reduce the risk of injury due to an explosion, never let spark or molten material come in contact with the oxygen.

CAUTION

Oxygen cylinder and regulator valve are equipped with right hand threads. Do not turn in wrong direction when removing or damage may occur to the equipment.

WARNING

Always use a # 5 shade welding filter lens when cutting or observing cutting to protect your eyes from arc rays. Always wear safety glasses with side shields when in welding area to protect from spark. Always keep your head away from fumes plume. Welding fumes and gases may be hazardous to your health.

WARNING

Never lay cutter on top of the work or place it where it can accidentally contact the work or ground or other metal that contact the work or ground. Electric arc or overheating may result in shock or fire hazard.

WARNING

Always insulate yourself from the work and ground using dry insulation large enough to cover the full area of physical contact with work and ground.

WARNING

In addition to the above stated warnings, all warnings and cautions provided in the manufactures operational instruction guide must be strictly adhered too. Failure to comply with these warnings or cautions could result in injury, death or damage to the equipment.

INSTALLING OXYGEN CYLINDER REGULATOR VALVE**NOTE**

Some vehicles are equipped with a portable oxygen bottle stored inside the vehicle and performance of step 1 is not Required.

1. Remove quick-release pin (1) and open guard (2).
2. Remove protective cap (3).
3. Position regulator valve (4) so gauges can be read easily.
4. Align regulator valve (4) and tighten nut (5).

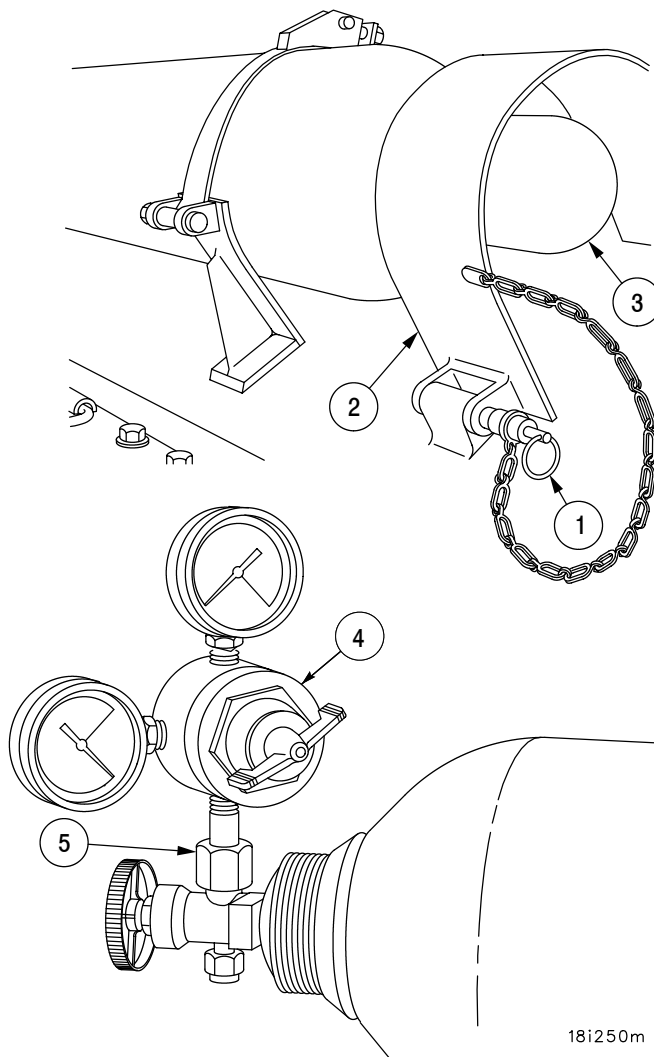

18i250m

CONNECTING EXOTHERMIC CUTTER

1. Open oxygen cylinder valve (6).
2. Open regulator valve (4) slightly to remove debris, close oxygen cylinder valve (6) and regulator valve (4).
3. Connect the oxygen hose (7) and exothermic cutter (8) to regulator valve (4).
4. Position the regulator valve (4) so gauges can be read easily.
5. Open the oxygen cylinder (6) and regulator valve (4) between 10 and 80 psi, depending on the target material and the type of work being performed. See table below for recommended settings.
6. Check all connections for oxygen leaks.

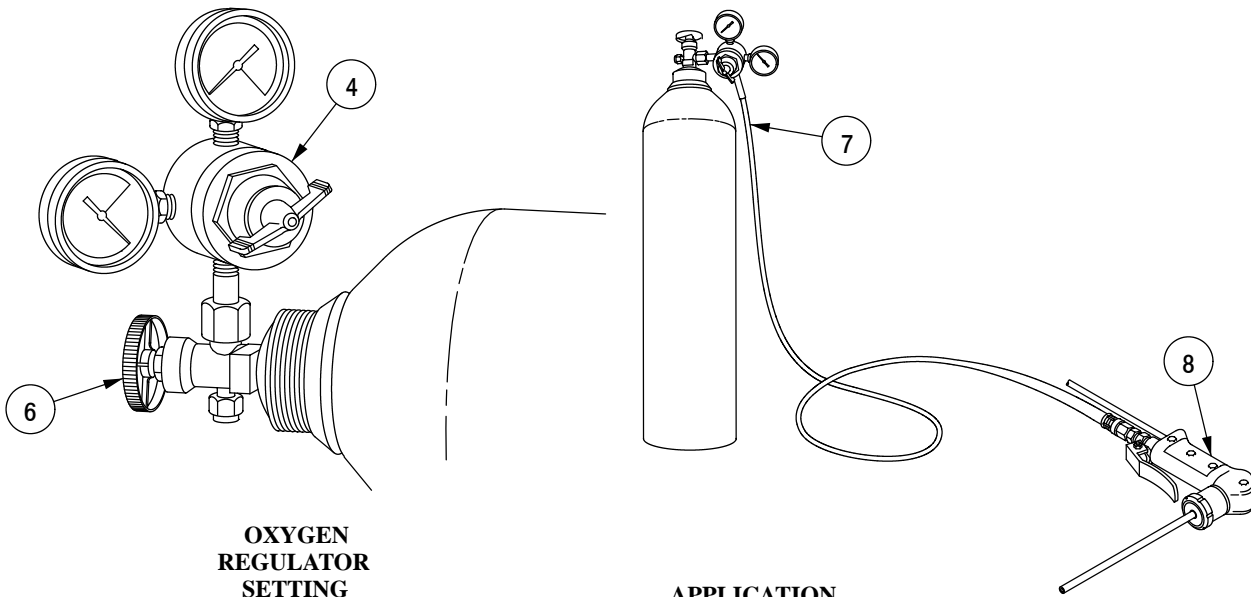

OXYGEN REGULATOR SETTING	APPLICATION
10-20 PSI	Piercing through hardplate
20-30 PSI	Cutting thin metal - up to 1/4" thick Piercing small bolts
30-40 PSI	Precision gouging Removal of bucket and cutter teeth Melting concrete and rock Piercing pins up to 4" in length Cutting iron and mild steel to 1/2" thick
40-50 PSI	Gouging Removing hardfacing and welds Melting concrete and rock Piercing pins over 4" in length Cutting non-ferrous material up to 1" thick Cutting mild steel 1/2"-1" thick
50-60 PSI	Cutting non-ferrous material up to 2" thick Cutting mild steel up to 2" thick
60-80 PSI	Cutting all metals over 2" thick

Suggested oxygen regulator pressure settings for Prime Cut systems.

18i361mb

OPERATE WELDING EQUIPMENT (EXOTHERMIC CUTTER) - CONTINUED**0067 00****CONNECTING EXOTHERMIC CUTTER - CONTINUED**

1. Open battery box door (WP 0035 00) if vehicle battery power is to be used.

NOTE

Some exothermic cutters may be equipped with a battery pack, if using a battery pack or connecting directly to the vehicle batteries follow instructions in user's guide provided with the equipment.

2. Install NATO slave receptacle adapter (9) in NATO slave receptacle (10).
3. Connect cable (11) (provided with equipment) to the NATO slave receptacle adapter (9), battery pack or vehicle batteries.
4. Load the cutting rod (follow user's guide provided with equipment).
5. Check to see that the selected contact tip is the appropriate size for the cutting rod being used.
6. Connect the exothermic cutter cable (12) black end to black end of cable (11).
7. Connect red end of striker plate cable (13) to red end of cable (11).
8. To operate and shutdown exothermic cutter follow user's guide provided with exothermic cutter.

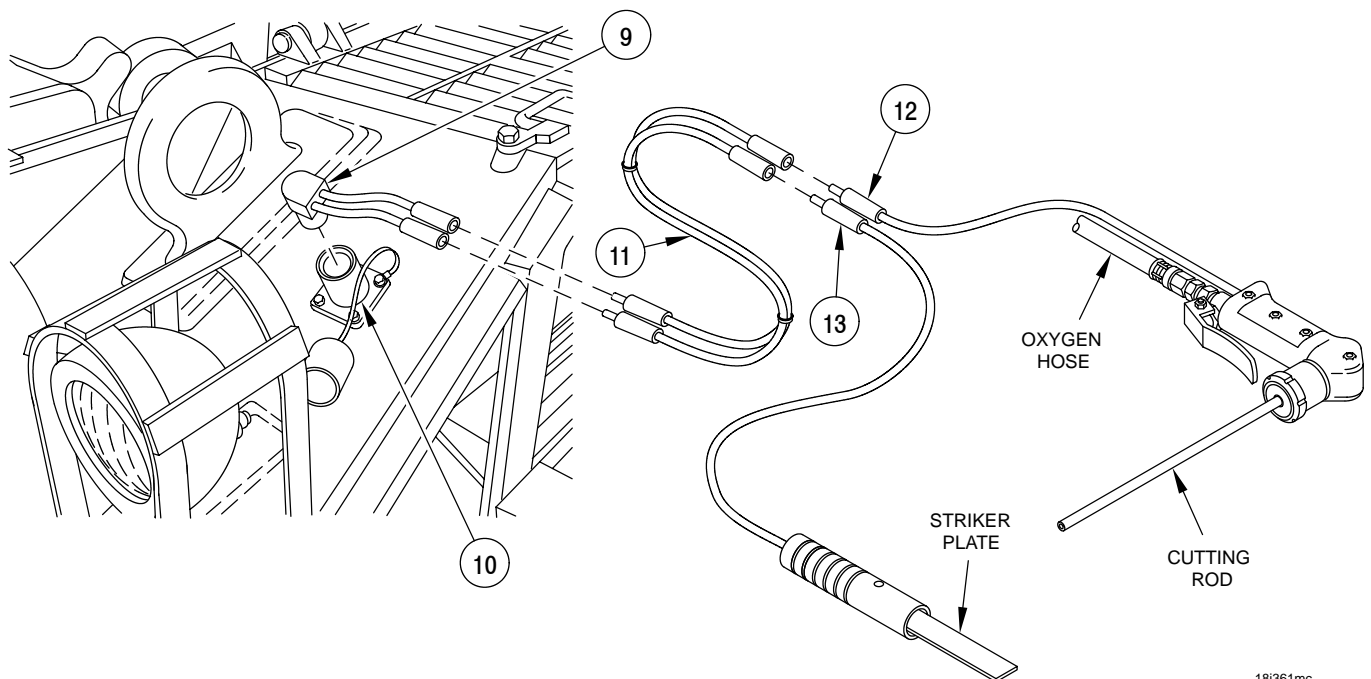

18/361mc

OPERATE WELDING EQUIPMENT (EXOTHERMIC CUTTER) - CONTINUED**0067 00****DISCONNECTING EXOTHERMIC CUTTER**

1. Disconnect red end of cable (11) from striker plate cable (13).
2. Disconnect black end of cable (11) from black end exothermic cutter cable (12).
3. Disconnect cable (11) from NATO slave receptacle adapter (9), battery pack or vehicle batteries.
4. Remove NATO slave receptacle adapter (9) from NATO slave receptacle (10).
5. Close battery box if vehicle batteries were used (WP 0035 00).
6. Close oxygen cylinder valve (6).
7. Set regulator valve (4) to 0 psi.
8. Disconnect oxygen hose (7) from regulator (4) and exothermic cutter (8).

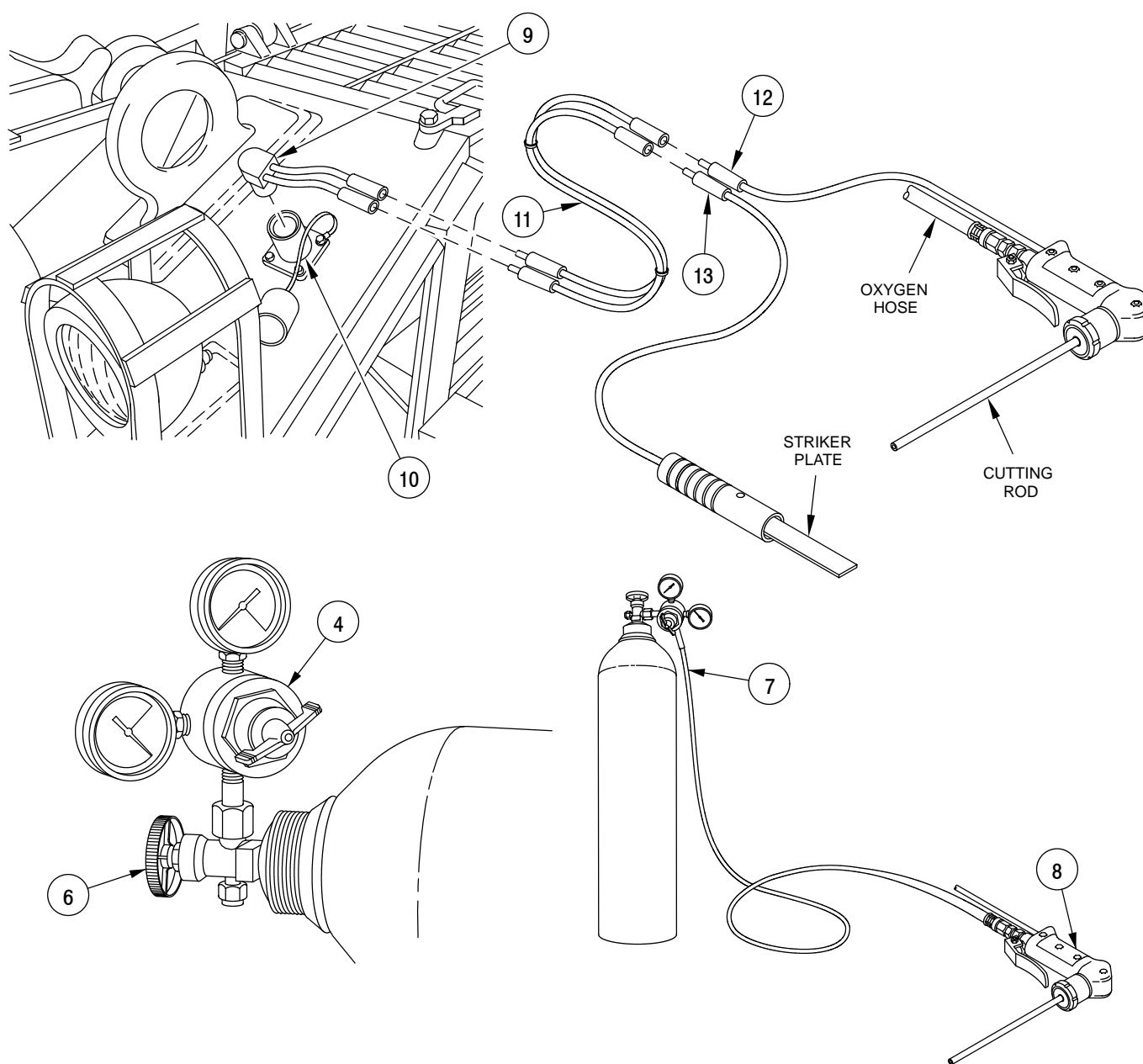

18i361md

REMOVING OXYGEN CYLINDER REGULATOR VALVE**WARNING**

Ensure oxygen bottle valve is turned off and regulator gauges read 0 psi before removing regulator valve. Oxygen is under high pressure and could cause serious injury or DEATH to personnel.

1. Loosen nut (5) and remove regulator valve (4).
2. Install protective cap (3).
3. Close guard (2) and install quick-release pin (1).

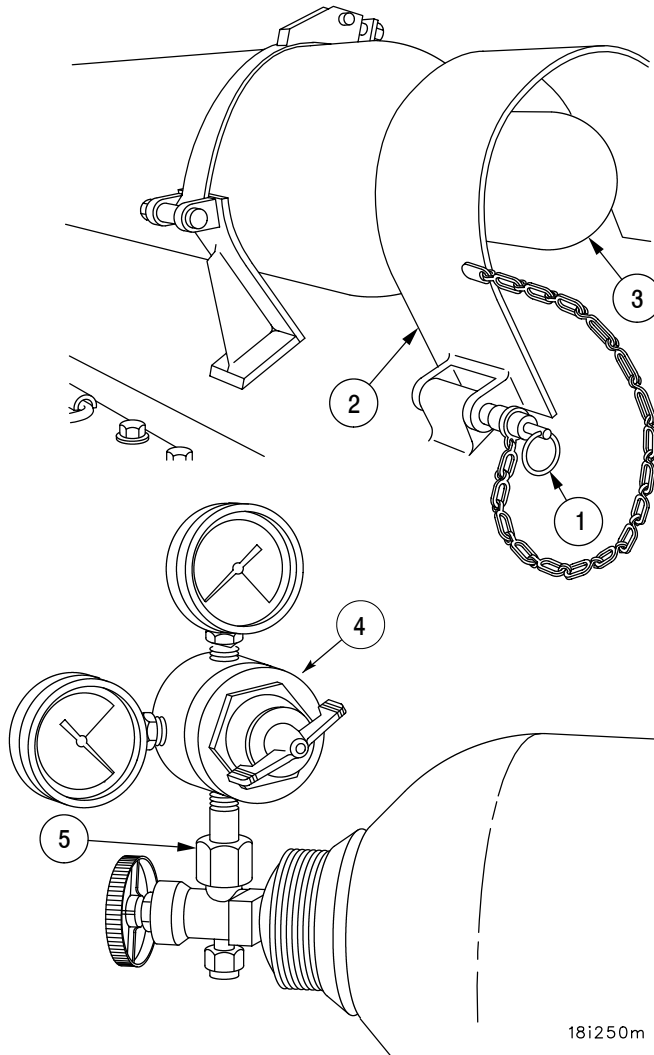

18i250m

OPERATE GAS-PARTICULATE FILTER UNIT AND M3 NBC HEATER

0068 00

THIS WORK PACKAGE COVERS:

Operate Gas Particulate Filter Unit and M3 NBC Heater

The M88A2 is equipped with two M2A2 gas-particulate filter units and three M3 NBC heaters. The operating switches for the filter units are located in the center of the vehicle, directly above the hoist winch chute. The operating switches for the M3 heaters are located on each heater.



WARNING

1. Turn MASTER switch (1) ON.
2. Put face mask on and adjust for proper fit.

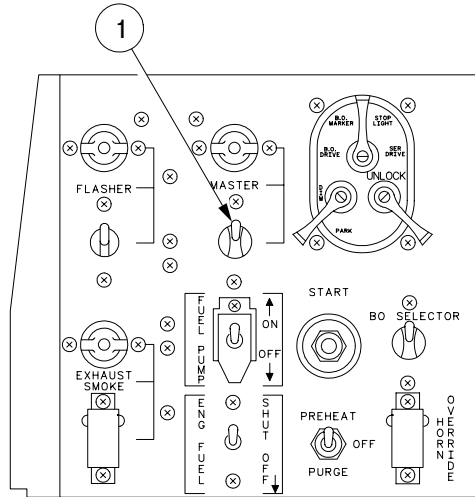

06i005mh

OPERATE GAS-PARTICULATE FILTER UNIT AND M3 NBC HEATER - CONTINUED

0068 00

3. Move spring clip (2) down to open air inlet holes.
4. Move AIR PURIFIER SWITCH (3) to ON.
5. Attach hoses (4) from M3 heater outlets to masks.
6. When necessary during NBC operations, turn ON M3 heater switch (5) to warm the air coming from gas particulate filter unit.
7. When finished with filter unit, uncouple hoses (4) from masks.
8. Remove masks from face.
9. Move AIR PURIFIER SWITCH (3) to OFF.
10. Stow masks and hoses.
11. Move spring clip (2) up to cover the holes.

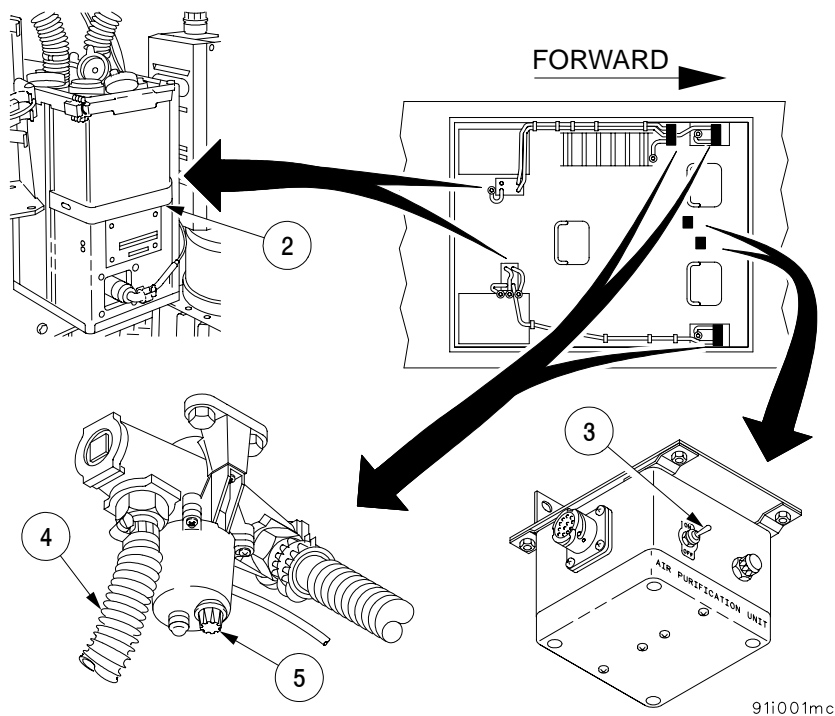

911001mc

END OF TASK

OPERATE CALIBER .50 MACHINE GUN MOUNT

0069 00**THIS WORK PACKAGE COVERS:**Operate .50 Caliber Machine Gun Mount

INITIAL SETUP:**References**

TM 9-1005-213-10

FM 23-65

WP 0127 00

Mount or dismount the .50 caliber machine gun per instructions in WP 0127 00. To allow the machine gun mount to move, pull lock pin (1) and loosen lock screw (2). This will allow the machine gun to swing and elevate. Refer to FM 23-65 and TM 9-1005-213-10 for instructions on how to operate and maintain the .50 caliber machine gun.

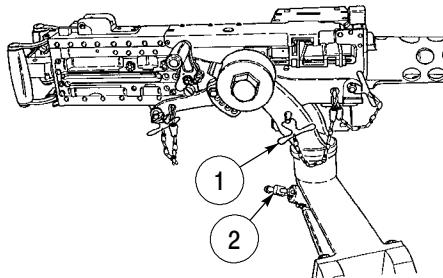
**END OF TASK**

OPERATE COMMUNICATIONS SYSTEM

0070 00**THIS WORK PACKAGE COVERS:**Operate Communications System

INITIAL SETUP:**References**

TM 11-5830-340-12
TM 11-5830-263-10
TM 11-5820-890-10-1
TM 11-5820-890-10-2

The communications equipment installed in the M88A2 is for internal and external communications. The internal communications system consists of the intercommunications set AN/VIC-1(V) (refer to TM 11-5830-340-12 for operation) or the AN/VIC-3(V) (refer to TM 11-5830-263-10 for operation). Both intercommunication sets provide communication between crew during operations. External communications will be provided by radio set: AN/VRC-90A (refer to TM 11-5820-890-10-1 or TM 11-5820-890-10-2 for operation).

END OF TASK

OPERATE M239 SMOKE GRENADE SYSTEM

0071 00**THIS WORK PACKAGE COVERS:**Loading, Firing, Reloading, Unloading, Duds and Misfires

INITIAL SETUP:**References**TM 9-1185-41

LOADING**WARNING**

Do not fire grenades when personnel are outside the vehicle. Grenades contain Red Phosphorous that constitutes a fire hazard and danger to all personnel outside the vehicle. Fire grenades only when all hatches are closed. Failure to comply may result in injury to personnel.

Ensure that the arming switch is OFF (lamp not lit) before loading grenades into a discharger. Failure to comply may result in firing grenades accidentally causing injury or DEATH to personnel.

Never place body in front of dischargers when loading grenades or when dischargers are unloaded/loaded. Failure to comply may result in injury or DEATH to personnel due to accidental discharge.

Follow standard weapon loading procedures when handling and loading grenades. Failure to comply may result in injury or DEATH to personnel due to accidental discharge.

OPERATE M239 SMOKE GRENADE SYSTEM - CONTINUED

0071 00

LOADING - CONTINUED

1. Ensure that arming switch (1) is OFF.
2. Remove canvas covers (2) and check that discharger barrels (3) are clear and clean.
3. Remove grenades (4) from six ammunition storage boxes (5).
4. Place grenades (4) into each ammunition storage bin (6) on each side of the hull until mission requires loading in discharge barrels.

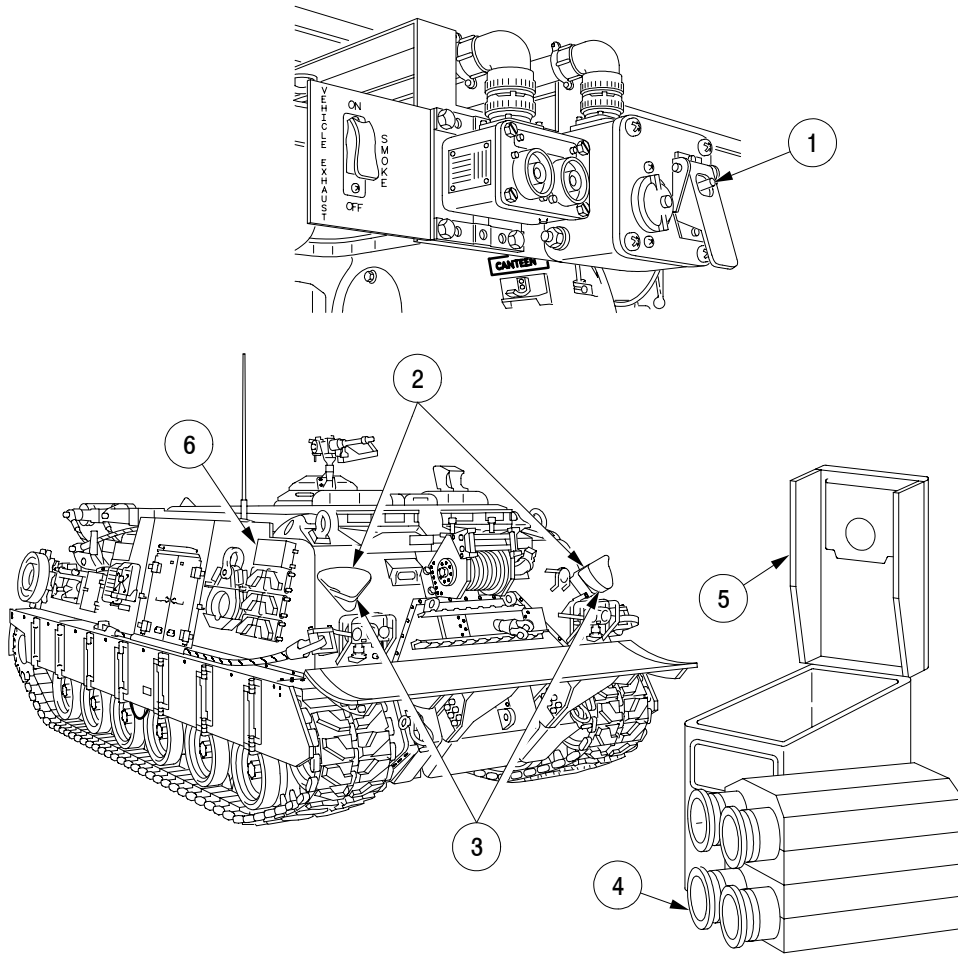

18i071m

OPERATE M239 SMOKE GRENADE SYSTEM - CONTINUED**0071 00****LOADING - CONTINUED**

5. Load six grenades (4) in each discharger (3). Insert grenades, base first, into barrel. Push hard on top of grenade with palm of hand while rotating grenade 1/4 to 1/2 turn. This will ensure that the spring clip (7) at the base of the grenade is engaged on pin in bottom of barrel of discharger and assure electrical contact.

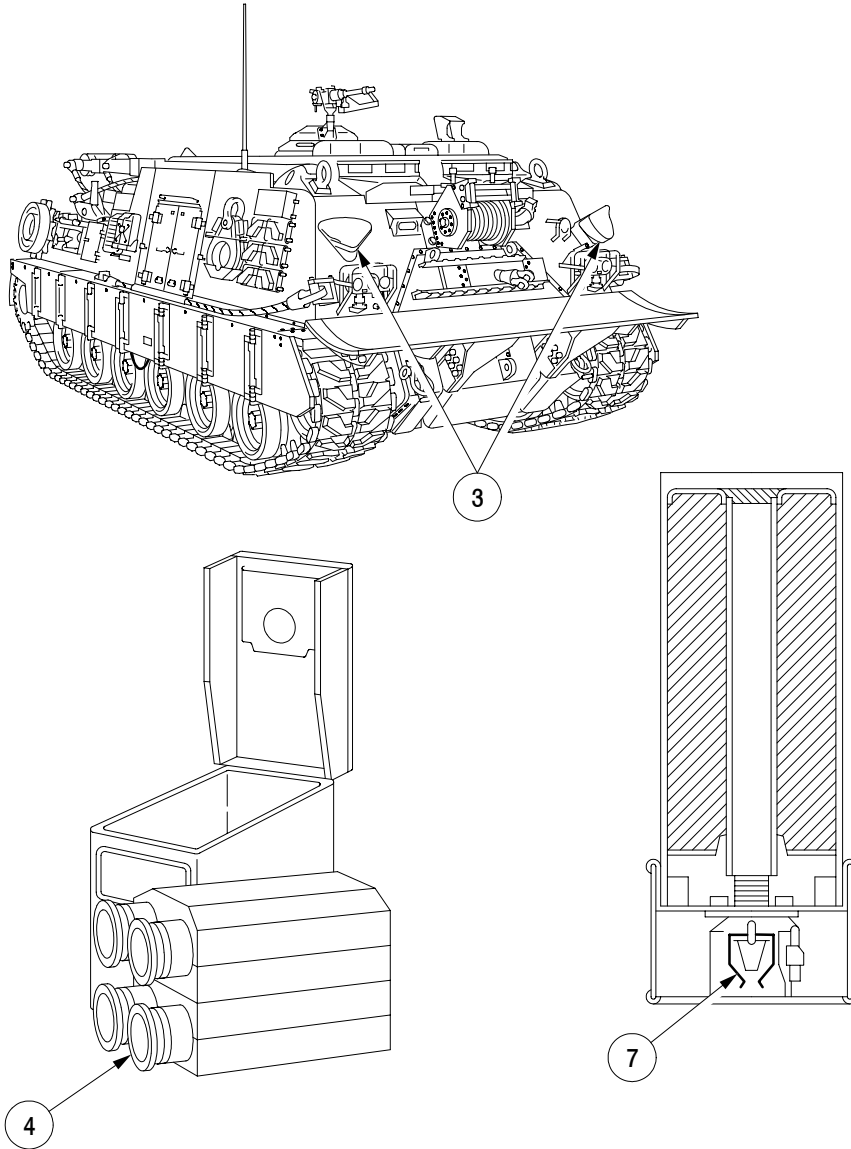

18i071mc

OPERATE M239 SMOKE GRENADE SYSTEM - CONTINUED

0071 00

RELOADING - CONTINUED

2. Turn MASTER switch (8) OFF.
3. Check that all barrels of discharger (3) are clear.
4. If grenades (4) are still in dischargers (3), refer to Duds and Misfires and unloading procedures located in this work package.
5. Reload discharger (3) barrels with grenades (4) from the two grenade stowage boxes (6).

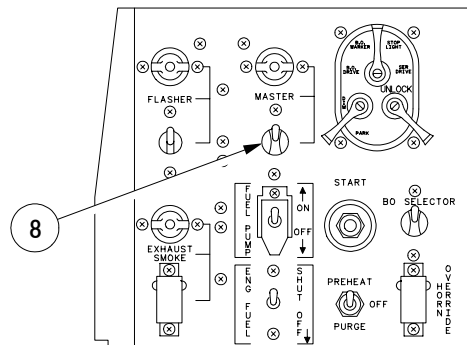
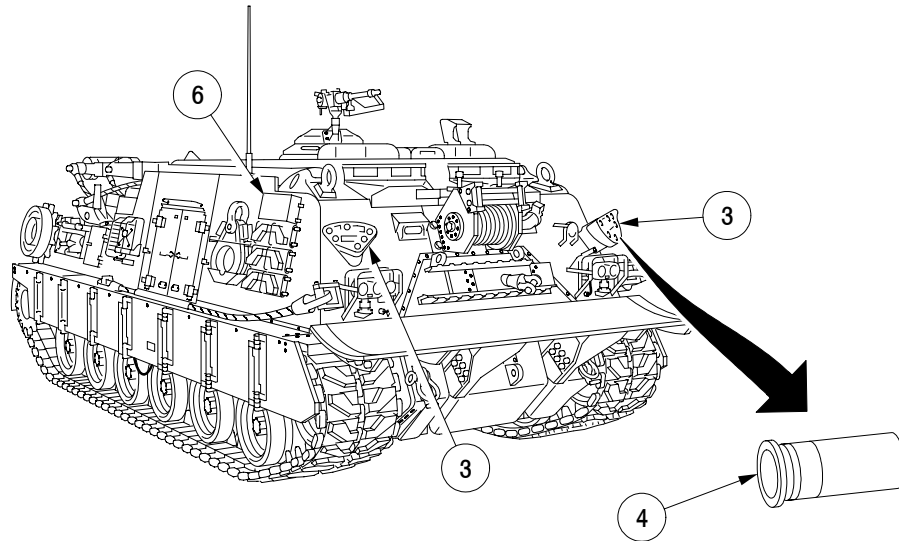

18:071ma

OPERATE M239 SMOKE GRENADE SYSTEM - CONTINUED**0071 00****UNLOADING****WARNING**

Ensure that arming switch is OFF (lamp not lit) before loading or unloading grenades from discharger. Failure to comply may result in injury or DEATH to personnel due to accidental discharge.

Never place body in front of dischargers when loading or unloading grenades or when dischargers are loaded. Failure to comply may result in injury or DEATH to personnel due to accidental discharge.

1. Remove grenades (4) from discharger (3) by pulling grenade (4) out with hands.
2. Return grenades (4) to metal ammunition storage boxes (6) on side of hull.
3. Install canvas covers (2) over dischargers (3) to keep out debris.

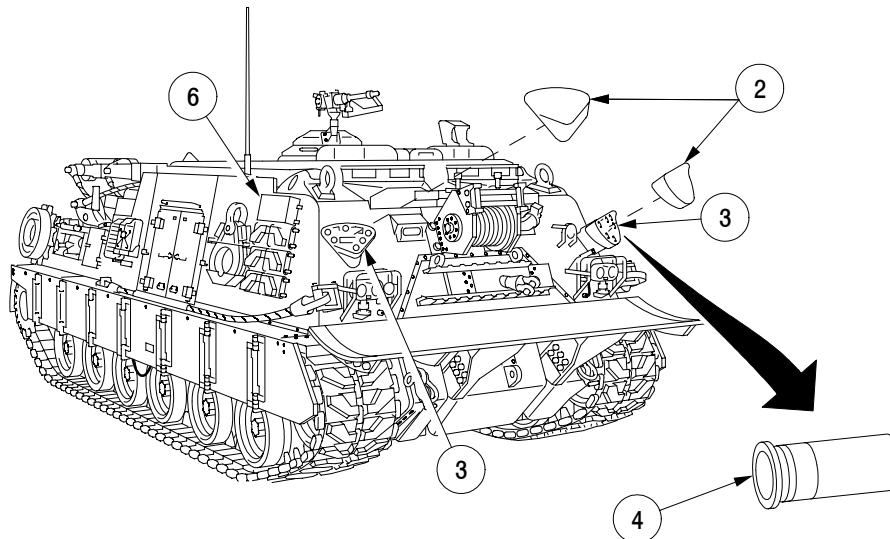

18i071mb

DUDS AND MISFIRES

1. Misfire. A misfire is the failure of the grenade to be launched from discharger. When a misfire occurs, make two additional attempts to fire grenade in accordance with this work package. If grenade still remains, remove grenade in accordance with this work package and attempt to fire grenade from another discharger barrel. If grenade still remains, treat as a dud.
2. Duds. A dud is a grenade that has either failed to be launched from discharger or has been launched but failed to burst. Remove dud from discharger barrel and place dud in an empty storage box as referenced in TM 9-1185-41 and dispose of in accordance with local Standard Operating Procedure (SOP). If a grenade has been launched but failed to burst, mark location and handle in accordance with local Standard Operating Procedures (SOP).

END OF TASK

OPERATE EXHAUST SMOKE GENERATING SYSTEM

0072 00

THIS WORK PACKAGE COVERS:

Operate Exhaust Smoke Generating System

INITIAL SETUP:

References

WP 0033 00

WP 0012 00

CAUTION

Always be sure of wind direction and speed when using smoke generator.

After initial operation, recheck the system for any possible fuel leaks.

Do not operate smoke generator if vehicle fuel supply is low.

Engine must run for a minimum of 5 minutes after smoke system is shut down to clear exhaust.

Failure to comply may result in damage to equipment.

NOTE

Exhaust Smoke Generating System will not produce smoke if vehicle is using JP-8 fuel.

1. Open engine deck grille door (1) (WP 0033 00).
2. Remove lockwire from exhaust smoke generator system manual fuel shutoff handle (2) and move handle to the ON position.
3. Close engine deck grille door (1).
4. Turn MASTER switch (3) ON.
5. Start main engine and warm it up (WP 0012 00).
6. Maintain an engine speed of at least 1600 rpm.

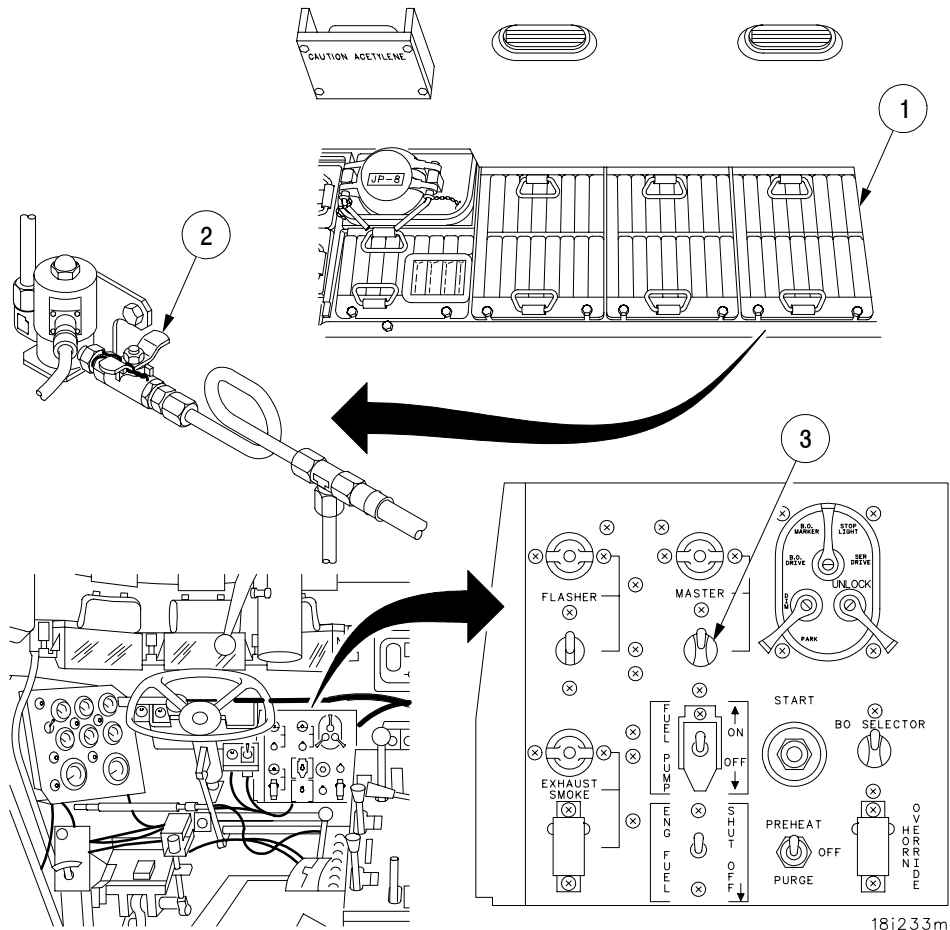

OPERATE EXHAUST SMOKE GENERATING SYSTEM - CONTINUED

0072 00

7. Activate smoke generating system by opening either operator's (4) or commander's (5) VEHICLE EXHAUST SMOKE switch guard and moving switch to ON position. The indicator (6) will light when system is activated.
8. To turn off the smoke generator, close the operator's (4) or commander's (5) switch guard on the VEHICLE EXHAUST SMOKE switch; this will move switch to OFF position. Open engine deck grille door (WP 0033 00), close manual fuel shutoff handle and install new lockwire.
9. Engine must run for at least 5 minutes to clear exhaust before main engine can be shut down and MASTER switch (3) turned OFF.

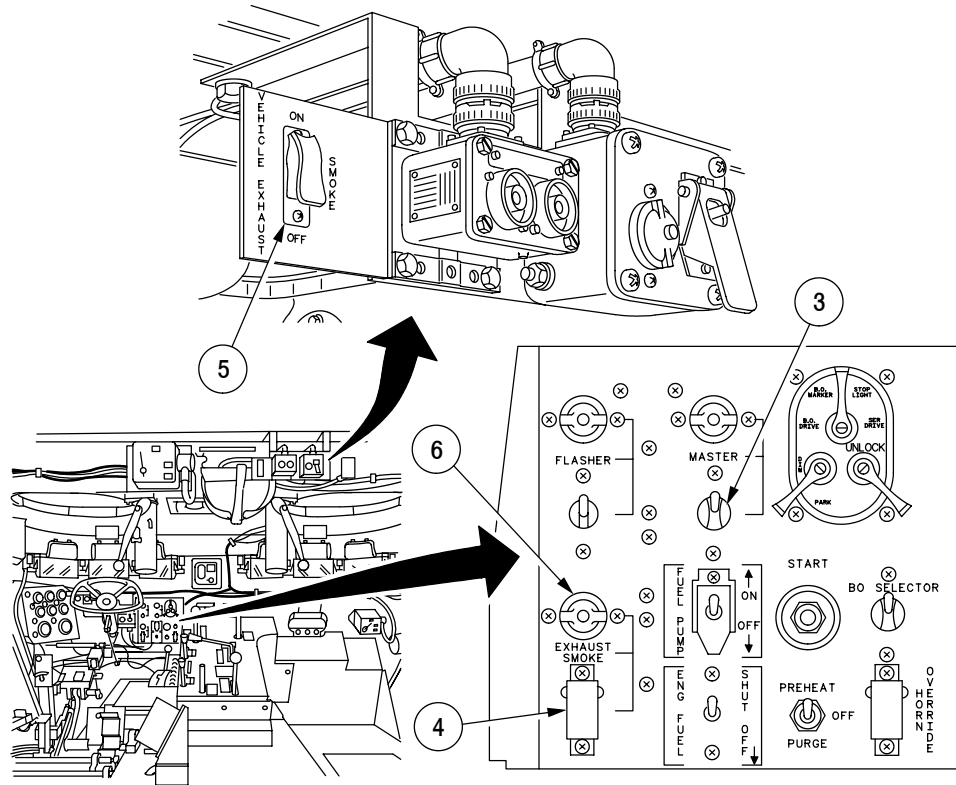

06i022m

END OF TASK

PREPARATION FOR MOVEMENT

0073 00**THIS WORK PACKAGE COVERS:**Preparation for Movement

INITIAL SETUP:**Personnel Required**

Three

References

WP 0046 00

WP 0047 00

WP 0048 00

WP 0049 00

WP 0050 00

WP 0105 00

1. Retrieve all cables (WP 0048 00, WP 0049 00 or WP 0050 00).
2. Lower boom and secure in travel lock position (WP 0047 00).
3. Strap down 35-ton hook block in boom tray (WP 0047 00).
4. Raise spade to locked position (WP 0046 00).
5. Stow all equipment in its proper stowage locations.
6. Close and secure all stowage compartment doors, access doors and access plates.
7. Perform all BEFORE-OPERATION PMCS tasks (WP 0105 00, Table 1).

END OF TASK

SLAVE START

0074 00

THIS WORK PACKAGE COVERS:

Slave Start

INITIAL SETUP:

Tools and Special Tools

Slave Cable Kit (item 21, Table 2, WP 0133 00)

Personnel Required

Three

References

- WP 0105 00
- WP 0133 00
- WP 0012 00
- WP 0013 00
- WP 0090 00
- WP 0077 00

If main engine does not start due to low or discharged batteries, it can be started with help of another vehicle. The M88A2 is equipped with an auxiliary power (NATO slave) receptacle and slave cable kit for slave starting.



Turn off radio and electrical switches before starting engine. Failure to comply may result in equipment damage due to electrical spike.

NOTE

- These instructions are for starting this vehicle or for slave starting disabled vehicle from this vehicle.
 - In this procedure, dead vehicle is disabled vehicle and live vehicle is vehicle doing the slaving.
1. Before slave starting main engine and driving vehicle, perform all BEFORE operation procedures in PMCS Table 1 (WP 0105 00).
 2. Turn MASTER switch OFF in dead vehicle.

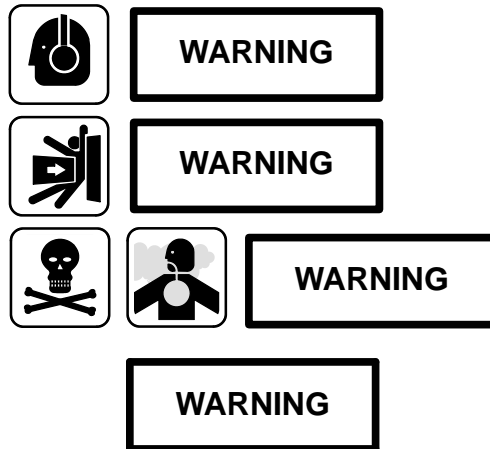

Do not leave the operator's seat while the engine is running. Failure to comply may result in accidental movement of vehicle causing injury or DEATH to personnel.

WARNING

During a slave start do not allow personnel to get between the two vehicles. Lock brakes on vehicles and reduce slaving vehicle engine speed to low idle (825 to 875 rpm). Failure to comply may result in injury or DEATH to personnel if vehicle moves.

3. Position a vehicle having a 24-volt, six-battery system near the dead vehicle so the auxiliary power receptacles are as close as possible. If live vehicle is an M60 series, M88 series, M1, M728, M48A3 or M48A5 keep the engine running.

NOTE

M60 series, M88 series, M109 series, M728, M48A3 and M48A5 vehicle engines will continue running with the MASTER switch OFF.

4. Turn MASTER switch OFF in live vehicle.
5. Connect slave cable to auxiliary power receptacle (1) on both vehicles.

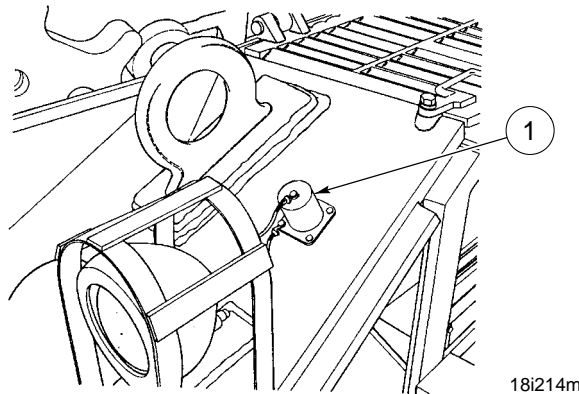

18i214m

6. Turn MASTER switch ON in live vehicle and charge dead vehicle's batteries for 20 minutes before trying to start main engine.
7. Turn MASTER switch OFF in live vehicle and ON in dead vehicle after charging period.

CAUTION

If dead vehicle does not start within 15 seconds, release START button and accelerator pedal. Turn MASTER switch OFF and wait three to five minutes. Repeat starting procedures. If engine does not start on sixth try, troubleshoot (refer to WP 0090 00 or dead vehicle's technical manual). Failure to comply will overheat the starter motor which may result in equipment damage.

8. Start main engine in dead vehicle (WP 0012 00). For cold weather starting, refer to WP 0077 00.
9. Turn MASTER switch OFF in dead vehicle and disconnect slave cable from both vehicles and stow.
10. Turn MASTER switch ON and check that BATT-GEN indicator points to the green area.
11. Check that engine is operating normally (WP 0013 00).
12. If engine runs roughly during warm-up, hold engine PREHEAT toggle switch (2) to PREHEAT until smooth engine operation returns. Release engine PREHEAT toggle switch (2) after engine runs smoothly.
13. If vehicle is not going to be driven for 30 minutes, idle the engine at 1,000 to 1,200 rpm for 30 minutes to recharge the batteries.

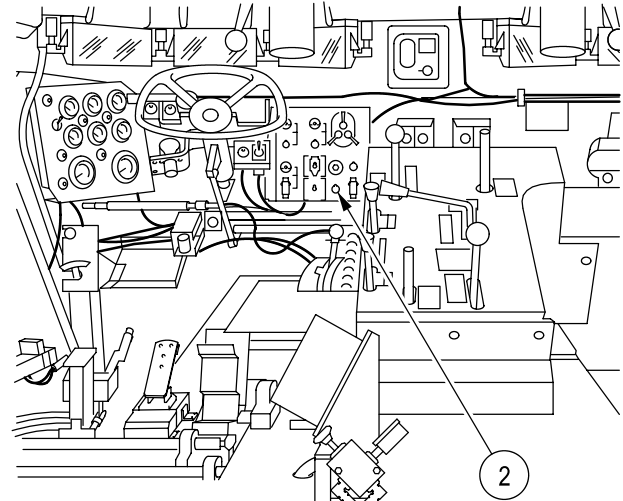
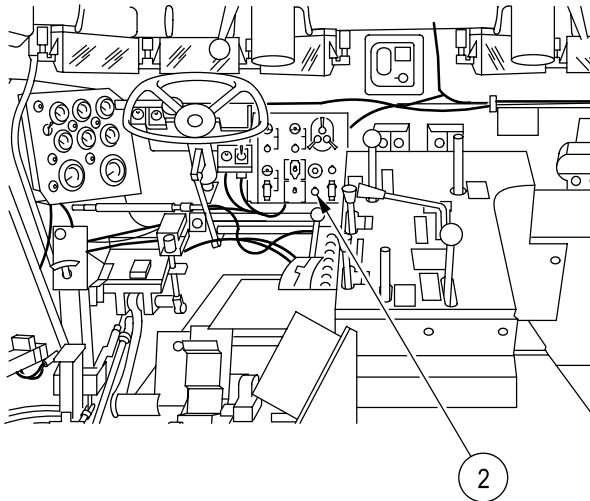

NEW CONFIGURATION
WITH BRAKE MODULATION AND
ENHANCED PARKING BRAKE

18i042mm

END OF TASK

TOWED START**0075 00****THIS WORK PACKAGE COVERS:**

Towed Start.

INITIAL SETUP:**Personnel Required**

Three

References

WP 0011 00
 WP 0012 00
 WP 0013 00
 WP 0077 00
 WP 0043 00
 WP 0090 00
 WP 0041 00
 WP 0105 00

1. Before starting main engine and driving vehicle, perform all BEFORE operation procedures in PMCS Table 1 (WP 0105 00).

Under normal conditions and on level terrain, main engine may be started by towing vehicle.

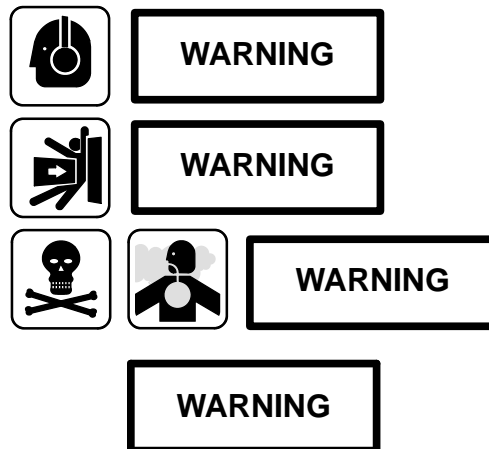

Do not leave the operator's seat while the engine is running. Failure to comply may result in accidental movement of vehicle causing injury or DEATH to personnel.

2. Prepare vehicle for towing with tow bar (WP 0043 00).
3. Perform prestart procedures (WP 0011 00).
4. If vehicle is equipped with enhanced parking brake, manually release enhanced parking brake (WP 0041 00).
5. Station an observer in clear view of both operators to direct towing operation.
6. Shift transmission in dead vehicle to second gear.

TOWED START - CONTINUED**0075 00**

7. Check that FUEL PUMP switch (1) is ON.
8. Turn MASTER switch (2) ON.
9. Press accelerator pedal down about 1/2 inch.
10. Start towing in a straight line or in a wide sweeping turn at about 8 mph. For normal start, refer to WP 0012 00. For cold start, refer to WP 0077 00.
11. If engine fails to start in about 3 to 5 minutes, signal observer, stop vehicles, set brakes, shift transmission to park (P) and troubleshoot (WP 0090 00).
12. When vehicle engine starts, signal observer, and stop vehicles.

CAUTION

If SYSTEM WARNING indicator does not go out in about 20 seconds after engine starts, stop engine and notify unit maintenance. Failure to comply may result in damage to equipment.

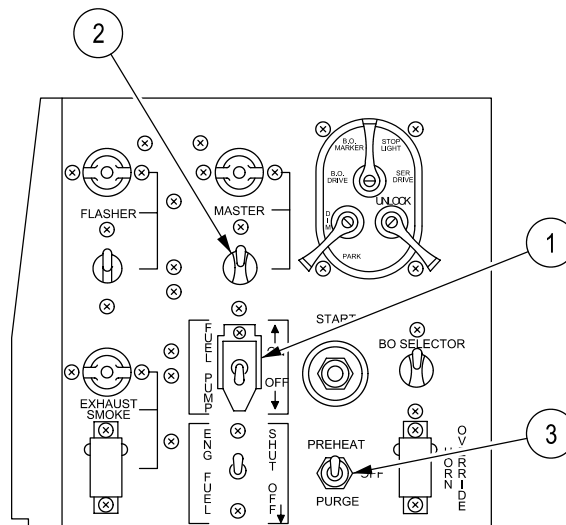

06i005ma

13. Reconnect enhanced parking brake (WP 0041 00), if installed.
14. Set brakes, shift transmissions in both vehicles to park (P).
15. If engine runs roughly during warm-up, hold engine PREHEAT toggle (3) switch to PREHEAT until smooth engine operation returns.
16. After engine is running smoothly, release engine PREHEAT toggle switch (3).
17. Check that engine is operating normally (WP 0013 00).
18. Disconnect tow bar from vehicles and stow (WP 0043 00).

END OF TASK

EXTREME COLD WEATHER OPERATION +32°F TO -25°F (0°C TO -31°C)

0076 00**THIS WORK PACKAGE COVERS:**Extreme Cold Weather +32°F TO -25°F (0°C TO -31°C)

INITIAL SETUP:**Personnel Required**

Three

References

FM 31-70

FM 31-71

FM 90-6

FM 9-207

Extreme cold weather causes oil to thicken, insulation to crack, materials to become brittle and break, and batteries to freeze. Because of these and other problems, the vehicle will be more difficult to operate. Armament used in extreme cold weather operations must be properly lubricated. Vision devices must not be moved suddenly from warm to cold or cold to warm areas. Condensation may cause clouding of lenses and rusting of internal parts. Do not breathe on lenses. Refer to and study the information in FM 31-70, FM 31-71, FM 90-6 and FM 9-207. This information is necessary for effective operation of the vehicle during extreme cold weather.

END OF TASK

STARTING MAIN ENGINE IN COLD WEATHER BELOW +32° TO -25°F (0°C TO -31°C)

0077 00

THIS WORK PACKAGE COVERS:

Starting Vehicle in Cold Weather Below +32°F to -25°F (0° C to -31°C)

INITIAL SETUP:

Personnel Required

Three

References

- WP 0011 00
- WP 0105 00
- WP 0079 00
- WP 0090 00
- WP 0053 00
- WP 0013 00
- WP 0074 00
- TM 21-306



Do not leave the operator's seat while the engine is running. Failure to comply may result in accidental movement of vehicle causing injury or DEATH to personnel.



The use of ether as a starting aid is prohibited. Ether produces extremely high firing pressures which may cause serious engine damage. Failure to comply may result in damage to equipment.

Before moving out, drive slowly for 100 yards (91m) to warm the suspension lubricants. Failure to comply may result in damage to equipment.

NOTE

When the MASTER switch is ON, the warning lights will be lit until the engine is started and oil pressure builds up.

1. Make sure unit maintenance has installed proper grade oil for main engine, transmission and APU.
2. Perform engine prestart procedures (WP 0011 00).
3. Perform all BEFORE operation procedures in PMCS (WP 0105 00, Table 1).

STARTING MAIN ENGINE IN COLD WEATHER BELOW +32° TO -25°F (0°C TO -31°C) - CONTINUED

0077 00

4. Make sure steering wheel (1) is centered and locked.

NOTE

The main engine can be started normally unless battery voltage is too low to power starter motor. The auxiliary power unit can be started to charge batteries (WP 0079 00). If the auxiliary power unit is nonfunctional, the main engine can be slave started (WP 0074 00) or tow started (WP 0075 00). Use APU (WP 0079 00) or a slave vehicle (WP 0074 00) to maintain battery voltage.

5. Start APU (WP 0079 00). After following the recommended APU engine warm-up interval, move the APU GEN switch (2) to ON and charge the main batteries for 30 minutes. The APU charges the batteries as well as adds heat to the engine compartment. Maintain APU operation until after the main engine has started and warmed up.
6. Move FUEL tank toggle switch (3) to FRONT then REAR positions and check the fuel tank levels indicated on the FUEL GAGE (4).
7. Move engine PREHEAT switch (5) to PURGE for 10 seconds and then to OFF position. This will remove air from the fuel lines if the vehicle has been sitting for a long time or maintenance has been performed on fuel system.

CAUTION

Do not hold START button in continuously for longer than 15 seconds. Starter motor will overheat. Failure to comply may result in equipment damage.

NOTE

- Engine PREHEAT switch must be held in PREHEAT position for no longer than 15 seconds prior to cranking engine. As soon as engine starting procedure is initiated (engine is cranking), engage PREHEAT switch until engine has started and throttle response is achieved.
 - All actions in step 8 must be performed simultaneously.
8. Depress accelerator pedal (6) to its full travel. Move spring-loaded ENG FUEL SHUT-OFF toggle switch (7) to OFF position. Move engine PREHEAT switch (5) to PREHEAT position. Depress the engine START button (8) with PREHEAT switch (5) in PREHEAT position. Crank engine for 15 seconds.

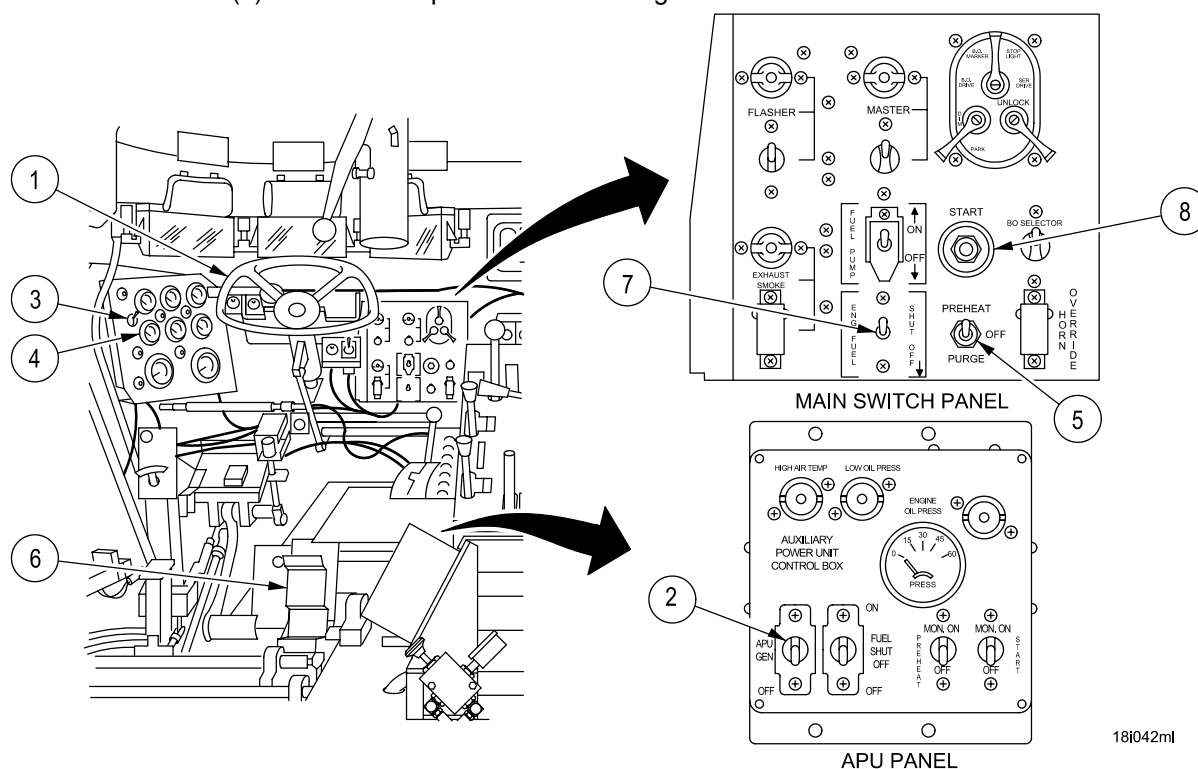

18i042ml

STARTING MAIN ENGINE IN COLD WEATHER BELOW +32° TO -25°F (0°C TO -31°C) - CONTINUED

0077 00

- After 15 seconds of cranking, release spring-loaded ENG FUEL SHUT-OFF toggle switch (7) from OFF position to ON position. Continue to crank until engine starts and engine speed reaches 500 rpm.

NOTE

If engine fails to accelerate between 250 and 500 rpm, remove foot from accelerator pedal.

- As engine accelerates from 500 rpm to idle (850 rpm), continue to depress accelerator pedal (6) to increase engine to 1200 to 1400 rpm.

NOTE

If engine fails to start, perform step 11. If engine starts, go to step 14.

- Release start button (8), turn PREHEAT toggle switch (5) to OFF position, release accelerator pedal (6), and move fuel toggle (7) to OFF position.
- Wait two minutes and repeat steps 8, 9 and 10 until engine runs.
- If engine fails to start after the sixth try, troubleshoot (WP 0090 00).
- After engine achieves throttle response, release engine PREHEAT toggle switch (5), and adjust hand throttle (9) for engine idle speed of 1200-1400 rpm for 15 minutes prior to allowing engine to decrease to low idle (850 rpm) and engaging transmission.
- If engine runs roughly during warm-up, hold engine PREHEAT toggle switch (5) to PREHEAT until smooth engine operation returns.
- After engine is running smoothly, release engine PREHEAT toggle switch (5).

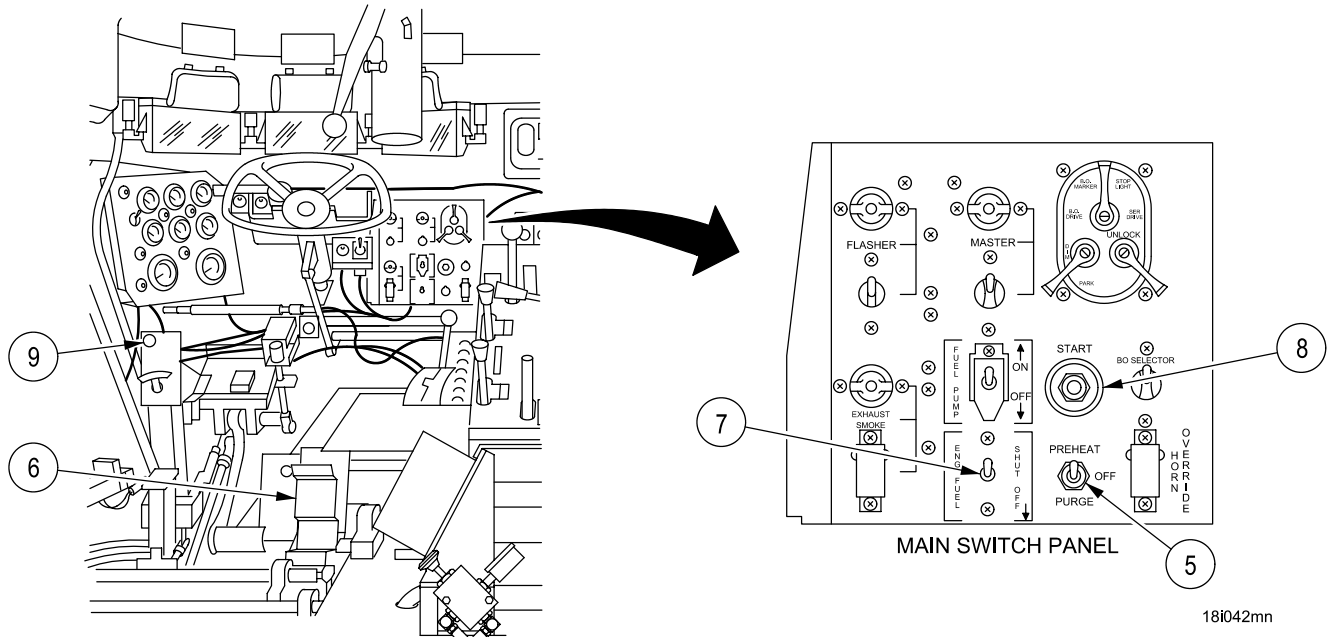

STARTING MAIN ENGINE IN COLD WEATHER BELOW +32° TO -25°F (0°C TO -31°C) - CONTINUED

0077 00**CAUTION**

If the SYSTEM WARNING indicator does not go out 20 seconds after engine starts, stop engine and notify unit maintenance. Failure to comply may result in damage to equipment.

NOTE

During long standstill periods with engine running, hold engine speed at 1,000 to 1,200 rpm to keep it running smoothly.

17. Shut down APU (WP 0053 00).
18. Check engine for normal operation (WP 0013 00).
19. While operating vehicle in cold temperature, check gauge panel frequently in accordance with WP 0013 00 for unusual indications. If any are found, stop vehicle and troubleshoot (WP 0090 00).
20. Refer to FM 21-306 for instructions on driving through snow, ice and unusual terrain.

END OF TASK

PARKING VEHICLE IN EXTREME COLD WEATHER +32°F TO -25°F (0°C TO -31°C)**0078 00****THIS WORK PACKAGE COVERS:**

Parking Vehicle in Extreme Cold Weather +32°F TO -25°F (0°C TO -31°C)

INITIAL SETUP:**Personnel Required**
Three**References**
WP 0105 00**PARKING VEHICLE.****WARNING**

When parking in cold weather, the service brake must be held fully depressed for several seconds after the shift selector is placed in the park (P) position: engaging the parking brake. Release service brake slowly after shifting to park to ensure vehicle does not move. Failure to do so could result in serious injury or DEATH.

1. Park vehicle in a sheltered area, if halted for a short shutdown period. If no shelter is available, have vehicle face wind. For long shutdown periods, park vehicle on high, dry ground or on planks or brush. This prevents the tracks from freezing to the ground. Chock vehicle in place if necessary.
2. When shutting down, place control levers in neutral and transmission shift selection in park (P) so they will not freeze in an engaged position.
3. Clean vehicle of snow, ice, and mud immediately.
4. Perform all AFTER-OPERATION PMCS procedures (WP 0105 00).
5. Cover the vehicle with canvas tarpaulins to protect it from snow. Keep the ends of the cover up off the ground to keep them from freezing to the ground.
6. Protect the batteries from freezing. Have unit maintenance remove and store batteries in a warm area.
7. Refuel the vehicle immediately after operation to reduce condensation in the tanks. Use JP-8 fuel only.

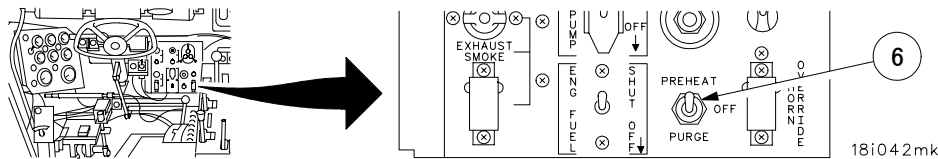
**END OF TASK**

**STARTING AUXILIARY POWER UNIT IN EXTREME COLD WEATHER +32°F
TO -25°F (0°C TO -31°C)**

0079 00**THIS WORK PACKAGE COVERS:**Starting Auxiliary Power Unit in Extreme Cold Weather +32°F TO -25°F (0°C TO -31°C)

INITIAL SETUP:**Personnel Required**

Three

References

WP 0105 00

WP 0053 00

1. Before starting APU in extremely cold weather, refer to WP 0105 00, Table 6 for following:

APU engine crankcase oil grade and level.

APU chaincase oil grade and level.

NOTE

Starting APU in cold weather is same as starting under normal conditions, except PREHEAT switch is held ON for 2 minutes before attempting to start.

2. Start APU (WP 0053 00).

END OF TASK

PREPARATION OF HYDRAULIC SYSTEM FOR OPERATION IN EXTREME COLD WEATHER +32°F TO -25°F (0°C TO -31°C)

0080 00

THIS WORK PACKAGE COVERS:

Preparation of Hydraulic System for Operation in Extreme Cold Weather +32°F TO -25°F (0°C TO -31°C)

INITIAL SETUP:

Personnel Required

Three

References

- WP 0012 00
- WP 0056 00
- WP 0045 00
- WP 0079 00

Before operating hydraulic system in cold weather conditions below 0°F (-18°C), perform the following procedures:

1. Start main engine (WP 0012 00).
2. Close all doors and hatches to crew compartment, except operator's hatch.
3. Start personnel heater (WP 0056 00) and set selector switch to HIGH position for approximately 30 minutes.
4. Open all hinged subfloor plates in crew compartment to allow the heat to circulate under the subfloor to all mechanical components.
5. Start main hydraulic system (WP 0045 00).

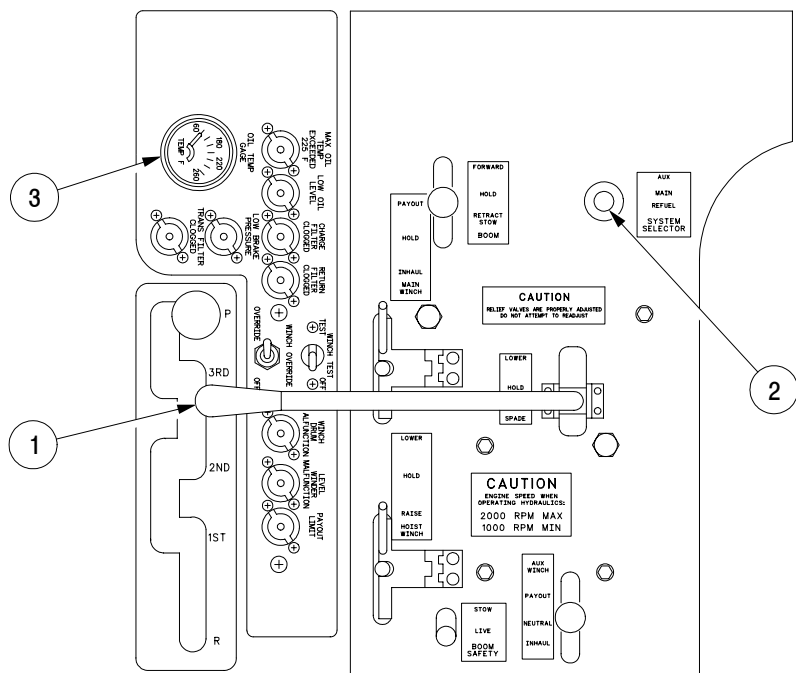

06i011ma

6. Move SPADA operating lever (1) to RAISE position and hold. This causes hydraulic oil to spill over relief valve and warm hydraulic fluid faster.
7. Start APU (WP 0079 00).
8. Move SYSTEM SELECTOR control lever (2) to REFUEL position. This warms auxiliary hydraulic system.
9. Continue to operate system as in step (6) above until hydraulic oil TEMP gauge (3) needle moves off 60°F (15°C), indicating hydraulic oil temperature is at least 60°F (15°C).
10. Operate the Main, Hoist, and Auxiliary winches at a slow speed forward then reverse several times to warm the oil in those units.

END OF TASK

EXTREME HOT WEATHER OPERATION

0081 00**THIS WORK PACKAGE COVERS:**General Information, Operation of Hydraulic System, Vision Devices

INITIAL SETUP:**Personnel Required**

Three

ReferencesFM 21-11

WARNING

Vehicle operation in hot weather can increase the risk of heat stress to crew members. Follow individual preventive medicine measures in FM 21-11 to reduce the risk of heat stress in armored vehicles.

GENERAL INFORMATION

The vehicle may overheat during long, hard towing operations in high gear or when driving at high speed. Check temperature gauges and warning lights often. Stop vehicle to cool off whenever practical. Keep ventilating blower on during operation. Inspect the air cleaners and oil coolers often. Clean off dust, insects, or debris from oil coolers by brushing off screens or flushing with low pressure water. Have unit maintenance add tropical electrolyte to batteries.

OPERATION OF HYDRAULIC SYSTEM

In hot weather and during continuous operation the hydraulic system may generate more heat than can be removed by the hydraulic oil coolers with an engine speed of 1800 rpm. If the hydraulic reservoir temperature gauge reads 160° F or higher, increase the engine speed to 2000 rpm. If the MAX OIL TEMP EXCEEDED indicator comes on (225° F (107°C)), see troubleshooting procedures.

VISION DEVICES

Check the periscopes for fungus growth on the lenses and clean if any is present. If paint is chipped, touch up immediately to prevent rusting.

END OF TASK

UNUSUAL TERRAIN OPERATION

0082 00**THIS WORK PACKAGE COVERS:**Mud, Snow, Ice, Sand and Dust

INITIAL SETUP:**Personnel Required**

Three

ReferencesWP 0116 00

MUD

Use first gear when driving through mud to prevent digging in. Go up and down grades as straight as possible and avoid sharp turns. If vehicle becomes stuck, get towed out. In cold weather operation, park on high, dry ground, on planks or on brush. Chock vehicle if necessary. This will keep the tracks from freezing to the ground. Clean the tracks and wheels of mud before it freezes.

SNOW

You can drive over heavily crusted snow. If vehicle breaks through the crust, shift to first gear and drive slowly to get back on top. Go up and down grades as straight as possible and avoid sharp turns. When snow is soft or fine, drive cautiously.

ICE

Drive carefully and steadily on ice. If vehicle starts to skid, let off the accelerator. Move out slowly.

SAND AND DUST

Be careful not to spin the tracks. If you do, slow down and use the proper gear to move steadily. Do not let the engine labor for too long. It might overheat. When traveling in soft sand, do not make sharp turns in first gear. The tracks will be thrown because of sand building up in the suspension system. Wide turns should be made in second or third gear. Monitor air cleaner restriction indicator gauge, located above air cleaners, for clogging conditions. Clear filters if necessary (WP 0116 00).

END OF TASK

FORDING**0083 00****THIS WORK PACKAGE COVERS:**

Before Fording, Fording, Deep Water Fording, After Fording Operations

INITIAL SETUP:**Personnel Required**

Three

References

WP 0105 00

WP 0005 00

WP 0012 00

WP 0036 00

WP 0125 00

During an operation, it may be necessary to drive the vehicle through water. The depth of the water may be from a few inches to a few feet. Normal fording (without extra equipment) is allowable up to 56 inches (142.2 cm) including bow wave. Perform the following when fording.

BEFORE FORDING

1. Reel in the main winch cable until light pressure is applied between the cable clevis and the trumpet opening. This will reduce the entrance of water.
2. Be sure the engine is fully operational.
3. Make certain the hull drain valves are closed (drain valve lever is up).
4. Make sure all hull-bottom access plates are installed, all bolts in place and tight.

CAUTION

Entering water deeper than 56" (142.2 cm) can allow water to spill into the engine compartment resulting in possible engine component damage.

5. Check water depth. Do not go into water over 56 in. (142.2 cm) deep for normal fording.

FORDING

1. Shift transmission selector to first gear.
2. Increase engine speed to above 950 rpm. Keep engine speed above 950 rpm.
3. Enter water slowly.
4. Keep engine speed above 950 rpm. Drive 3 to 4 mph (5 to 6 kmph) to prevent making a "bow wave".
5. If you completely submerge the vehicle to a point where water enters engine compartment, keep the engine speed up to prevent water from entering engine. Move the vehicle out of water immediately and drain engine compartment by operating hull drain valve lever (push drain valve handle down). If engine stalls while completely submerged, have the vehicle towed out. Send vehicle to unit maintenance as soon as possible for maintenance.
6. If it is necessary to halt the vehicle while engine is submerged, use brakes to stop the vehicle and shift transmission selector to neutral (N). Keep engine speed at 950 to 1,000 rpm. To move again, shift to first gear and move forward slowly at 3 to 4 mph (5 to 6 kmph). Keep engine speed above 950 rpm.

DEEP WATER FORDING

Deep water fording with the M88A2 requires installation of a deep water fording kit. With deep water fording kit installed, the vehicle can ford to a depth of 90 in. (228.6 cm) including "bow wave". Refer to WP 0005 00 for deep water fording kit description. Deep water fording kit must be installed and checked by unit maintenance and crew.

WARNING

Maximum depth of water should be known. Do not exceed a depth of 90 in. (228.6 cm). The highest wave should not reach the opening of main engine air inlets. Exceeding this depth may result in personnel injury or death from drowning.

FORDING - CONTINUED

0083 00**Engine Operation**

1. Start main engine (WP 0012 00).
2. Do not move vehicle until engine is at operating temperature.
3. Drive vehicle in low range while fording.

Fording Procedure and Precautions

1. Have at least one hatch cover opened throughout the fording operations.
2. Enter water slowly to avoid surge of "bow wave".
3. Speed up engine to overcome possibility of stalling when engine is chilled by the water.
4. Do not operate the engine below 950 rpm while fording.
5. Drive at a moderate speed of 3 to 4 mph to avoid forming a "bow wave". Hold this speed by braking if necessary.
6. If it becomes necessary to stop the vehicle while the engine is submerged, place transmission in neutral, locking brakes, and use throttle to maintain engine speed at 950 to 1000 rpm.

NOTE

Should the engine accidentally stop while the vehicle is submerged, restart the engine immediately.

Bilge Pump

1. Open floorplate (WP 0036 00) to observe bilge pump. When water covers bilge pump, turn on bilge pump only when excessive water seepage is apparent.
2. After completion of deep water fording operation or when tactical situation permits, return vehicle to unit maintenance for removal of deep water fording kit and required services.

AFTER FORDING OPERATIONS

1. Open hull drain valves (push drain valve handle down).
2. Run the main engine for a few minutes to help evaporate and blow out any water that may have entered.
3. Check main engine and transmission oil for presence of water (WP 0105 00). If water is present, oil color will be lighter or water will be seen. If oil color is changed or if water is present, notify unit maintenance to drain and refill with correct oil (WP 0105 00).
4. Wipe dry any wet vision devices, and turn them in for reconditioning as soon as possible.
5. Wash and clean vehicle, especially if vehicle was forded in salt water. Do not allow water to enter engine exhaust or air intake vents.
6. Perform after fording maintenance (WP 0125 00).

END OF TASK

NUCLEAR, BIOLOGICAL AND CHEMICAL (NBC) DECONTAMINATION

0084 00**THIS WORK PACKAGE COVERS:**General, Emergency Procedures, Internal Decontamination, External Decontamination

INITIAL SETUP:**Personnel Required**

Three

References

WP 0136 00

FM 3-3

FM 3-4

FM 3-5

TM 3-4230-214-12 & P

GENERAL**NOTE**

Detailed decon procedures can be found in FM 3-3, FM 3-4 and FM-3-5.

The following emergency procedures can be performed until field NBC decontamination facilities are available. M88A2 commander will supervise, assign crew duties, and assist the supporting NBC unit. For location of decontamination equipment mounted on vehicle, see (item 20, WP 0136 00).

EMERGENCY PROCEDURES

If NBC attack is known or suspected, mask at once and continue mission. If inside, do not leave vehicle. If outside, follow decontamination procedures below to avoid taking contamination into the vehicle. Do not unmask until told to do so.

1. Nuclear Decontamination.

Brush fallout from skin, clothing, and equipment with available brushes, rags, and tree branches. Wash skin and have radiation check made as soon as tactical situation permits. (You can find instructions for the check in FM 3-5).

2. Biological Decontamination.

The M88A2 crew has no method to detect or decontaminate biological agents. Remain masked and continue mission until told to unmask.

3. Liquid Chemical Agent Decontamination.

WARNING

Do not use decontamination spray on personnel. It could cause personal injury.

If exposure to liquid agent is known or suspected, clean exposed skin, clothing, and personal gear, in that order. Use the buddy system. Wash exposed skin and thoroughly decontaminate as soon as tactical situation permits.

INTERNAL DECONTAMINATION**WARNING**

NBC contaminated filters must be handled using adequate precautions (FM 3-3) and must be disposed of by trained personnel.

Do not use decontamination spray on personnel. This may cause personal injury.

Use the decontaminating kits as instructed on the kit or in the technical manual. If a chemical agent monitor or other appropriate chemical agent detection device is not available, remain in full MOPP until safe levels are verified. Failure to comply could result in death or injury to personnel.

NOTE

Decontamination procedures take time. Do as much as you can based on the tactical situation.

If decontamination kits are available, use the decontamination kits to decontaminate the following areas.

1. Control handles, levers and switches used to operate crew stations
2. Steering and engine operating controls
3. Radios
4. Weapons
5. Inside doors and hatches

If decontamination kits are not available, use soap and water.

**NUCLEAR, BIOLOGICAL AND CHEMICAL (NBC) DECONTAMINATION -
CONTINUED****0084 00****EXTERNAL DECONTAMINATION****WARNING**

Do not use decontamination spray on personnel. It could cause personal injury.

Use the decontamination kits as instructed on the kit or in the technical manual. If a chemical agent monitor or other appropriate chemical agent detector device is not available, remain in full MOPP until safe levels are verified. Failure to comply could result in death or injury to personnel.

NOTE

One M13 decontamination kit is carried on left outside wall. Refer to TM 3-4230-214-12&P for detailed operation and maintenance of decontamination apparatus. When time permits, decontaminate complete M88A2 per FM 3-5.

If outside of vehicle is contaminated during a chemical or biological attack, open and exit M88A2, remove decontamination kit from left outside wall of the crew compartment and spray the following areas:

- | | |
|-------------------------------|---------------------------------------|
| Mechanic's hatch (1) | Battery access doors (8) |
| Cal .50 machine gun (2) | Fuel filler cap (9) |
| Right side door (3) | Personnel hatch (10) |
| APU door (4) | Left side door (11) |
| Engine deck grille (5) | Commander's hatch (12) |
| Engine deck door (6) | Fire extinguisher T-handle cover (13) |
| Transmission access doors (7) | Driver's hatch (14) |

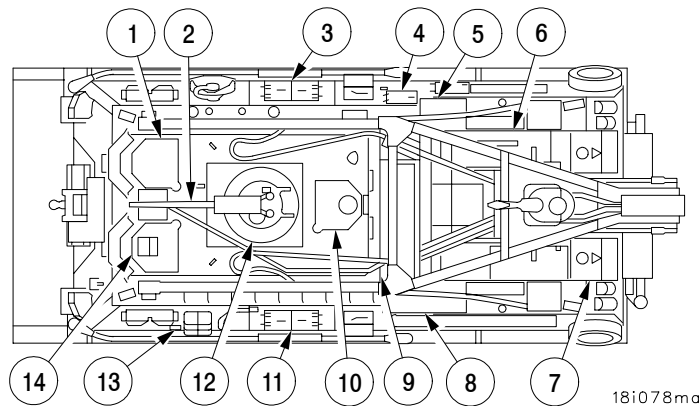
**END OF TASK**

CHAPTER 3

TROUBLESHOOTING

TROUBLESHOOTING INTRODUCTION AND OVERVIEW

0085 00**THIS WORK PACKAGE COVERS:**Troubleshooting Introduction and Overview

INITIAL SETUP:**Personnel Required**

Three

ReferencesWP 0086 00

This section contains information on corrective actions used to return the M88A2 to normal operation. This section lists most malfunctions that may occur along with associated tests, inspections and corrective actions. If a malfunction is not listed, or is not easily corrected, notify unit maintenance.

Always be on the alert for unusual noises. Check out any evidence of failure or malfunction. Crewmembers should report all malfunctions that are seen, felt or heard to the vehicle commander first. Troubleshooting the M88A2 requires crewmembers to perform unscheduled and scheduled maintenance procedures and to monitor system functions at all times. Discovering and correcting a problem when it first appears will usually result in less serious damage to the vehicle and provide safer conditions for crewmembers. When a fault or malfunction is encountered, use the malfunction index for fault identification. The malfunction index (WP 0086 00) will lead the crewmember to applicable system work package troubleshooting procedures, and the corrective action to be taken.

END OF TASK

TROUBLESHOOTING MALFUNCTION/SYMPTOM INDEX

0086 00

THIS WORK PACKAGE COVERS:

Troubleshooting Malfunction/Symptom Index

INITIAL SETUP:

Personnel Required

Three

References

WP 0105 00

NOTE

For corrective actions of malfunctions not listed in this work package, notify Unit Maintenance

Whenever the word lubricate appears refer to WP 0105 00, Table 6.

AUXILIARY POWER UNIT TROUBLESHOOTING **0087 00-1**

Auxiliary Power Unit engine fails to start 0087 00-1

Auxiliary Power Unit starts, but fails to keep running 0087 00-1

BATT- GEN gauge reads in yellow or lower red with APU running and APU GEN switch ON 0087 00-1

BILGE PUMP TROUBLESHOOTING (WHEN INSTALLED) **0088 00-1**

Bilge pump does not pump water 0088 00-1

Bilge pump fails to operate 0088 00-1

BRAKES TROUBLESHOOTING **0089 00**

Brake pump motor runs continuously and brake pressure does not reach 950 psi
old configuration and new configuration) or 1100 to 1300 psi
(new configuration with brake modulation or new configuration with brake modulation and
enhanced parking brake) 0089 00-1

Brakes do not stop vehicle effectively Notify Unit Maintenance

Brakes drag on one or both sides Notify Unit Maintenance

DRIVER'S CONTROLS TROUBLESHOOTING **Notify Unit Maintenance**

Engine does not respond properly to throttle controls Notify Unit Maintenance

Vehicle will not steer or will only steer in one direction Notify Unit Maintenance

ENGINE TROUBLESHOOTING **0090 00-1**

Engine cranks at normal speed but will not start 0090 00-1

Engine fails to crank when START switch is pressed 0090 00-1

Engine cranks slowly and will not start 0090 00-1

Engine has excessive white smoke (or fuel is on grille doors or exhaust grilles) 0090 00-2

Engine has low power and excessive black smoke 0090 00-2

Engine oil temperature is high 0090 00-2

Engine runs rough or misfires and/or knocks 0090 00-2

Engine starts, but fails to keep running 0090 00-2

Engine has low stall RPM and does not develop full power, but exhaust smoke is normal 0090 00-3

Engine overspeeds 0090 00-3

Engine uses excessive oil 0090 00-3

Low (or high) engine oil pressure, oil temperature is normal 0090 00-3

TROUBLESHOOTING MALFUNCTION/SYMPTOM INDEX - CONTINUED **0086 00**

EXHAUST SMOKE GENERATING SYSTEM TROUBLESHOOTING **0091 00-1**

 Vehicle produces poor quality smoke or insufficient quantity of smoke 0091 00-1

 Vehicle fails to make smoke 0091 00-1

 Vehicle produces smoke when exhaust smoke switches are off 0091 00-1

GAS-PARTICULATE FILTER UNIT TROUBLESHOOTING **0092 00-1**

 Lack of air at facepieces 0092 00-1

 Motor does not operate 0092 00-1

GENERATOR SYSTEM TROUBLESHOOTING **0093 00-1**

 Engine BATT-GEN gauge reads in yellow or lower red region with main engine running 0093 00-1

HYDRAULICS SYSTEM TROUBLESHOOTING **0094 00-1**

 Hoist winch fails to operate or develop full power 0094 00-1

 Hoist winch brake fails to hold a load Notify Unit Maintenance

 Hydraulic reservoir overflows Notify Unit Maintenance

 Hydraulic oil constantly overheats 0094 00-1

 Insufficient or no auxiliary oil pressure 0094 00-1

 Insufficient main hydraulics system pressure 0094 00-1

 Main winch fails to operate or fails to develop full power 0094 00-2

 Winch operates on auxiliary hydraulic power, but does not operate on main engine hydraulic power ... 0094 00-2

LIGHTS TROUBLESHOOTING **0095 00-1**

 Any light (except warning indicator and flasher light) flickers, will not go off or will not come on 0095 00-1

 MASTER indicator will not come on when MASTER switch is ON. 0095 00-1

 One or both winch lights fail to operate 0095 00-1

 Panel or vehicle lights do not work 0095 00-1

 Warning FLASHER fails to operate 0095 00-1

 When activating LAMP switch TEST, indicator will not come on 0095 00-1

MONITORING SYSTEM TROUBLESHOOTING **0096 00-1**

 CHARGE FILTER (RETURN FILTER) CLOGGED light stays on 0096 00-1

 Engine OIL TEMPERATURE gauge fails to operate properly Notify Unit Maintenance

 LOW OIL LEVEL indicator comes on 0096 00-1

 TRANSMISSION PRESS gauge indicates less than 17 psi 0096 00-1

 TRANSMISSION TEMP °F gauge indicates 260°F (127°C) or above and SYSTEM WARNING indicator and horn comes on 0096 00-1

 TRANS FILTER CLOGGED indicator stays on Notify Unit Maintenance (When mission allows)

 TURBO DUST DET indicator comes on 0096 00-2

PASSIVE NIGHT VIEWER TROUBLESHOOTING **Refer to TM 11-5855-249-10**

PERSONNEL HEATER UNIT TROUBLESHOOTING **0097 00-1**

 Personnel heater fails to keep burning 0097 00-1

 Personnel heater fails to ignite (heater blower operates properly) 0097 00-1

 Personnel heater fails to operate properly 0097 00-1

 Personnel heater smokes 0097 00-1

TROUBLESHOOTING MALFUNCTION/SYMP TOM INDEX - CONTINUED

0086 00

POWER TAKEOFF ELECTRICAL SYSTEM TROUBLESHOOTING **0099 00-1**
 PTO clutch will not engage 0099 00-1
 PTO CLUTCH ENGAGED indicator does not come on when PTO CLUTCH switch is ON 0099 00-1

RADIO INTERFERENCE SUPPRESSION SYSTEM TROUBLESHOOTING **Notify Unit Maintenance**
 Excessive interference. Main engine and APU not running. Accessories on Notify Unit Maintenance
 Excessive interference with main engine running and vehicle stationary Notify Unit Maintenance

SMOKE GRENADE LAUNCHER SYSTEM TROUBLESHOOTING **0100 00-1**
 Grenade launcher fails to operate properly. Some or all tubes fail to operate.
 All other systems operate properly Notify Unit Maintenance
 System operates but arming light does not come on 0100 00-1

TRACKS AND SUSPENSION TROUBLESHOOTING **0101 00-1**
 Vehicle makes thumping noise during travel 0101 00-1
 Vehicle sags to one side 0101 00-1
 Vehicle pulls to one side when no steering is applied 0101 00-1

TRANSMISSION TROUBLESHOOTING **Notify Unit Maintenance**
 Vehicle steers but will not drive in any range Notify Unit Maintenance
 Vehicle will not drive in low range Notify Unit Maintenance
 Vehicle will not drive in intermediate range Notify Unit Maintenance
 Vehicle will not drive in high range Notify Unit Maintenance
 Vehicle will drive forward but not reverse Notify Unit Maintenance
 Vehicle creeps in neutral Notify Unit Maintenance

VENTILATING BLOWER TROUBLESHOOTING **0102 00-1**
 Ventilating blower fails to operate properly. All other system operate properly. 0102 00-1

WARNING SYSTEM TROUBLESHOOTING **0103 00-1**
 SYSTEM WARNING indicator will not come on when activating WINCH TEST switch 0103 00-1
 LOW BRAKE PRESSURE warning light comes on and warning horn sounds Notify Unit Maintenance

WINCH ELECTRICAL SYSTEM TROUBLESHOOTING **0104 00-1**
 LEVEL WINDER MALFUNCTION indicator comes on 0104 00-1
 PAYOUT LIMIT indicator comes on 0104 00-2
 WINCH DRUM MALFUNCTION indicator comes on 0104 00-3
 WINCH DRUM MALFUNCTION indicator lights, winch is operating properly 0104 00-4
 WINCH PAYOUT LIMIT indicator lights, winch is operating properly 0104 00-4

AUXILIARY POWER UNIT TROUBLESHOOTING

0087 00

THIS WORK PACKAGE COVERS:

Auxiliary Power Unit engine fails to start	0087 00-1
Auxiliary Power Unit starts, but fails to keep running	0087 00-1
BATT-GEN gauge reads in yellow or lower red with APU running and APU GEN switch ON	0087 00-1

INITIAL SETUP:

Personnel Required
Three

References
WP 0074 00
WP 0117 00
WP 0105 00
WP 0033 00

AUXILIARY POWER UNIT ENGINE FAILS TO START

- Step 1. If APU will not crank, check BATT-GEN gauge for low battery charge.
Slave start the vehicle and charge batteries (WP 0074 00).
- Step 2. Check and ensure APU GEN switch is in the OFF position.
Place APU GEN switch in the OFF position.
- Step 3. Check air intake for restrictions.
Remove any restrictions and clean air filter (WP 0117 00).
- Step 4. Use fuel gauge to check rear fuel tank fuel level.
Refuel vehicle.
- Step 5. If problem still exists, notify unit maintenance (AUXILIARY POWER UNIT ENGINE FAILS TO START).

AUXILIARY POWER UNIT STARTS, BUT FAILS TO KEEP RUNNING

- Step 1. Check for water in the fuel filters.
Drain fuel filters for condensation (WP 0105 00).
- Step 2. Check air intake for restrictions.
Remove any restrictions and clear air filter (WP 0117 00).
- Step 3. If problem still exists, notify unit maintenance (AUXILIARY POWER UNIT FAILS TO KEEP RUNNING).

BATT-GEN GAUGE READS IN YELLOW OR LOWER RED WITH APU RUNNING AND APU GEN SWITCH ON

- Step 1. Remove air intake grille above voltage regulator (WP 0033 00).
- Step 2. Press reset button on voltage regulator.
- Step 3. If problem still exists, notify maintenance (BATT/GEN GAUGE READS IN YELLOW OR LOWER RED WITH APU RUNNING AND APU GEN SWITCH ON).

END OF TASK

BILGE PUMP TROUBLESHOOTING (WHEN INSTALLED)

0088 00

THIS WORK PACKAGE COVERS:

Bilge pump does not pump water	0088 00-1
Bilge pump fails to operate	0088 00-1

INITIAL SETUP:

Personnel Required

Three

BILGE PUMP DOES NOT PUMP WATER

Step 1. Check for a clogged bilge pump inlet.

Remove obstruction from pump inlet. If failure is due to clogged pump screen, notify unit maintenance.

Step 2. Check for a clogged bilge pump vent.

Remove obstruction from pump vent.

Step 3. If problem still exists, notify unit maintenance (BILGE PUMP FAILS TO OPERATE).

BILGE PUMP FAILS TO OPERATE

Step 1. Reset bilge pump circuit breaker switch on Accessory/PTO panel.

Step 2. If problem still exists, notify unit maintenance (BILGE PUMP FAILS TO OPERATE).

END OF TASK

BRAKES TROUBLESHOOTING

0089 00

THIS WORK PACKAGE COVERS:

Brake pump motor runs continuously and brake pressure does not reach 950 psi old configuration and new configuration or 1100 to 1300 psi (new configuration with brake modulation or new configuration with brake modulation and enhanced parking brake) 0089 00

INITIAL SETUP:

Personnel Required

Three

References

WP 0105 00

WP 0122 00

BRAKES

BRAKE PUMP MOTOR RUNS CONTINUOUSLY AND BRAKE PRESSURE DOES NOT REACH 950 PSI (OLD CONFIGURATION AND NEW CONFIGURATION) OR 1100 TO 1300 PSI (NEW CONFIGURATION WITH BRAKE MODULATION OR NEW CONFIGURATION WITH BRAKE MODULATION AND ENHANCED PARKING BRAKE)

Step 1. Check hydraulic reservoir fluid level (WP 0105 00).

Fill hydraulic reservoir (WP 0105 00).

Step 2. Check for air trapped in brake hydraulic lines.

Bleed brakes (WP 0122 00).

Step 3. If problem still exists, notify unit maintenance (BRAKE PUMP MOTOR RUNS CONTINUOUSLY AND BRAKE PRESSURE DOES NOT REACH 950 PSI (old configuration) or 1100 to 1300 psi (new configuration with brake modulation or new configuration with brake modulation and enhanced parking brake)).

END OF TASK

ENGINE TROUBLESHOOTING

0090 00

THIS WORK PACKAGE COVERS:

Engine cranks at normal speed but will not start	0090 00-1
Engine fails to crank when START switch is pressed	0090 00-1
Engine cranks slowly and will not start	0090 00-1
Engine has excessive white smoke (or fuel is on grille doors on exhaust grilles)	0090 00-2
Engine has low power and excessive black smoke	0090 00-2
Engine oil temperature is high	0090 00-2
Engine runs rough or misfires and/or knocks	0090 00-2
Engine starts, but fails to keep running	0090 00-2
Engine has low stall RPM and does not develop full power, but exhaust smoke is normal	0090 00-3
Engine overspeeds	0090 00-3
Engine uses excessive oil	0090 00-3
Low (or high) engine oil pressure, oil temperature is normal	0090 00-3

INITIAL SETUP:

Personnel Required

Three

References

- WP 0053 00
- WP 0116 00
- WP 0105 00
- WP 0108 00
- WP 0109 00

ENGINE CRANKS AT NORMAL SPEED BUT WILL NOT START

- Step 1. Check fuel gauge to ensure enough fuel is present.
 - Refuel vehicle.
- Step 2. Check manual FUEL shutoff handle.
 - Push in manual FUEL shutoff handle.
- Step 3. Check FUEL PUMP switch.
 - Turn on FUEL PUMP switch.
- Step 4. Check fire extinguisher pull handle shield.
 - Secure shield with push release pin.
- Step 5. Check for air trapped in the fuel lines.
 - Operate ENGINE PREHEAT switch for 10 seconds.
- Step 6. If problem still exists, notify unit maintenance (ENGINE CRANKS AT NORMAL SPEED BUT WILL NOT START).

ENGINE FAILS TO CRANK WHEN START SWITCH IS PRESSED

- Step 1. Check BATT-GEN gauge for low battery charge.
 - Start APU and charge batteries (WP 0053 00).
- Step 2. If problem still exists, notify unit maintenance (ENGINE FAILS TO CRANK WHEN START SWITCH IS PRESSED).

ENGINE CRANKS SLOWLY AND WILL NOT START

- Step 1. Check BATT-GEN gauge for low battery charge.
- Step 2. Start APU and charge batteries (WP 0053 00).
- Step 3. If problem still exists, notify unit maintenance (ENGINE CRANKS SLOWLY AND WILL NOT START).

ENGINE TROUBLESHOOTING - CONTINUED

0090 00**ENGINE HAS EXCESSIVE WHITE SMOKE (OR FUEL IS ON GRILLE DOORS ON EXHAUST GRILLES)**

- Step 1. Make sure both operator's and commander's exhaust smoke generator switches are OFF.
- Step 2. Make sure exhaust smoke generator manual fuel shutoff valve is closed.
- Step 3. If problem still exists, notify unit maintenance (ENGINE HAS EXCESSIVE WHITE SMOKE).

ENGINE HAS LOW POWER AND EXCESSIVE BLACK SMOKE

- Step 1. Check air cleaner restriction gauge.
Clean air filters (WP 0116 00).
- Step 2. If problem still exists, notify unit maintenance (ENGINE HAS LOW POWER AND EXCESSIVE BLACK SMOKE).

ENGINE OIL TEMPERATURE IS HIGH

- Step 1. Check main engine oil level.
Fill as specified in (WP 0105 00).
- Step 2. Check oil coolers for restrictions.
Clean oil cooler screens with low pressure water.
- Step 3. Check track tension.
Adjust track tension (WP 0108 00 or WP 0109 00).
- Step 4. If problem still exists, notify unit maintenance (ENGINE OIL TEMPERATURE IS HIGH).

ENGINE RUNS ROUGH OR MISFIRES AND/OR KNOCKS

- Step 1. Check air cleaner restriction gauge.
Clean air filters (WP 0116 00).
- Step 2. Check for fuel leaks.
Shut down main engine and notify unit maintenance.
- Step 3. Engine operating at below normal temperature (one or more cylinders not firing).
Run engine at a higher rpm (1,000 - 1,800) for 3 to 5 minutes.
- Step 4. If problem still exists, notify unit maintenance (ENGINE RUNS ROUGH OR MISFIRES AND/OR KNOCKS).

ENGINE STARTS, BUT FAILS TO KEEP RUNNING

- Step 1. Check fuel level.
Refuel vehicle.
- Step 2. Ensure that air is not trapped in fuel lines.
Operate engine PREHEAT switch for 10 seconds to remove air from fuel lines.
- Step 3. Check air cleaners for restrictions.
Clean air filters and air inlets (WP 0116 00).
- Step 4. If problem still exists, notify unit maintenance (ENGINE STARTS BUT FAILS TO KEEP RUNNING).

ENGINE TROUBLESHOOTING - CONTINUED

0090 00**ENGINE HAS LOW STALL RPM AND DOES NOT DEVELOP FULL POWER, BUT EXHAUST SMOKE IS NORMAL**

Step 1. Check fire extinguisher shutoff switch to ensure quick-release pin is engaged.

Step 2. Check FORWARD TANK FUEL CONTROL VALVE to ensure it is OPEN.

Open FORWARD TANK FUEL CONTROL VALVE.

NOTE

Operation for long periods in recovery operation with vehicle in fixed position on incline will lower front fuel tank supply below pump inlet.

Step 3. If problem still exists, notify unit maintenance (ENGINE HAS LOW STALL RPM AND DOES NOT DEVELOP FULL POWER, BUT EXHAUST SMOKE IS NORMAL).

ENGINE OVERSPEEDS

Step 1. Check and ensure hand throttle is in.

Push in hand throttle.

Step 2. If problem still exists, notify unit maintenance (ENGINE OVERSPEEDS).

ENGINE USES EXCESSIVE OIL

Step 1. Check for oil draining out of hull drains from oil leak in engine compartment.

Notify unit maintenance.

Step 2. Check engine oil level for over fill.

Notify unit maintenance.

Step 3. Check air filter elements for holes and tears (WP 0116 00).

Notify unit maintenance.

Step 4. If problem still exists, notify unit maintenance (ENGINE USES EXCESSIVE OIL).

LOW (OR HIGH) ENGINE OIL PRESSURE, OIL TEMPERATURE IS NORMAL

Step 1. Check engine oil level.

Fill as specified in WP 0105 00.

Step 2. If problem still exists, notify unit maintenance (LOW (OR HIGH) ENGINE OIL PRESSURE, OIL TEMPERATURE IS NORMAL).

END OF TASK

EXHAUST SMOKE GENERATING SYSTEM TROUBLESHOOTING

0091 00

THIS WORK PACKAGE COVERS:

Vehicle produces poor quality smoke or insufficient quantity of smoke	0091 00-1
Vehicle fails to make smoke	0091 00-1
Vehicle produces smoke when exhaust smoke switches are off	0091 00-1

INITIAL SETUP:

Personnel Required

Three

VEHICLE PRODUCES POOR QUALITY SMOKE OR INSUFFICIENT QUANTITY OF SMOKE

- Step 1. Check for fuel running out of hull drains or mixed with cooling air.
 Shut down main engine and notify unit maintenance.
- Step 2. If problem still exists, notify unit maintenance (VEHICLE PRODUCES POOR QUALITY SMOKE OR INSUFFICIENT QUANTITY OF SMOKE).

VEHICLE FAILS TO MAKE SMOKE

- Step 1. Check fuel type.
 Exhaust smoke generating system will not produce smoke with JP-8 fuel.
- Step 2. Check fuel shutoff valve.
 Open fuel shutoff valve.
- Step 3. Check for fuel running out of hull drains or mixing with cooling air.
 Shut down main engine and notify unit maintenance.
- Step 4. If problem still exists, notify unit maintenance (VEHICLE FAILS TO MAKE SMOKE).

VEHICLE PRODUCES SMOKE WHEN EXHAUST SMOKE SWITCHES ARE OFF

- Step 1. Make sure both operator's and commander's exhaust smoke generator switches are OFF.
- Step 2. Make sure exhaust smoke generator manual fuel shutoff valve is closed.
- Step 3. If problem still exists, notify unit maintenance (VEHICLE PRODUCES SMOKE WHEN EXHAUST SMOKE SWITCHES ARE OFF).

END OF TASK

GAS-PARTICULATE FILTER UNIT TROUBLESHOOTING

0092 00

THIS WORK PACKAGE COVERS:

Lack of air at facepieces	0092 00-1
Motor does not operate	0092 00-1

INITIAL SETUP:

Personnel Required

Three

LACK OF AIR AT FACEPIECES

Step 1. Check for kinked, pinched, clogged or loose hose connections.

 Straighten kinked or pinched hoses, unclog hoses and tighten loose connections.

Step 2. If no heated air flows, turn M3 HEATER switch ON and adjust heater.

Step 3. If problem still exists, notify unit maintenance (LACK OF AIR AT FACEPIECES).

MOTOR DOES NOT OPERATE

Step 1. Reset ON/OFF circuit breaker switch on control unit.

Step 2. If problem still exists, notify unit maintenance (MOTOR DOES NOT OPERATE).

END OF TASK

GENERATOR SYSTEM TROUBLESHOOTING

0093 00

THIS WORK PACKAGE COVERS:

Engine BATT-GEN gauge reads in yellow or lower red region with main engine running 0093 00-1

INITIAL SETUP:

Personnel Required

Three

References

WP 0034 00

ENGINE BATT-GEN GAUGE READS IN YELLOW OR LOWER RED REGION WITH MAIN ENGINE RUNNING

- Step 1. Remove engine deck left side grille above voltage regulator (WP 0034 00).
- Step 2. Remove splash shield above voltage regulator.
- Step 3. Reset main engine voltage regulator circuit breaker (located on top of voltage regulator) to ON position.
- Step 4. If problem still exists, notify unit maintenance (ENGINE BATT-GEN GAUGE READS IN YELLOW OR LOWER RED REGION WITH MAIN ENGINE RUNNING).

END OF TASK

HYDRAULICS SYSTEM TROUBLESHOOTING

0094 00

THIS WORK PACKAGE COVERS:

Hoist winch fails to operate or develop full power	0094 00-1
Hydraulic oil constantly overheats	0094 00-1
Insufficient or no auxiliary oil pressure	0094 00-1
Insufficient main hydraulics system pressure	0094 00-1
Main winch fails to operate or fails to develop full power	0094 00-2
Winch operates on auxiliary hydraulic power, but does not operate on main engine hydraulic power ..	0094 00-2

INITIAL SETUP:

Personnel Required

Three

References

- WP 0045 00
 - WP 0105 00
 - WP 0036 00
-

HOIST WINCH FAILS TO OPERATE OR DEVELOP FULL POWER

Step 1. Check oil level in hydraulic reservoir.

Fill as specified in WP 0105 00.

Step 2. Attempt to operate with PTO clutch manually engaged (WP 0045 00).

Step 3. If problem still exists, notify unit maintenance (HOIST WINCH FAILS TO OPERATE OR DEVELOP FULL POWER).

HYDRAULIC OIL CONSTANTLY OVERHEATS

Step 1. Check OIL TEMP GAGE for high temperature indication.

If gauge indicates high temperature (above 225°F (107°C)), ensure PTO CLUTCH switch is ON. Stop any operations using the hydraulics system. Run the engine at 2000 RPM to circulate oil through the hydraulic oil cooler until oil cools and indicator goes off.

Step 2. If problem still exists, notify unit maintenance (HYDRAULIC OIL CONSTANTLY OVERHEATS).

INSUFFICIENT OR NO AUXILIARY OIL PRESSURE

Step 1. Check and ensure system selector lever is in auxiliary position.

Place system selector lever in auxiliary position.

Step 2. Check oil level in hydraulic reservoir (WP 0105 00).

Fill as specified in WP 0105 00.

Step 3. If problem still exists, notify unit maintenance (INSUFFICIENT OR NO AUXILIARY OIL PRESSURE).

INSUFFICIENT MAIN HYDRAULICS SYSTEM PRESSURE

Step 1. Remove subfloor plates above hydraulic lines and components (WP 0036 00).

Step 2. Inspect lines and components for leaks.

Step 3. Tighten fittings and connections.

Step 4. Attempt to operate with PTO clutch manually engaged (WP 0045 00).

Step 5. If problem still exists, notify unit maintenance (INSUFFICIENT MAIN HYDRAULICS SYSTEM PRESSURE).

HYDRAULICS SYSTEM TROUBLESHOOTING - CONTINUED

0094 00

MAIN WINCH FAILS TO OPERATE OR FAILS TO DEVELOP FULL POWER

Step 1. Check oil level in hydraulic reservoir (WP 0105 00).

Fill as specified in WP 0105 00.

Step 2. Attempt to operate with PTO clutch manually engaged (WP 0045 00).

Step 3. If problem still exists, notify unit maintenance (MAIN WINCH FAILS TO OPERATE OR FAILS TO DEVELOP FULL POWER).

WINCH OPERATES ON AUXILIARY HYDRAULIC POWER, BUT DOES NOT OPERATE ON MAIN ENGINE HYDRAULIC POWER

Step 1. Check that PTO CLUTCH switch is ON.

Place PTO CLUTCH switch in ON position.

Step 2. Attempt to operate with PTO clutch manually engaged (WP 0045 00).

Step 3. If problem still exists, notify unit maintenance (PTO CLUTCH DOES NOT ENGAGE, INDICATOR IS NOT LIT AND GOVERNOR DOES NOT OPERATE PROPERLY).

END OF TASK

LIGHTS TROUBLESHOOTING

0095 00

THIS WORK PACKAGE COVERS:

Any light (except warning indicator and flasher light) flickers, will not go off or will not come on	0095 00-1
MASTER indicator will not come on when MASTER switch is ON	0095 00-1
One or both winch lights fail to operate	0095 00-1
Panel or vehicle lights do not work	0095 00-1
Warning FLASHER fails to operate	0095 00-1
When activating LAMP switch TEST, indicator will not come on	0095 00-1

INITIAL SETUP:

Personnel Required
Three

ANY LIGHT (EXCEPT WARNING INDICATOR AND FLASHER LIGHT) FLICKERS, WILL NOT GO OFF OR WILL NOT COME ON

- Step 1. Check lamp.
Tighten or replace lamp as required.
- Step 2. If problem still exists, notify unit maintenance (LIGHTS).

MASTER INDICATOR WILL NOT COME ON WHEN MASTER SWITCH IS ON

- Step 1. Check lamp.
Replace lamp.
- Step 2. If problem still exists, notify unit maintenance (LIGHTS).

ONE OR BOTH WINCH LIGHTS FAIL TO OPERATE

- Step 1. Reset winch light circuit breaker switch on PTO/Accessory panel.
- Step 2. If problem still exists, notify unit maintenance (ONE OR BOTH WINCH LIGHTS FAIL TO OPERATE).

PANEL OR VEHICLE LIGHTS DO NOT WORK

- Step 1. Check MASTER switch.
Turn MASTER switch ON.
- Step 2. If problem still exists, notify unit maintenance (LIGHTS).

WARNING FLASHER FAILS TO OPERATE

- Step 1. Check lamp.
Replace lamp.
- Step 2. If problem still exists, notify unit maintenance (WARNING FLASHER LIGHT FAILS TO OPERATE).

WHEN ACTIVATING LAMP SWITCH TEST, INDICATOR WILL NOT COME ON

- Step 1. Check lamp.
Replace lamp.
- Step 2. If problem still exists, notify unit maintenance. (WHEN ACTIVATING LAMP SWITCH TEST, INDICATOR WILL NOT COME ON).

END OF TASK

MONITORING SYSTEM TROUBLESHOOTING

0096 00

THIS WORK PACKAGE COVERS:

CHARGE FILTER (RETURN FILTER) CLOGGED light stays on	0096 00-1
LOW OIL LEVEL indicator comes on	0096 00-1
TRANSMISSION PRESS gauge indicates less than 17 psi	0096 00-1
TRANSMISSION TEMP °F gauge indicates 260° F (127° C) or above and SYSTEM WARNING indicator and horn come on	0096 00-1
TURBO DUST DET indicator comes on	0096 00-2

INITIAL SETUP:

Personnel Required

Three

References

- WP 0036 00
- WP 0105 00
- WP 0040 00
- WP 0116 00
- WP 0120 00

CHARGE FILTER (RETURN FILTER) CLOGGED LIGHT STAYS ON

- Step 1. Remove subfloor plate above filter manifold (WP 0036 00).
- Step 2. Push reset button on charge filter.
- Step 3. If problem still exists, notify unit maintenance (CHARGE FILTER (RETURN FILTER) CLOGGED LIGHT STAYS ON).

LOW OIL LEVEL INDICATOR COMES ON



Turn PTO CLUTCH switch OFF immediately to prevent serious damage to hydraulic pump.

- Step 1. Check compartment for leaks.
- Step 2. Check reservoir and fill as specified in WP 0105 00.
- Step 3. If problem still exists, notify unit maintenance (HYDRAULIC LOW OIL LEVEL WARNING LIGHT STAYS ON. RESERVOIR IS FULL).

TRANSMISSION PRESS GAUGE INDICATES LESS THAN 17 PSI

- Step 1. Check transmission oil level (WP 0105 00).
Fill as specified in WP 0105 00.
- Step 2. If problem still exists, notify unit maintenance (TRANSMISSION OIL PRESSURE GAUGE FAILS TO OPERATE).

TRANSMISSION TEMP °F GAUGE INDICATES 260°F (127°C) OR ABOVE AND SYSTEM WARNING INDICATOR AND HORN COME ON

- Step 1. Check oil cooler screens for restriction of air flow.
Clean oil cooler screens with low pressure water.
- Step 2. Check transmission oil level (WP 0105 00).
Fill as specified in WP 0105 00.
- Step 3. Problem occurs during towing operation or when on rough ground.
Follow procedures listed under TOWING OPERATIONS (WP 0040 00).
- Step 4. If problem still exists, notify unit maintenance (TRANSMISSION OIL TEMPERATURE HIGH).

MONITORING SYSTEM TROUBLESHOOTING - CONTINUED

0096 00**TURBO DUST DET INDICATOR COMES ON**

Step 1. Check air cleaner housing for excessive contamination, and air cleaner restriction gauge indicators.

Clean air filters and housings (WP 0116 00).

Step 2. Turbo dust detector filter clogged light on.

- a. Check turbo dust detector switch on top of both turbochargers to determine which filter is clogged.

Service turbo dust detector (WP 0120 00).

- b. Check air tubes and joints for leaks, and check clamps for tightness.
- c. Continue with mission and monitor indicator.
- d. On completion of mission, if problem still exists, notify unit maintenance [DUST DETECTOR SYSTEM OPERATES IMPROPERLY (POWER PLANT WARNING LAMP AND DUST DETECTOR WARNING LAMP ON AND PRESSURE SWITCH PLUNGERS ARE VISIBLE)].

END OF TASK

PERSONNEL HEATER UNIT TROUBLESHOOTING

0097 00

THIS WORK PACKAGE COVERS:

Personnel heater fails to keep burning	0097 00-1
Personnel heater fails to ignite (heater blower operates properly)	0097 00-1
Personnel heater fails to operate properly	0097 00-1
Personnel heater smokes	0097 00-1

INITIAL SETUP:

Personnel Required

Three

PERSONNEL HEATER FAILS TO KEEP BURNING

Step 1. Check fuel level.

Refuel vehicle.

Step 2. Check for loose cable connection.

Tighten loose cable connection.

Step 3. If problem still exists, notify unit maintenance (PERSONNEL HEATER FAILS TO KEEP BURNING).

PERSONNEL HEATER FAILS TO IGNITE (HEATER BLOWER OPERATES PROPERLY)

Step 1. Check fuel level.

Refuel vehicle.

Step 2. If problem still exists, notify unit maintenance (PERSONNEL HEATER FAILS TO IGNITE (HEATER BLOWER OPERATES PROPERLY)).

PERSONNEL HEATER FAILS TO OPERATE PROPERLY

Step 1. Check for loose cable connection.

Tighten loose cable connection.

Step 2. If problem still exists, notify unit maintenance (PERSONNEL HEATER FAILS TO OPERATE PROPERLY).

PERSONNEL HEATER SMOKES

Step 1. Check exhaust for restrictions.

Remove restriction from exhaust.

Step 2. If problem still exists, notify unit maintenance (PERSONNEL HEATER SMOKES).

END OF TASK

A20 PERSONNEL HEATER UNIT TROUBLESHOOTING

0098 00

THIS WORK PACKAGE COVERS:

NOTE

The operator can troubleshoot the codes listed below when displayed in the diagnostic display window. If any other codes are displayed, notify UNIT maintenance.

No personnel heater operation, no fault lamp operation, no diagnostic code display	0098 00-1
C3, Vent fan fault	0098 00-1
E1, Low voltage	0098 00-1
E3, Low burner air flow	0098 00-2
F1, Ignition overtime	0098 00-2
F2, Burner flameout	0098 00-2
F3, Heat limit	0098 00-2
F4, Vent air overheat	0098 00-2
F6, Inlet overheat, Vehicle ambient temperature is above 131°F (56°C)	0098 00-2
F7, Exhaust overheat	0098 00-2

INITIAL SETUP:

Personnel Required

Three

NO PERSONNEL HEATER OPERATION, NO FAULT LAMP OPERATION, NO DIAGNOSTIC CODE DISPLAY

Step 1. Check MS power connection.

Tighten connector.

Step 2. Restart heater.

Step 3. If problem still exists, notify UNIT maintenance (NO PERSONNEL HEATER OPERATION, NO FAULT LAMP OPERATION, NO DIAGNOSTIC CODE DISPLAY).

C3, VENT FAN FAULT

Step 1. Check for frost or obstruction in vent fan.

Remove frost or obstruction.

Step 2. Start personnel heater.

Step 3. If problem still exists, notify UNIT maintenance (C3, VENT FAN FAULT).

E1, LOW VOLTAGE

Step 1. Check for loose cable connection.

Tighten loose cable connection.

Step 2. If problem still exists, notify UNIT maintenance (E1, LOW VOLTAGE).

A20 PERSONNEL HEATER UNIT TROUBLESHOOTING - CONTINUED

0098 00**E3, LOW BURNER AIR FLOW**

Step 1. Check exhaust for restrictions.

Remove restriction from exhaust.

Step 2. Check for combustion air restriction.

Remove combustion air restriction.

Step 3. Restart personnel heater. If problem still exists, notify UNIT maintenance (E3, LOW BURNER AIR FLOW).

F1, IGNITION OVERTIME

Step 1. Check fuel supply.

Add fuel if necessary.

Step 2. Restart heater.

Step 3. If problem still exists, notify UNIT maintenance (F1, IGNITION OVERTIME).

F2, BURNER FLAMEOUT

Step 1. Check fuel supply.

Add fuel if necessary.

Step 2. Restart heater.

Step 3. If problem still exists, notify UNIT maintenance (F2, BURNER FLAMEOUT).

F3, HEAT LIMIT

Step 1. Check for obstructed heater outlet.

Remove outlet obstruction.

Step 2. Restart heater.

Step 3. If problem still exists, notify UNIT maintenance (F3, HEAT LIMIT).

F4, VENT AIR OVERHEAT

Step 1. Check for obstructed heater output ventilation.

Remove obstruction.

Step 2. Restart heater.

Step 3. If problem still exists, notify UNIT maintenance (F4, VENT AIR OVERHEAT).

F6, INLET OVERHEAT, VEHICLE AMBIENT TEMPERATURE IS ABOVE 131°F (55°C)

Step 1. Wait until the temperature is below 131°F. F6 display code will be cancelled when vehicle temperature is below 104°F.

Step 2. Manually purge the heater three (3) times.

Step 3. Restart heater.

Step 4. If problem still exists, notify UNIT maintenance (F6, INLET OVERHEAT, VEHICLE AMBIENT TEMPERATURE IS ABOVE 131°F (55°C)).

F7, EXHAUST OVERHEAT

Step 1. Check for obstruction in air inlet or exhaust.

Step 2. Remove obstruction.

Step 3. Restart heater.

Step 4. If problem still exists, notify UNIT maintenance (F7, EXHAUST OVERHEAT).

POWER TAKEOFF ELECTRICAL SYSTEM TROUBLESHOOTING

0099 00

THIS WORK PACKAGE COVERS:

- PTO clutch will not engage 0099 00-1
PTO CLUTCH ENGAGED indicator does not come on when PTO CLUTCH switch is ON 0099 00-1
-

INITIAL SETUP:

Personnel Required

Three

References

- WP 0045 00
WP 0036 00
-

PTO CLUTCH WILL NOT ENGAGE

- Step 1. Reset PTO clutch circuit breaker switch on PTO/Accessory panel.
- Step 2. Remove subfloor plate over PTO clutch and manually engage clutch (WP 0036 00).
- Step 3. If problem still exists, notify unit maintenance (PTO CLUTCH DOES NOT ENGAGE, INDICATOR IS NOT LIT AND GOVERNOR DOES NOT OPERATE PROPERLY).

PTO CLUTCH ENGAGED INDICATOR DOES NOT COME ON WHEN PTO CLUTCH SWITCH IS ON

- Step 1. Check lamp.
 - Replace lamp.
- Step 2. Check and ensure PTO clutch is engaged.
 - For emergency use, activate manual clutch lock (WP 0045 00).
- Step 3. If problem still exists, notify unit maintenance (PTO CLUTCH DOES NOT ENGAGE, INDICATOR IS NOT LIT AND GOVERNOR DOES NOT OPERATE PROPERLY).

END OF TASK

SMOKE GRENADE LAUNCHER SYSTEM TROUBLESHOOTING

0100 00

THIS WORK PACKAGE COVERS:

System operates but arming light does not come on 0100 00-1

INITIAL SETUP:

Personnel Required

Three

SYSTEM OPERATES BUT ARMING LIGHT DOES NOT COME ON

Step 1. Check lamp.

Replace lamp.

Step 2. If problem still exists, notify unit maintenance (GRENADE LAUNCHER FAILS TO OPERATE PROPERLY. SOME OR ALL TUBES FAIL TO OPERATE. ALL OTHER SYSTEMS OPERATE PROPERLY).

END OF TASK

TRACKS AND SUSPENSION TROUBLESHOOTING

0101 00

THIS WORK PACKAGE COVERS:

Vehicle makes thumping noise during travel	0101 00-1
Vehicle sags to one side	0101 00-1
Vehicle pulls to one side when no steering is applied	0101 00-1

INITIAL SETUP:

Personnel Required
Three

References
WP 0105 00
WP 0113 00
WP 0108 00
WP 0109 00

VEHICLE MAKES THUMPING NOISE DURING TRAVEL

- Step 1. Check for dead track shoes (WP 0105 00).
 Replace dead track shoe (WP 0113 00).
- Step 2. Check track and suspension system for debris stuck in components.
 Remove debris.
- Step 3. Check track tension.
 Adjust track tension (WP 0108 00 or WP 0109 00).
- Step 4. If problem still exists, notify unit maintenance (VEHICLE MAKES THUMPING NOISE DURING TRAVEL).

VEHICLE SAGS TO ONE SIDE

- Step 1. Check for broken torsion bars (WP 0105 00).
 Notify unit maintenance.
- Step 2. If problem still exists, notify unit maintenance (VEHICLE SAGS TO ONE SIDE).

VEHICLE PULLS TO ONE SIDE WHEN NO STEERING IS APPLIED

- Step 1. Check track tension.
 Adjust track tension (WP 0108 00 or WP 0109 00).
- Step 2. If problem still exists, notify unit maintenance (VEHICLE PULLS TO ONE SIDE).

END OF TASK

VENTILATING BLOWER TROUBLESHOOTING

0102 00

THIS WORK PACKAGE COVERS:

Ventilating blower fails to operate properly. All other systems operate properly 0102 00

INITIAL SETUP:

Personnel Required

Three

VENTILATING BLOWER FAILS TO OPERATE PROPERLY. ALL OTHER SYSTEMS OPERATE PROPERLY

Step 1. Check if MASTER switch is ON.

Turn MASTER switch ON.

Step 2. Reset vent blower circuit breaker switch on PTO/Accessory panel.

Step 3. If problem still exists, notify unit maintenance (VENTILATING BLOWER FAILS TO OPERATE. ALL OTHER SYSTEMS OPERATE PROPERLY).

END OF TASK

WARNING SYSTEM TROUBLESHOOTING

0103 00

THIS WORK PACKAGE COVERS:

SYSTEM WARNING indicator will not come on when activating WINCH TEST switch 0103 00

INITIAL SETUP:

Personnel Required

Three

SYSTEM WARNING INDICATOR WILL NOT COME ON WHEN ACTIVATING WINCH TEST SWITCH

Step 1. Check lamp.

Replace lamp.

Step 2. If problem still exists, notify unit maintenance (SYSTEM WARNING INDICATOR WILL NOT COME ON WHEN ACTIVATING WINCH TEST SWITCH).

END OF TASK

WINCH ELECTRICAL SYSTEM TROUBLESHOOTING

0104 00

THIS WORK PACKAGE COVERS:

LEVEL WINDER MALFUNCTION indicator comes on	0104 00-1
PAYOUT LIMIT indicator comes on	0104 00-2
WINCH DRUM MALFUNCTION indicator comes on	0104 00-3
WINCH DRUM MALFUNCTION indicator lights, winch is operating properly	0104 00-4
WINCH PAYOUT LIMIT indicator lights, winch is operating properly	0104 00-4

INITIAL SETUP:

Personnel Required

Three

References

WP 0036 00

Personnel Required

Three

LEVEL WINDER MALFUNCTION INDICATOR COMES ON

Step 1. Check main winch cable for excessive fleet angle between level winder trumpet and disabled vehicle.

Position recovery vehicle to decrease fleet angle. Depending on ground conditions, it may be necessary to use the WINCH OVERRIDE switch and MAIN WINCH operating lever to get slack in the cable before realigning vehicle.

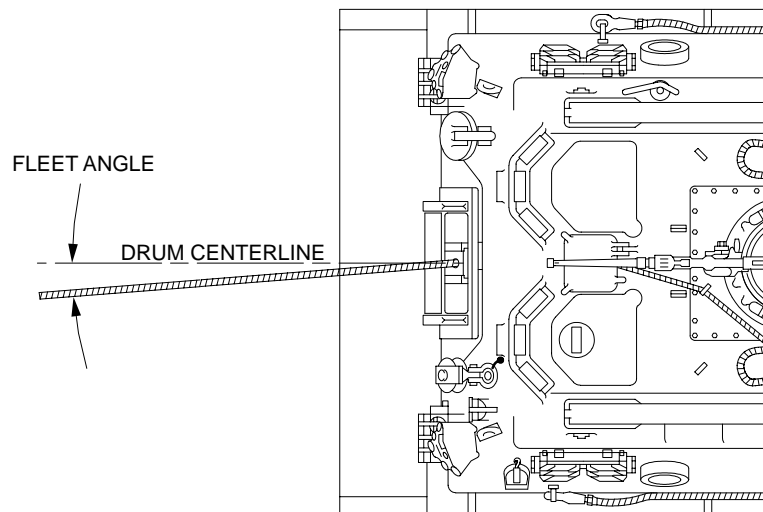

20i019t

Step 2. Check for obstructions to trumpet guide or level winder.

Remove obstructions.

WINCH ELECTRICAL SYSTEM TROUBLESHOOTING - CONTINUED

0104 00

LEVEL WINDER MALFUNCTION INDICATOR COMES ON - CONTINUED

Step 3. Remove floor plates. Check for hydraulic leaks at level winder. Check that quick-disconnect on hose 33 and 34 (hydraulics for level winder) is properly connected.

Connect quick-disconnect, tighten connections, or notify unit maintenance if there are any damaged hoses.

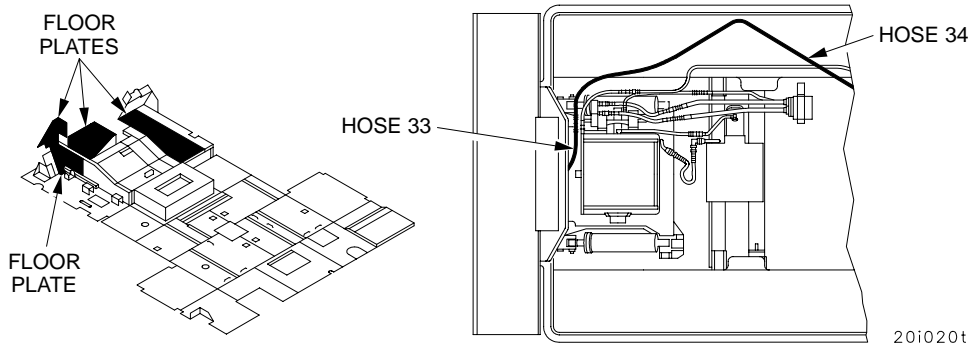

Check for cable problems including birdnesting, skipped wraps, kinks, broken strands, excess mud/debris build-up, misalignment between cable on drum and trumpet. Check for damage to level wind drive chain and sprockets. Remove two thumbscrews and raise diamond screw cover. Check for damage to level wind components, check for damaged/missing shoulder bolt or plate at the diamond screw/level wind interface.

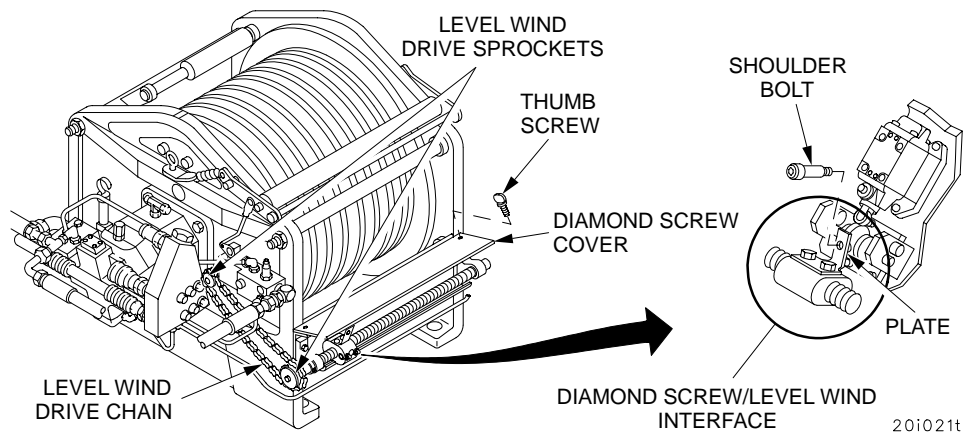

If there is damage to winch, level winder, cable, drive chain, or sprockets, or if shoulder bolt or plate is missing or damaged, do not operate winch. Notify unit maintenance.

Step 4. Use WINCH OVERRIDE switch and main winch operating lever to intermittently pay out and inhaul winch cable to make sure main winch cable is wrapping and unwrapping properly during inhaul and payout. Maintaining cable tension, use WINCH OVERRIDE switch and carefully payout main winch cable just past the point where spooling malfunction occurred. Correct spooling malfunction.

Step 5. If problem still exists, notify unit maintenance.

PAYOUT LIMIT INDICATOR COMES ON

Step 1. Check main winch to see if four wraps of cable are left on winch drum.

Move WINCH OVERRIDE switch to ON and INHAUL main winch cable until indicator goes out (one to one and a half wraps), then release WINCH OVERRIDE switch to OFF position.

Step 2. If problem still exists, notify unit maintenance (MAIN WINCH INHAULS BUT WILL NOT PAYOUT).

WINCH DRUM MALFUNCTION INDICATOR COMES ON

Step 1. Remove floor plates. Check for hydraulic leaks at level winder. Check that quick-disconnect on hose 33 and 34 (hydraulics for level winder) is properly connected.

Connect quick-disconnect, tighten connections, or notify unit maintenance if there are any damaged hoses.

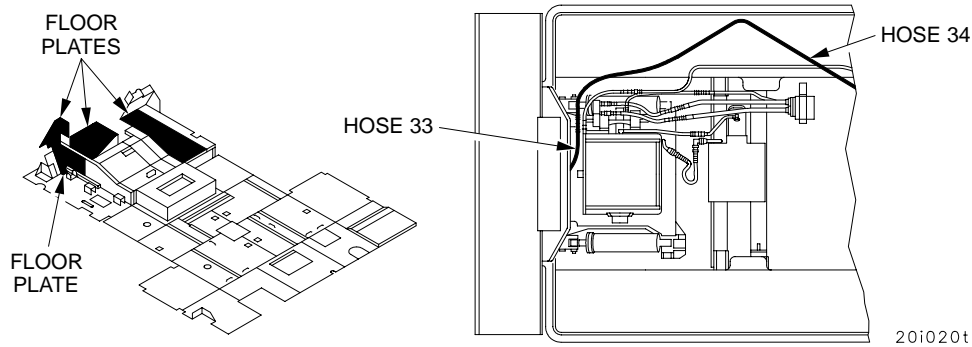

Check for cable problems including birdnesting, skipped wraps, kinks, broken strands, excess mud/debris buildup, misalignment between cable on drum and trumpet. Check for damage to level wind drive chain and sprockets. Remove two thumbscrews and raise diamond screw cover. Check for damage to level wind components, check damaged/missing shoulder bolt or plate at the diamond screw to level wind interface.

If there is damage to winch, level winder, cable, drive chain, or sprockets, or if shoulder bolt or plate is missing or damaged, do not operate winch. Notify unit maintenance.

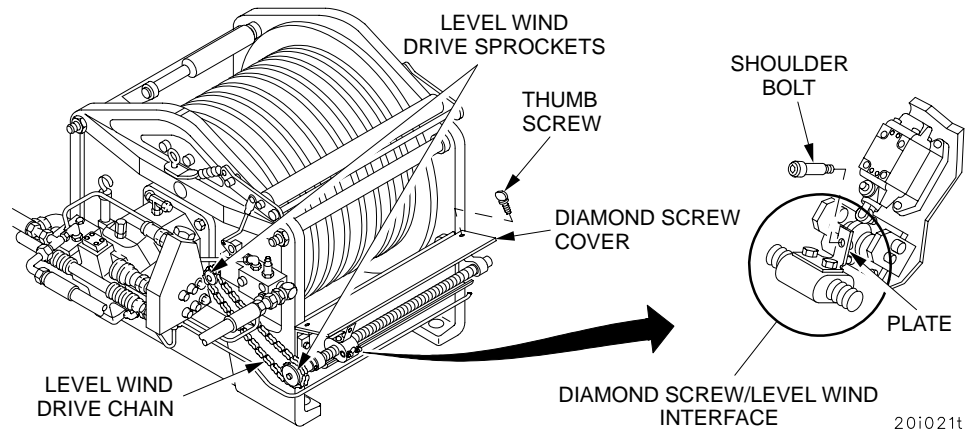

Step 2. Use WINCH OVERRIDE switch and main winch operating lever to intermittently pay out and inhaul winch cable to make sure main winch cable is wrapping and unwrapping properly during inhaul and payout. Maintaining cable tension, use WINCH OVERRIDE switch and carefully payout main winch cable just past the point where spooling malfunction occurred. Correct spooling malfunction.

Step 3. If problem still exists, notify unit maintenance.

WINCH ELECTRICAL SYSTEM TROUBLESHOOTING - CONTINUED

0104 00

WINCH DRUM MALFUNCTION INDICATOR LIGHTS, WINCH IS OPERATING PROPERLY

- Step 1. Remove subfloor plates under mechanic's seat and behind driver's seat (WP 0036 00).
- Step 2. Remove any dirt from winch drum microswitches and reset switch spools to rollers.
- Step 3. If problem still exists, notify unit maintenance (WINCH DRUM MALFUNCTION INDICATOR LIGHTS, WINCH IS OPERATING PROPERLY).

WINCH PAYOUT LIMIT INDICATOR LIGHTS, WINCH IS OPERATING PROPERLY

- Step 1. Remove subfloor plate under mechanic's seat (WP 0036 00).
- Step 2. Remove any dirt from payout microswitch and reset switch spool to roller.
- Step 3. If problem still exists, notify unit maintenance (WINCH PAYOUT LIMIT INDICATOR LIGHTS, WINCH IS OPERATING PROPERLY).

END OF TASK

CHAPTER 4

OPERATOR MAINTENANCE INSTRUCTIONS

**PREVENTIVE MAINTENANCE CHECKS AND SERVICES
INCLUDING LUBRICATION INSTRUCTIONS**

0105 00

THIS WORK PACKAGE COVERS:

Maintenance Forms and Records	0105 00-1
General Information	0105 00-1
Explanation of Table Entries	0105 00-1
Things to Remember While Doing PMCS	0105 00-2
Before (Table 1)	0105 00-4
During (Table 2)	0105 00-20
After (Table 3)	0105 00-30
Weekly (Table 4)	0105 00-59
Monthly (Table 5)	0105 00-69
Lubrication Instructions (Table 6)	0105 00-71

INITIAL SETUP:

Personnel Required

Three

References

DA PAM 738-750
DA Form 2404

WP 0135 00

Standard Form 368

MAINTENANCE FORMS AND RECORDS

Every mission begins and ends with paperwork. There isn't much of it, but you have to keep it up. The forms and records you fill out have several uses. They are a permanent record of services, repairs, and modifications made on your vehicle. They are reports to unit maintenance and to your commander. They are also checklists that tell you what is wrong with the equipment after its last use, and whether those faults have been repaired. For information on those forms and records, see DA PAM 738-750 (TAMMS).

GENERAL INFORMATION PREVENTIVE MAINTENANCE CHECKS AND SERVICES

1. General. Safe and efficient vehicle operation requires regular checks of equipment. When performing PMCS, the crew discovers malfunctions or performs routine maintenance for upkeep of the vehicle's systems. Malfunctions require corrective action to avoid equipment failure or injury to personnel. The suspension system requires special attention. Ensure that all lubrication tasks assigned to the crew in Table 6 are performed.
2. Warnings And Cautions. Always observe the WARNINGS and CAUTIONS appearing in the PMCS table. WARNINGS and CAUTIONS appear before applicable procedures. You must observe these WARNINGS and CAUTIONS to prevent serious injury to yourself or others or prevent equipment damage.

EXPLANATION OF TABLE ENTRIES

1. Item Number column. Numbers in this column are for reference. When completing DA Form 2404 (Equipment Inspection and Maintenance Worksheet), include the item number for the check/service indicating a fault. Item numbers also appear in the order that you must do checks and services for the intervals listed.
2. Interval column. This column tells you when you must do the procedure listed in the procedure column. BEFORE procedures must be done before you operate or use the equipment for its intended mission. DURING procedures must be done during the time you are operating the equipment for the intended mission. AFTER procedures must be done immediately after you have operated the equipment.
3. Location, Item to Check/Service column. This column provides the location and the item to be checked or serviced. The item location is underlined.
4. Procedure column. This column gives the procedure you must do to check or service the item listed in the Check/Service column to know if the equipment is ready or available for its intended mission or for operation. You must do the procedure at the time stated in the interval column.
5. Not Fully Mission Capable If: column. Information in this column tells you what faults will keep your equipment from being capable of performing its primary mission. If you determine that a fault exists on your vehicle as listed in this column, DO NOT OPERATE YOUR VEHICLE. Once a malfunction is identified, troubleshoot it using the instructions in this manual. If unable to correct the fault, write it on DA Form 2404 and notify unit maintenance immediately.

**PREVENTIVE MAINTENANCE CHECKS AND SERVICES INCLUDING
LUBRICATION INSTRUCTIONS - CONTINUED**

0105 00

THINGS TO REMEMBER WHILE DOING PMCS - CONTINUED**WARNING**

Do not operate vehicle with any class of fuel leak. Fuel may ignite causing serious bodily injury.

CAUTION

Equipment operation is allowable with minor leakage (Class I or II). Consideration must be given to the fluid capacity in the item/system being checked/inspected. When in doubt, notify the commander. When operating with Class I or Class II leaks, continue to check fluid levels as required in your PMCS. DO NOT operate vehicle with any class III leaks. Report class III leaks to the Vehicle Commander or unit maintenance.

Class I: Seepage of fluids as indicated by wetness or discoloration not great enough to form drops.

Class II: Leakage of fluid great enough to form drops, but not enough to cause drops to drip from item being checked/inspected.

Class III: Leakage of fluids great enough to form drops that fall from the item being checked/inspected.

PREVENTIVE MAINTENANCE CHECKS AND SERVICES INCLUDING LUBRICATION INSTRUCTIONS - CONTINUED

0105 00

TABLE 1 PREVENTIVE MAINTENANCE CHECKS AND SERVICES, BEFORE

INITIAL SETUP:

Tools and Special Tools

- Adjustable wrench (item 40, Table 2, WP 0133 00)
- Funnel (item 15, Table 2, WP 0133 00)
- Offset funnel (item 45, Table 2, WP 0133 00)
- Utility jug, measure and fill (item 46, Table 2, WP 0133 00)

Materials/Parts

- Lubricating oil, internal combustion (item 25, WP 0135 00)
- Wiping rags (item 45, WP 0135 00)

Personnel Required

Three

References

- WP 0017 00
- WP 0012 00
- WP 0133 00
- WP 0036 00
- WP 0135 00
- WP 0031 00
- WP 0122 00
- TM 9-1005-213-10
- TM 11-5820-890-10
- TM 11-5820-263-10
- TM 11-5820-340-12

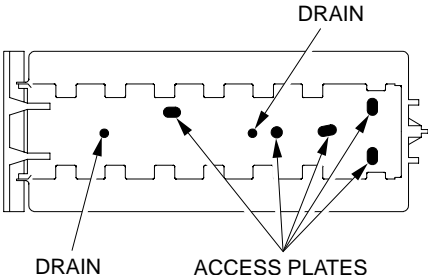
Item No.	Interval	LOCATION	CREWMEMBER Procedure	Not Fully Mission Capable If:
		Item to Check/Service		
1	Before	<u>EXTERIOR</u> Vehicle	<p><u>DRIVER</u></p> <p>Walk around vehicle. Check for fluid leakage, missing items or damage to equipment.</p>	Any fuel leaks. Any Class III oil or hydraulic fluid leak found. Vehicle has damage or is missing items that would make operation hazardous.
2	Before	Subfloor Drains and Access Plates	<p><u>DRIVER</u></p> <div style="border: 1px solid black; padding: 5px; text-align: center; margin: 10px 0;">CAUTION</div> <p>Do not ford if any drain or hull access plate is missing.</p> <p>Check that both hull drains and five access plates (including brake adjustment access covers) are present and secure.</p> <p style="text-align: center;">BOTTOM VIEW OF VEHICLE</p> <p style="text-align: center;">← FORWARD</p> 	Hull drains not closed or access plates (including brake adjustment access covers) are not present for operation.

18i213m

PREVENTIVE MAINTENANCE CHECKS AND SERVICES INCLUDING LUBRICATION INSTRUCTIONS - CONTINUED

0105 00

TABLE 1 PREVENTIVE MAINTENANCE CHECKS AND SERVICES, BEFORE-CONTINUED

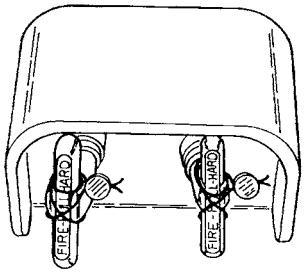
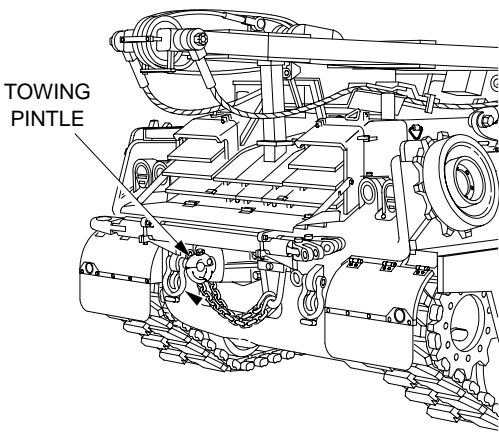
Item No.	Interval	LOCATION	CREWMEMBER Procedure	Not Fully Mission Capable If:
		Item to Check/ Service		
3	Before	External Fire Extinguisher Handle	<p><u>DRIVER</u></p> <p>Visually inspect for lead seals and locking wires.</p> 	<p>a. Missing or broken seals/wires.</p> <p>b. Missing or damaged handles.</p>
4	Before	Tow Pintle	<p><u>DRIVER</u></p> <p>Inspect tow pintle for damage, or missing parts.</p>  <p style="text-align: right;">18i060mb</p>	<p>Cracks, damage, or parts missing.</p>

PREVENTIVE MAINTENANCE CHECKS AND SERVICES INCLUDING LUBRICATION INSTRUCTIONS - CONTINUED

0105 00

TABLE 1 PREVENTIVE MAINTENANCE CHECKS AND SERVICES, BEFORE-CONTINUED

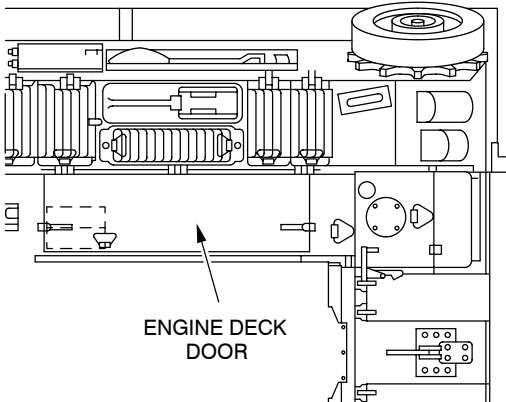
Item No.	Interval	LOCATION	CREWMEMBER Procedure	Not Fully Mission Capable If:
		Item to Check/ Service		
5	Before	<p><u>ENGINE COMPARTMENT</u></p> <p>Engine Oil Level Check</p>	<p><u>DRIVER</u></p> <div style="text-align: center; border: 1px solid black; padding: 5px; width: fit-content; margin: 10px auto;"> CAUTION </div> <p>Perform engine oil check with vehicle on a level surface and engine stopped for at least two hours.</p> <p>Do not use ENG. IDLING RANGE side of oil gauge rod to measure engine oil level. Use of ENG. IDLING RANGE side of oil gauge rod could result in equipment damage.</p> <p>a. Park vehicle on a level surface for at least two hours.</p> <p>b. Open engine deck door (WP 0031 00).</p> <div style="text-align: center; margin-top: 20px;"> <p>← FORWARD</p>  <p style="text-align: right; font-size: small;">18i057mb</p> </div>	

PREVENTIVE MAINTENANCE CHECKS AND SERVICES INCLUDING LUBRICATION INSTRUCTIONS - CONTINUED

0105 00

TABLE 1 PREVENTIVE MAINTENANCE CHECKS AND SERVICES, BEFORE-CONTINUED

Item No.	Interval	LOCATION	CREWMEMBER Procedure	Not Fully Mission Capable If:
		Item to Check/ Service		
5 cont	Before	Engine Oil Level Check - Continued	<p><u>DRIVER</u></p> <p>c. Open ENGINE OIL LEVEL check and fill access door.</p> <p>d. Open ENGINE OIL LEVEL DOOR.</p> <p>e. Remove oil gauge rod and wipe clean. Insert oil gauge rod in gauge tube. Remove oil gauge rod. Verify oil level on STATIC ENG. side of oil gauge rod is between FULL and 1-gallon range.</p>	

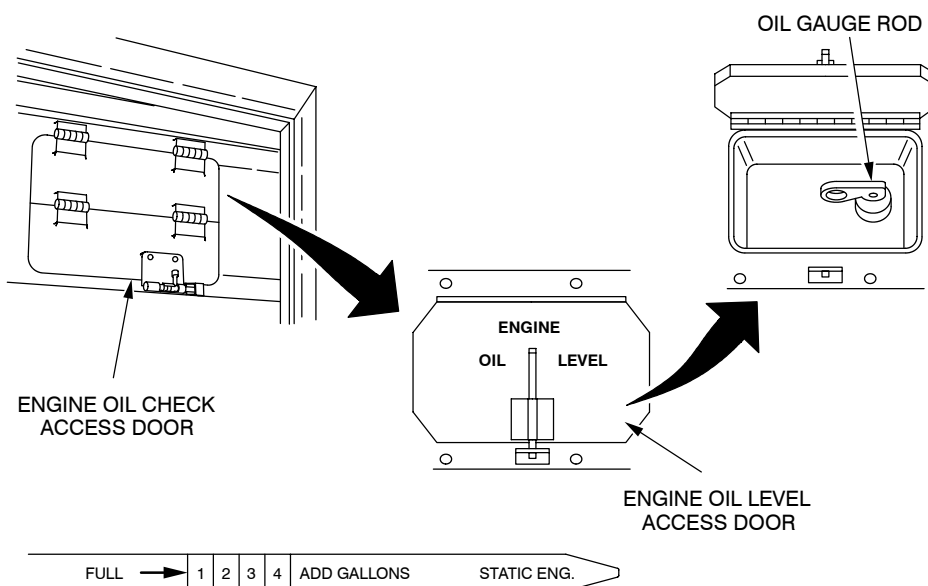

181057mi

WARNING

Engine oil can be ignited by hot engine surfaces. To avoid engine fire, use offset funnel (item 45, Table 2, WP 0133 00) and utility jug (item 46, Table 2, WP 0133 00) to add engine oil, clean oil from around oil filler tube area with wiping rags (item 45, WP 0135 00) after filling. Make sure engine oil filler tube cap is tight and engine oil fill access door is closed and latched.

PREVENTIVE MAINTENANCE CHECKS AND SERVICES INCLUDING LUBRICATION INSTRUCTIONS - CONTINUED

0105 00

TABLE 1 PREVENTIVE MAINTENANCE CHECKS AND SERVICES, BEFORE-CONTINUED

Item No.	Interval	LOCATION	CREWMEMBER Procedure	Not Fully Mission Capable If:
		Item to Check/ Service		
5 cont	Before	Engine Oil Level Check - Continued	<u>DRIVER</u> f. If oil level is below FULL, add the amount in gallons indicated on the oil gauge rod. To add proper grade oil (Table 6, WP 0105 00) open engine oil fill access door, add oil through engine oil filler tube using offset funnel (item 45, Table 2, WP 0133 00) and utility jug (item 46, Table 2, WP 0133 00).	

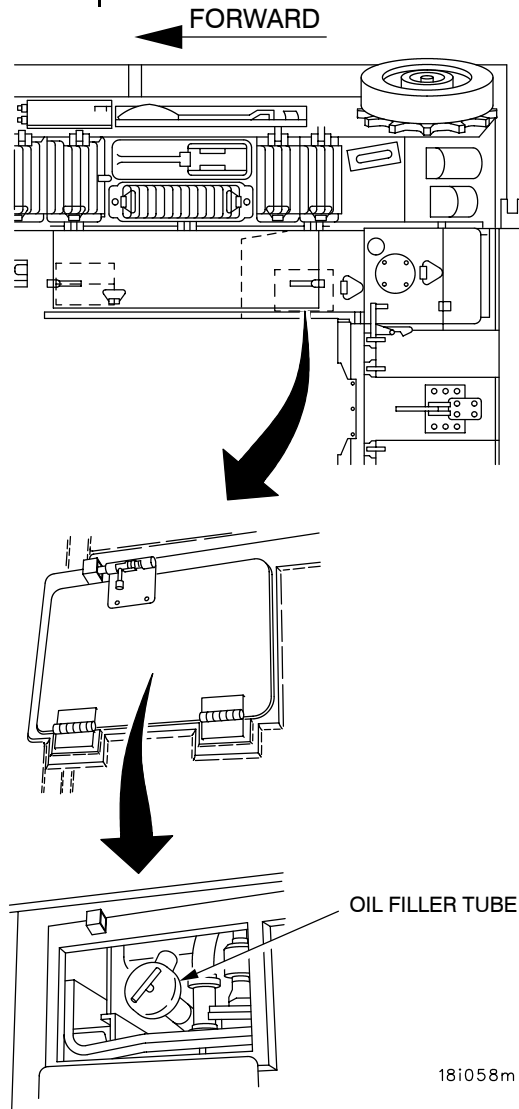

PREVENTIVE MAINTENANCE CHECKS AND SERVICES INCLUDING LUBRICATION INSTRUCTIONS - CONTINUED

0105 00

TABLE 1 PREVENTIVE MAINTENANCE CHECKS AND SERVICES, BEFORE-CONTINUED

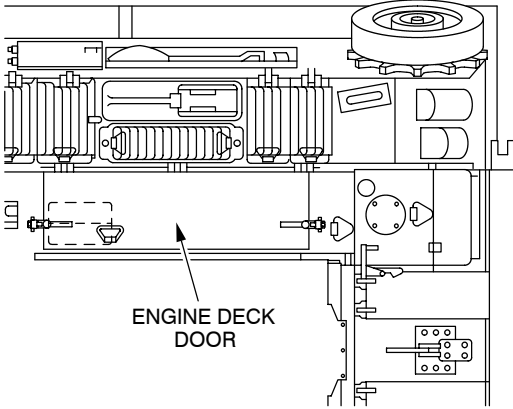
Item No.	Interval	LOCATION	CREWMEMBER Procedure	Not Fully Mission Capable If:
		Item to Check/ Service		
6	Before	<u>ENGINE COMPARTMENT</u>	<p><u>DRIVER</u></p> <div style="border: 1px solid black; padding: 5px; text-align: center; margin: 10px 0;">CAUTION</div> <p>Perform engine oil check with vehicle on a level surface and engine stopped for at least two hours.</p> <p>Do not use ENG. IDLING RANGE side of oil gauge rod to measure engine oil level. Use of ENG. IDLING RANGE side of oil gauge rod could result in equipment damage.</p> <p>a. Park vehicle on a level surface for at least two hours.</p> <p>b. Open engine deck door (WP 0031 00).</p> <div style="text-align: center; margin: 10px 0;"> <p>← FORWARD</p>  </div> <p style="text-align: right; font-size: small;">18i057mb</p>	
		Engine Oil Level Check (New)		

PREVENTIVE MAINTENANCE CHECKS AND SERVICES INCLUDING LUBRICATION INSTRUCTIONS - CONTINUED

0105 00

TABLE 1 PREVENTIVE MAINTENANCE CHECKS AND SERVICES, BEFORE-CONTINUED

Item No.	Interval	LOCATION	CREWMEMBER Procedure	Not Fully Mission Capable If:
		Item to Check/ Service		
6 cont	Before	Engine Oil Level Check (New) - Continued	<p><u>DRIVER</u></p> <p>c. Open ENGINE OIL LEVEL check and fill access door.</p> <p>d. Remove oil gauge rod and wipe clean. Insert oil gauge rod in gauge tube. Remove oil gauge rod. Verify oil level on STATIC ENG. side of oil gauge rod is between FULL and 1-gallon range.</p>	

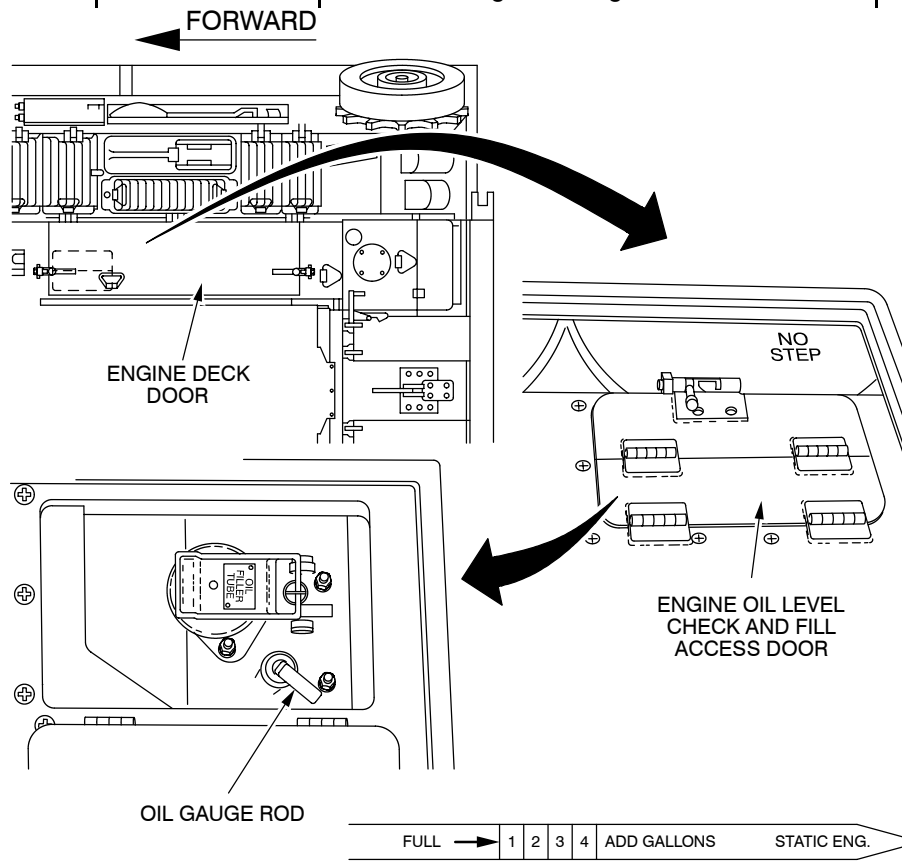

18i057mj

WARNING

Engine oil can be ignited by hot engine surfaces. To avoid engine fire, use offset funnel (item 45, Table 2, WP 0133 00) and utility jug (item 46, Table 2, WP 0133 00) to add engine oil, clean oil from around oil filler tube area with wiping rags (item 45, WP 0135 00) after filling. Make sure engine oil filler tube cap is closed and engine oil fill access door is closed and latched.

PREVENTIVE MAINTENANCE CHECKS AND SERVICES INCLUDING LUBRICATION INSTRUCTIONS - CONTINUED

0105 00

TABLE 1 PREVENTIVE MAINTENANCE CHECKS AND SERVICES, BEFORE-CONTINUED

Item No.	Interval	LOCATION	CREWMEMBER Procedure	Not Fully Mission Capable If:
		Item to Check/ Service		
6 cont	Before	Engine Oil Level Check (New) - Continued	<p>e. If oil level is below FULL, add the amount in gallons indicated on the oil gauge rod (Table 6, WP 0105 00). To add proper grade oil:</p> <p>f. Pull up on engine oil filler tube cap handle and open engine oil filler tube.</p> <p>g. Insert offset funnel (item 45, Table 2, WP 0133 00) in oil filler tube.</p> <p>h. Pour quantity of oil as indicated on gauge rod into graduated 2.5 gallon utility jug (item 46, Table 2, WP 0133 00).</p> <p>i. Pour oil into engine. Close oil filler tube cap and all access doors.</p>	

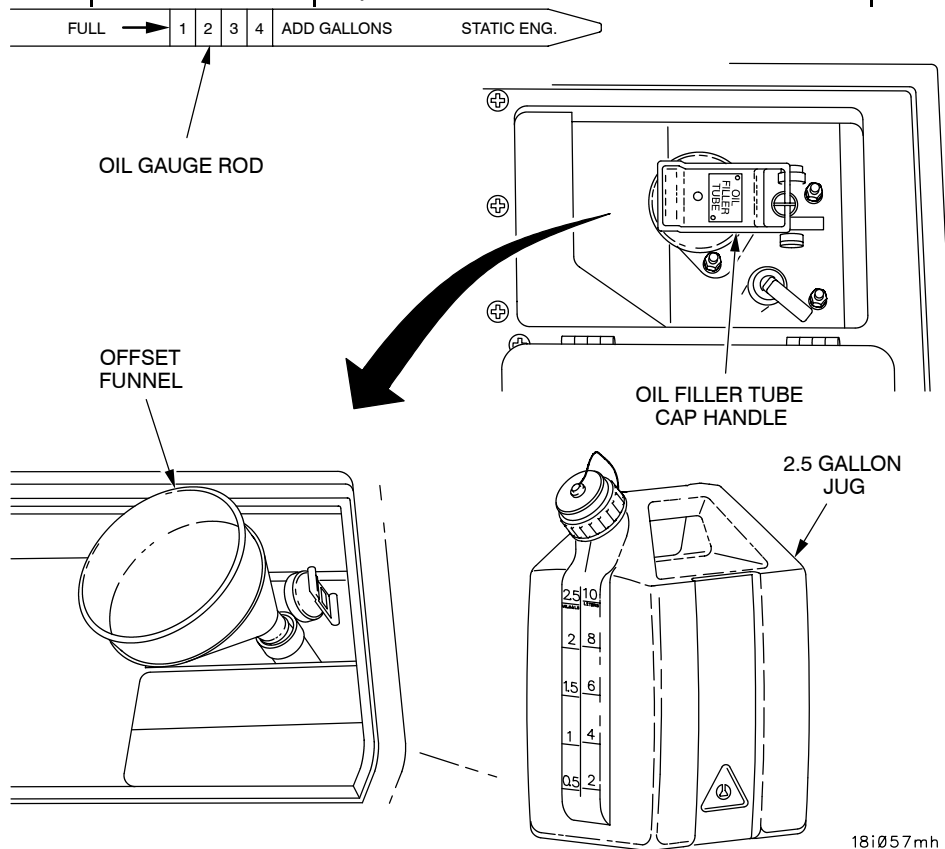

PREVENTIVE MAINTENANCE CHECKS AND SERVICES INCLUDING LUBRICATION INSTRUCTIONS - CONTINUED

0105 00

TABLE 1 PREVENTIVE MAINTENANCE CHECKS AND SERVICES, BEFORE-CONTINUED

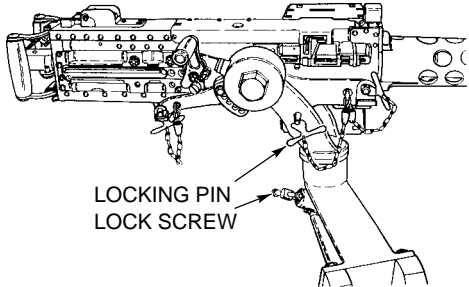
Item No.	Interval	LOCATION	CREWMEMBER Procedure	Not Fully Mission Capable If:
		Item to Check/ Service		
7	Before	Machine gun and Mount	<p><u>COMMANDER</u></p> <p>NOTE</p> <p>For detailed instructions on the maintenance of the M2 caliber .50 machine gun mount see TM 9-1005-213-10.</p> <ol style="list-style-type: none"> Remove locking pin and loosen lock screw. Check that machine gun mount moves freely. 	<ol style="list-style-type: none"> Cannot be locked down. Does not move or rotate freely.

PREVENTIVE MAINTENANCE CHECKS AND SERVICES INCLUDING LUBRICATION INSTRUCTIONS - CONTINUED

0105 00

TABLE 1 PREVENTIVE MAINTENANCE CHECKS AND SERVICES, BEFORE-CONTINUED

Item No.	Interval	LOCATION	CREWMEMBER Procedure	Not Fully Mission Capable If:
		Item to Check/ Service		
8	Before	<p><u>CREW COMPARTMENT</u></p> <p>Fixed Fire Extinguisher System</p>	<p><u>DRIVER</u></p> <p>a. Inspect pins, heads, connecting tubes and controls for broken seals, tightness and for serviceable condition. Check pins, cylinder heads and connect tubes for looseness, cracking or evidence of damage. Check inspection tags for current inspection of cylinders.</p> <p>b. Check internal pull handles for damage. Check that seals' locking wires are not broken or missing.</p> <p>c. Check distribution lines for loose fittings, tight mountings, and cracks.</p>	<p>a. Seals broken or missing. Any fixed fire extinguisher cylinder missing or discharged. Out of date inspection tag.</p> <p>b. Any damaged handles, broken or missing seals or locking wires.</p> <p>c. Distribution lines, loose, cracked or mounting not tight.</p>

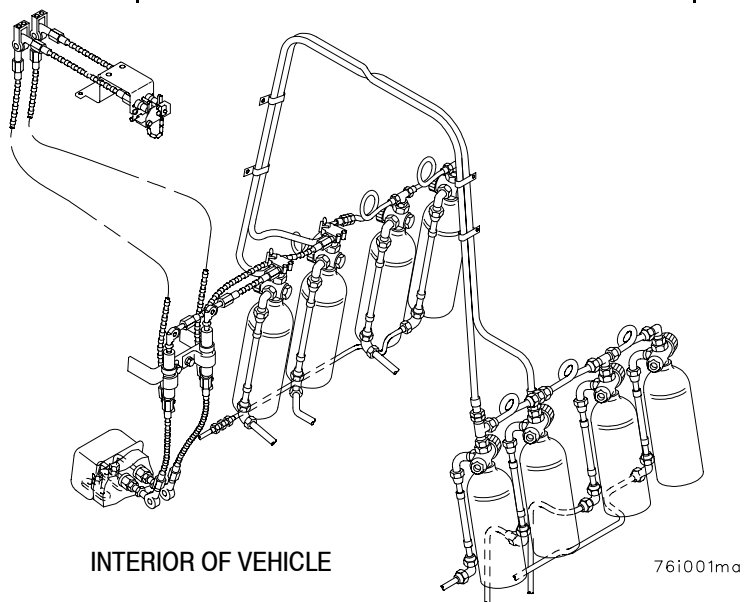

PREVENTIVE MAINTENANCE CHECKS AND SERVICES INCLUDING LUBRICATION INSTRUCTIONS - CONTINUED

0105 00

TABLE 1 PREVENTIVE MAINTENANCE CHECKS AND SERVICES, BEFORE-CONTINUED

Item No.	Interval	LOCATION	CREWMEMBER Procedure	Not Fully Mission Capable If:
		Item to Check/ Service		
9	Before	Hoist Winch Oil Level	<p><u>COMMANDER</u></p> <p>Park vehicle on a level surface. Open subfloor access door (WP 0036 00).</p> <p>Verify oil level is between the middle and top of the sight gauge.</p> <p style="text-align: center;">NOTE</p> <p>Do not fill above top of sight gauge, as correct oil level cannot be determined.</p> <p>If oil is below the middle of the sight gauge, remove the vent/fill plug and add proper grade oil (Table 6, WP 0105 00) until the oil level is between the middle and top of the sight gauge. Install vent/fill plug when oil is at correct level.</p>	Class III oil leaks.

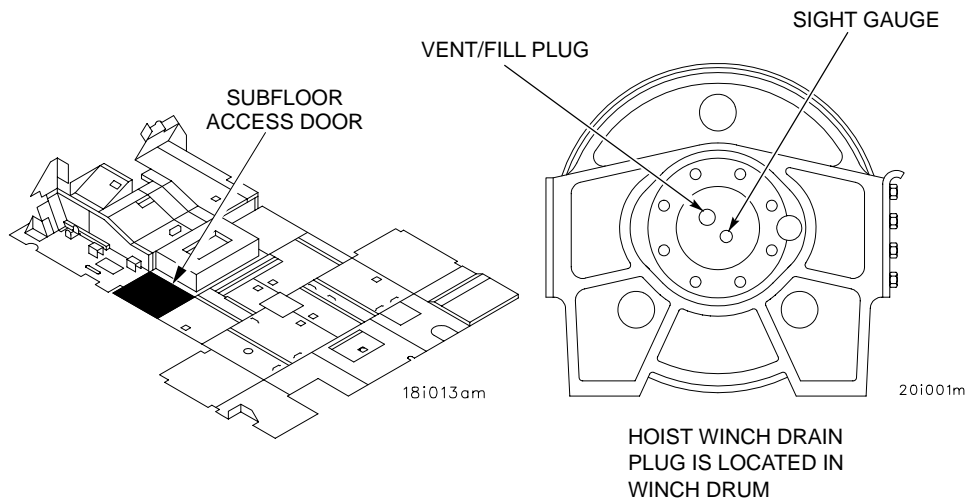

PREVENTIVE MAINTENANCE CHECKS AND SERVICES INCLUDING LUBRICATION INSTRUCTIONS - CONTINUED

0105 00

TABLE 1 PREVENTIVE MAINTENANCE CHECKS AND SERVICES, BEFORE-CONTINUED

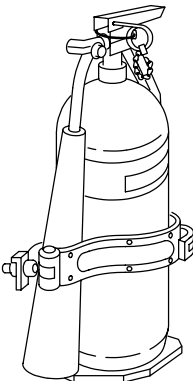
Item No.	Interval	LOCATION	CREWMEMBER Procedure	Not Fully Mission Capable If:
		Item to Check/ Service		
10	Before	Portable Fire Extinguishers	<p><u>COMMANDER</u></p> <p>a. Check portable fire extinguisher's control seals. Make sure seals or locking wires are not broken.</p> <p>b. Check fire extinguishers for security of mounting hardware and missing hardware.</p> <p>c. Check inspection tags for current inspection date of cylinders.</p> <div style="text-align: center;">  </div> <p>NOTE</p> <p>Refer to TM 11-5820-890-10 (AN/VIC-1(V)) or TM 11-5830-263-10 (AN/VIC-3(V)) and TM 11-5830-340-12 for radio operational checks.</p>	<p>a. Any fire extinguisher missing. Seal or lockwire missing or broken.</p> <p>b. Inspection tag not current.</p>
11	Before	Intercommunications System and Radio Sets	<p>a. Check intercommunication system operation.</p> <p>b. Check for unusual noises, interference or poor operation in general. Report all problems to unit maintenance.</p>	<p>No means of communication between driver and commander.</p>

PREVENTIVE MAINTENANCE CHECKS AND SERVICES INCLUDING LUBRICATION INSTRUCTIONS - CONTINUED

0105 00

TABLE 1 PREVENTIVE MAINTENANCE CHECKS AND SERVICES, BEFORE-CONTINUED

Item No.	Interval	LOCATION	CREWMEMBER Procedure	Not Fully Mission Capable If:
		Item to Check/ Service		
12	Before	Gauge Panel	<p><u>DRIVER</u></p> <div style="border: 2px solid black; padding: 5px; text-align: center; margin: 10px 0;">WARNING</div> <p>Make sure steering wheel is centered and locked. Vehicle may move during engine starting causing injury to personnel.</p> <p>Engine must be started and operated at normal temperature to check gauges. Start engine (WP 0012 00).</p> <p style="text-align: center;">NOTE</p> <p>Engine may take longer to warm-up depending on climatic conditions.</p> <p>Check all gauges on gauge panel for damage and the following gauges for indicators of normal operations:</p> <ol style="list-style-type: none"> a. Engine oil PRESS gauge (1) normal pressure range 40-70 psi (276 kPa - 483 kPa) at 2400 rpm and 180°F (82°C) oil temperature. b. TRANSMISSION oil PRESS gauge (2) normal pressure 17 psi (117 kPa). c. BATT-GEN gauge (3) normal indication - green zone for generator or yellow zone for batteries. d. Tachometer (4) should operate normally without excessive fluctuations or unusual noises. 	<p>Any gauge is missing, fluctuating or inoperative.</p> <p>BATT/GEN gauge not in green zone.</p>

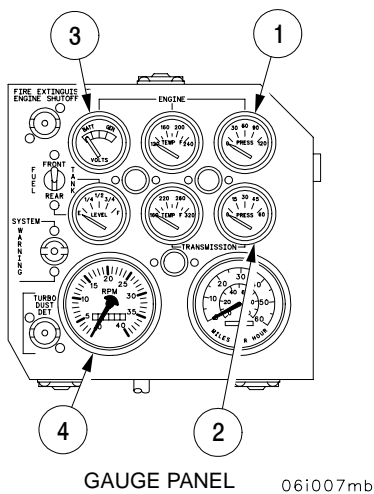

PREVENTIVE MAINTENANCE CHECKS AND SERVICES INCLUDING LUBRICATION INSTRUCTIONS - CONTINUED

0105 00

TABLE 1 PREVENTIVE MAINTENANCE CHECKS AND SERVICES, BEFORE-CONTINUED

Item No.	Interval	LOCATION	CREWMEMBER Procedure	Not Fully Mission Capable If:
		Item to Check/Service		
13	Before	Indicator Lamp Test	<p>DRIVER Check that all warning indicator lamps work.</p> <p>a. Move LAMP TEST switch up and verify that all indicators on the PTO/Accessory panel and hydraulic control panel light.</p> <p>b. Move WINCH TEST toggle switch to TEST and verify that SYSTEM WARNING indicator comes on, and system warning horn sounds.</p>	<p>a. Any warning indicator will not light.</p> <p>b. SYSTEM WARNING indicator does not come on.</p>

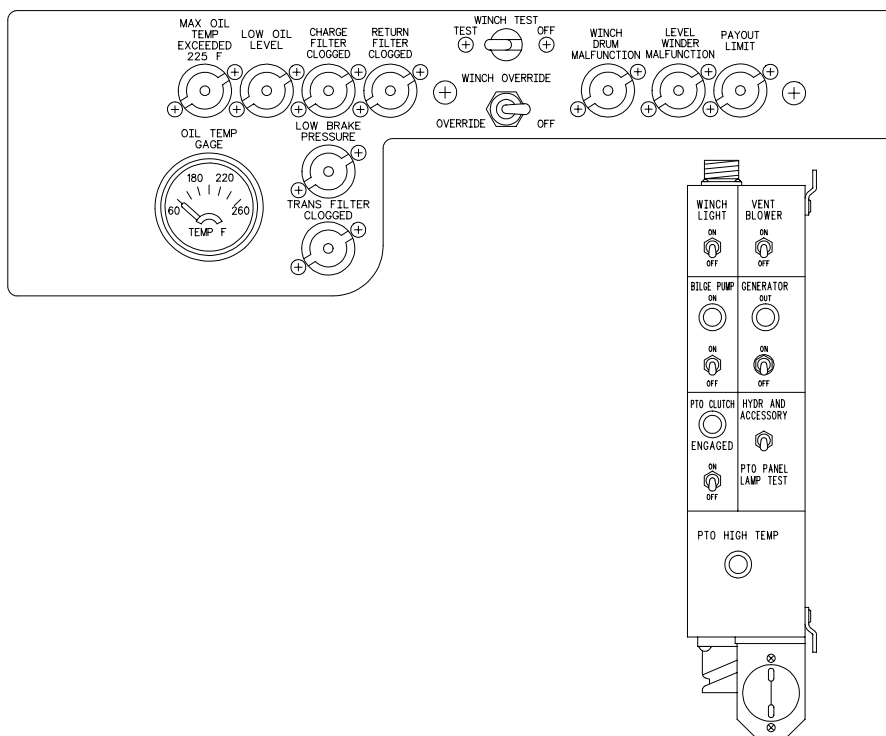

06i011mb

PREVENTIVE MAINTENANCE CHECKS AND SERVICES INCLUDING LUBRICATION INSTRUCTIONS - CONTINUED

0105 00

TABLE 1 PREVENTIVE MAINTENANCE CHECKS AND SERVICES, BEFORE-CONTINUED

Item No.	Interval	LOCATION	CREWMEMBER Procedure	Not Fully Mission Capable If:
		Item to Check/ Service		
14	Before	Brakes	<p><u>DRIVER</u></p> <p style="text-align: center;">NOTE</p> <p>Perform Item number 14a only if vehicle is equipped with brake bleed valve and gauge (new configuration) or modified brake pedal/modulation valve and higher operating pressure (new configuration with brake modulation or new configuration with brake modulation and enhanced parking brake).</p> <p>a. Observe brake pressure gauge (1). Approximately 25 seconds after the main engine is started the gauge should indicate 950 psi (new configuration) or 1300 psi (new configuration with brake modulation and new configuration with brake modulation and enhanced parking brake).</p> <p>b. If gauge (1) indicates below 950 psi (new configuration) or 1100 psi (new configuration with brake modulation or new configuration with brake modulation and enhanced parking brake) and brake pump motor runs continuously bleed air from brake lines (WP 0122 00).</p>	<p>Brake pressure does not reach 950 psi (new configuration) and brake pump motor runs continuously. Brake pressure does not reach 1100 to 1300 psi (new configuration with brake modulation or new configuration with brake modulation and enhanced parking brake) and brake pump motor runs continuously.</p>
15	Before	Brakes	<p><u>DRIVER</u></p> <p>Move vehicle forward and apply brakes to see if vehicle stops or pedal binds (WP 0017 00).</p>	<p>Brakes are inoperative.</p>

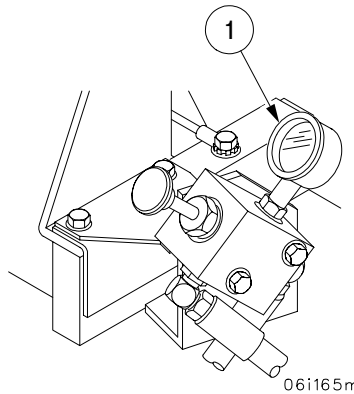

END OF TASK

PREVENTIVE MAINTENANCE CHECKS AND SERVICES INCLUDING LUBRICATION INSTRUCTIONS - CONTINUED

0105 00

TABLE 2 PREVENTIVE MAINTENANCE CHECKS AND SERVICES, DURING

INITIAL SETUP:

Tools and Special Tools

- Funnel (item 15, Table 2, WP 0133 00)
- Offset funnel (item 45, Table 2, WP 0133 00)
- Utility jug (item 46, Table 2, WP 0133 00)

References

- WP 0031 00 WP 0045 00
- WP 0133 00 WP 0047 00
- WP 0135 00 WP 0048 00
- WP 0046 00 WP 0049 00
- WP 0116 00 WP 0050 00

Materials/Parts

- Lubricating oil, internal combustion (item 25, WP 0135 00)
- Wiping rags (item 45, WP 0135 00)

Personnel Required

Three

Item No.	Interval	LOCATION	<u>CREWMEMBER</u> Procedure	Not Fully Mission Capable If:
		Item to Check/Service		
1	During	Controls: Steering, Shift, Accelerator and Brake.	<p><u>DRIVER</u></p> <p>a. Operate steering controls and note any binding or excessive play.</p> <p>b. Operate shift controls and note any binding or excessive play.</p> <p>c. Operate accelerator pedal and note any binding or excessive play.</p> <p>d. Operate brake pedal and note any binding or excessive play.</p>	<p>a. Binding or excessive play in steer controls.</p> <p>b. Binding or excessive play in shift controls.</p> <p>c. Binding or excessive play in accelerator pedal.</p> <p>d. Binding or excessive play in brake pedal.</p>

PREVENTIVE MAINTENANCE CHECKS AND SERVICES INCLUDING LUBRICATION INSTRUCTIONS - CONTINUED

0105 00

TABLE 2 PREVENTIVE MAINTENANCE CHECKS AND SERVICES, DURING-CONTINUED

Item No.	Interval	LOCATION	CREWMEMBER Procedure	Not Fully Mission Capable If:
		Item to Check/Service		
2	During	Unusual Noises	<p><u>DRIVER</u></p> <p>Be alert for unusual noises, odors or visual indications of problems in the engine, transmission, suspension or hydraulic systems.</p> <p><u>DRIVER/MECHANIC</u></p>  <p>WARNING</p> <p>WARNING</p> <p>Ensure all safety pins and bolts are in place and secure prior to any lifting, towing, or winching operation.</p>	
3	During	Hydraulic System, Boom, Main Winch, Hoist Winch, Auxiliary Winch, and Spade	<p>Engage main hydraulic system to determine operation of controls and pumps (WP 0045 00).</p> <p>During operation be alert for any unusual noises or vibrations.</p> <p>Check operation of main, hoist and auxiliary winches; boom, spade, and spade lock (WP 0048 00, WP 0047 00, WP 0049 00, WP 0046 00 and WP 0050 00).</p>	Hydraulic system inoperative; improper performance or malfunction; class III oil leaks; any winch, boom, spade or spade lock inoperative.
4	During	Gauge Panels	<p>Monitor following gauges:</p> <ol style="list-style-type: none"> ENGINE oil TEMP gauge (1) normal temperature range 160°F-230°F (71°C-140°C). TRANSMISSION oil TEMP gauge (2) normal temperature range 160°F-260°F (71°C-127°C). ENGINE oil PRESS gauge (3) normal pressure range 40-70 psi (276 kPa-6201 kPa) at 2400 rpm and 180°F(82°C) oil temperature. TRANSMISSION oil PRESS gauge (4) normal pressure 17 psi (117 kPa). 	Any gauge is missing, fluctuating or inoperative.

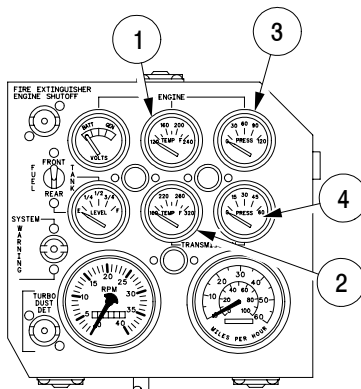

GAUGE PANEL 06i007mc

PREVENTIVE MAINTENANCE CHECKS AND SERVICES INCLUDING LUBRICATION INSTRUCTIONS - CONTINUED

0105 00

TABLE 2 PREVENTIVE MAINTENANCE CHECKS AND SERVICES, DURING-CONTINUED

Item No.	Interval	LOCATION	CREWMEMBER Procedure	Not Fully Mission Capable If:
		Item to Check/ Service		
5	During	<u>ENGINE COMPARTMENT</u>	<p><u>DRIVER</u></p> <div style="border: 1px solid black; padding: 5px; text-align: center; width: fit-content; margin: 10px auto;">CAUTION</div> <p>This engine oil level check method should only be used when it is impractical to wait at least two hours with the engine stopped.</p> <p style="text-align: center;">NOTE</p> <p>Check oil level during extended missions at least every 8 hours with engine running. Verify oil level using engine stopped method (Table 6, WP 0105 00) as soon as possible.</p> <p>Engine must be idling for at least 5 minutes and oil temperature is less than 140°F (60°C).</p> <p>a. Park vehicle on a level surface. b. Open engine deck door (WP 0031 00).</p>	
		Engine Oil Level Check		

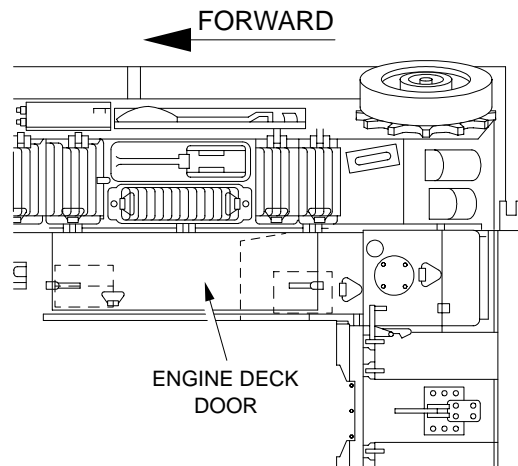

18i057ma

PREVENTIVE MAINTENANCE CHECKS AND SERVICES INCLUDING LUBRICATION INSTRUCTIONS - CONTINUED

0105 00

TABLE 2 PREVENTIVE MAINTENANCE CHECKS AND SERVICES, DURING-CONTINUED

Item No.	Interval	LOCATION	CREWMEMBER Procedure	Not Fully Mission Capable If:
		Item to Check/Service		
5 cont	During	Engine Oil Level Check - Continued	<p><u>DRIVER</u></p> <p>c. Open engine oil check access door.</p> <p>d. Open ENGINE OIL LEVEL door.</p> <p>e. Remove oil gauge rod and wipe clean. Insert oil gauge rod in gauge tube. Remove oil gauge rod. Verify oil level on ENG. IDLING RANGE side of oil gauge rod is within ENG. IDLING RANGE marks.</p>	

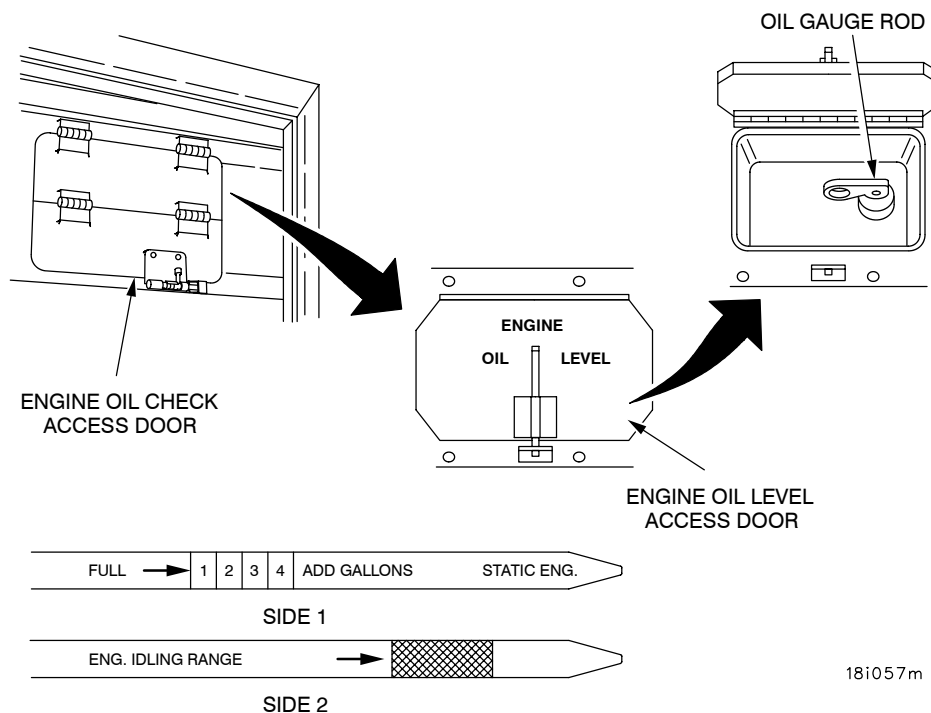

18i057m

WARNING

Engine oil can be ignited by hot engine surfaces. To avoid engine fire, use offset funnel (item 45, Table 2, WP 0133 00) and utility jug (item 46, Table 2, WP 0133 00) to add engine oil, clean oil from around oil filler tube area with wiping rags (item 45, WP 0135 00) after filling. Make sure engine oil filler tube cap is tight and engine oil fill access door is closed and latched.

PREVENTIVE MAINTENANCE CHECKS AND SERVICES INCLUDING LUBRICATION INSTRUCTIONS - CONTINUED

0105 00

TABLE 2 PREVENTIVE MAINTENANCE CHECKS AND SERVICES, DURING-CONTINUED

Item No.	Interval	LOCATION	CREWMEMBER Procedure	Not Fully Mission Capable If:
		Item to Check/Service		
5 cont	During	Engine Oil Level Check - Continued	<p><u>DRIVER</u></p> <p>f. To add proper grade oil (Table 6, WP 0105 00) open engine oil fill access door, add oil through engine oil filler tube using offset funnel (item 45, Table 2, WP 0133 00) and utility jug (item 46, Table 2, WP 0133 00).</p>	

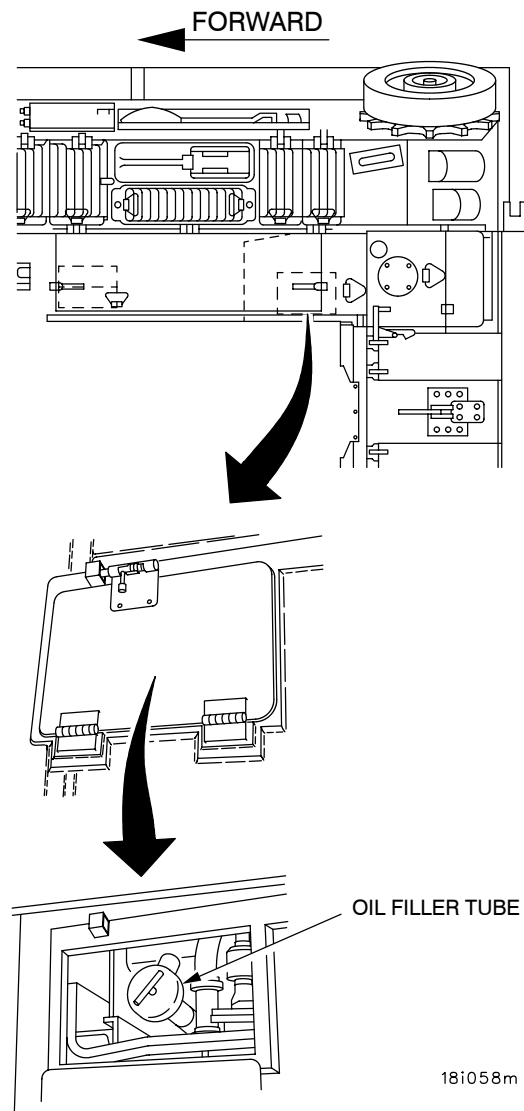

PREVENTIVE MAINTENANCE CHECKS AND SERVICES INCLUDING LUBRICATION INSTRUCTIONS - CONTINUED

0105 00

TABLE 2 PREVENTIVE MAINTENANCE CHECKS AND SERVICES, DURING-CONTINUED

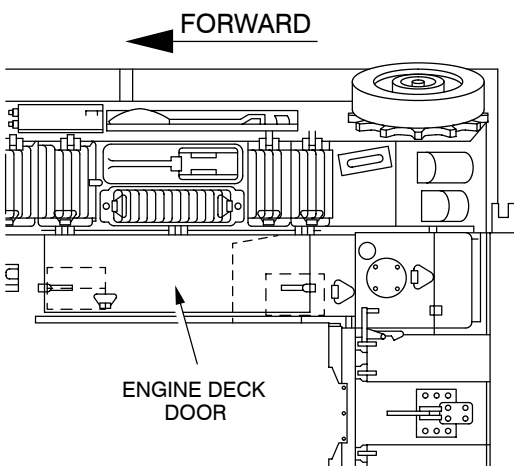
Item No.	Interval	LOCATION	CREWMEMBER Procedure	Not Fully Mission Capable If:
		Item to Check/ Service		
6	During	<u>ENGINE COMPARTMENT</u>	<p><u>DRIVER</u></p> <div style="text-align: center;"> <p>CAUTION</p> <p>This engine oil level check method should only be used when it is impractical to wait at least two hours with the engine stopped.</p> <p>NOTE</p> <p>Check oil level during extended missions at least every 8 hours with engine running. Verify oil level using engine stopped method (Table 6, WP 0105 00) as soon as possible.</p> <p>Engine must be idling for at least 5 minutes and oil temperature is less than 140° F (60° C).</p> <p>a. Park vehicle on a level surface. b. Open engine deck door (WP 0031 00).</p> </div>  <p style="text-align: right;">18i057mk</p>	
		Engine Oil Level Check (New)		

PREVENTIVE MAINTENANCE CHECKS AND SERVICES INCLUDING LUBRICATION INSTRUCTIONS - CONTINUED

0105 00

TABLE 2 PREVENTIVE MAINTENANCE CHECKS AND SERVICES, DURING-CONTINUED

Item No.	Interval	LOCATION	CREWMEMBER Procedure	Not Fully Mission Capable If:
		Item to Check/ Service		
6 cont	During	Engine Oil Level Check (New) - Continued	<p><u>DRIVER</u></p> <p>c. Open engine oil check access door.</p> <p>d. Remove oil gauge rod and wipe clean. Insert oil gauge rod in gauge tube. Remove oil gauge rod. Verify oil level on ENG. IDLING RANGE side of oil gauge rod is within ENG. IDLING RANGE marks.</p>	

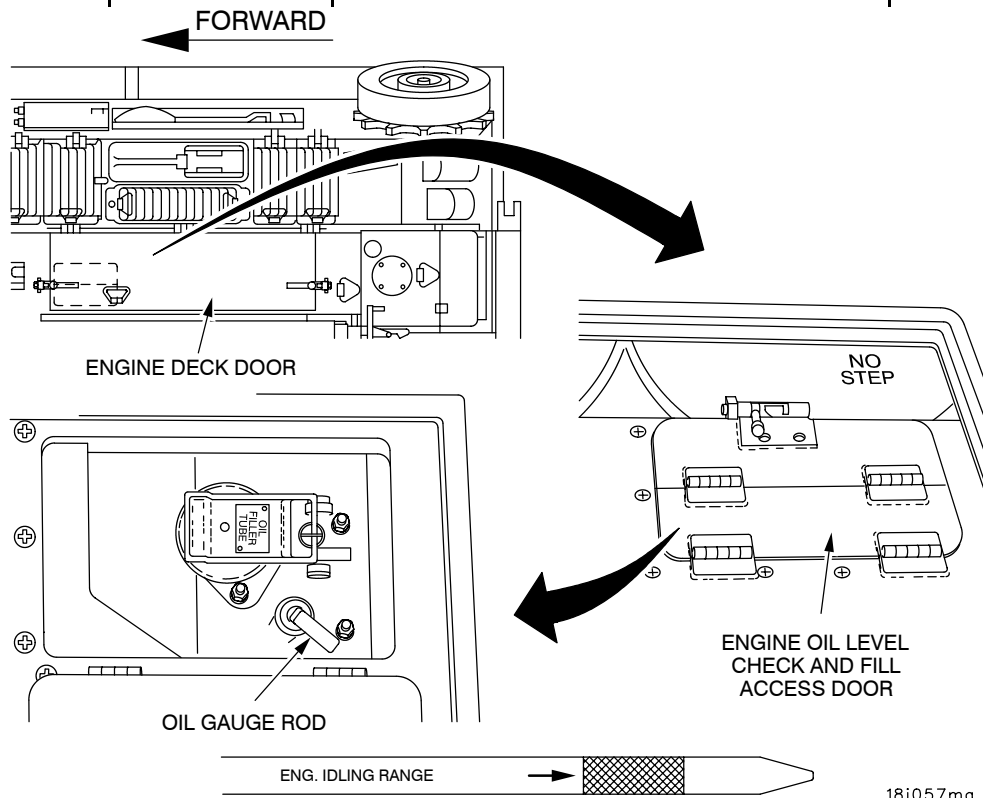

18i057mg

WARNING

Engine oil can be ignited by hot engine surfaces. To avoid engine fire, use offset funnel (item 45, Table 2, WP 0133 00) and utility jug (item 46, Table 2, WP 0133 00) to add engine oil, clean oil from around oil filler tube area with wiping rags item 45, WP 0135 00) after filling. Make sure engine oil filler tube cap is closed and engine oil fill access door is closed and latched.

PREVENTIVE MAINTENANCE CHECKS AND SERVICES INCLUDING LUBRICATION INSTRUCTIONS - CONTINUED

0105 00

TABLE 2 PREVENTIVE MAINTENANCE CHECKS AND SERVICES, DURING-CONTINUED

Item No.	Interval	LOCATION	CREWMEMBER Procedure	Not Fully Mission Capable If:
		Item to Check/Service		
6 cont	During	Engine Oil Level Check (New) - Continued	<p><u>DRIVER</u></p> <p>e. If oil level is below hash marks on ENG IDLING RANGE side of oil gauge rod, add proper amount of oil according to oil gauge rod and recheck. To add proper grade oil (Table 6, WP 0105 00):</p> <p>f. Pull up on engine oil filler tube cap handle and open engine oil filler tube.</p> <p>g. Insert offset funnel (item 45, Table 2, WP 0133 00) in oil filler tube.</p> <p>h. Add oil as required using offset funnel (item 45, Table 2, WP 0133 00) and a 2.5 gallon utility jug (item 46, Table 2, WP 0133 00).</p> <p>i. Pour oil into engine. Close oil filler tube cap and all access doors.</p>	

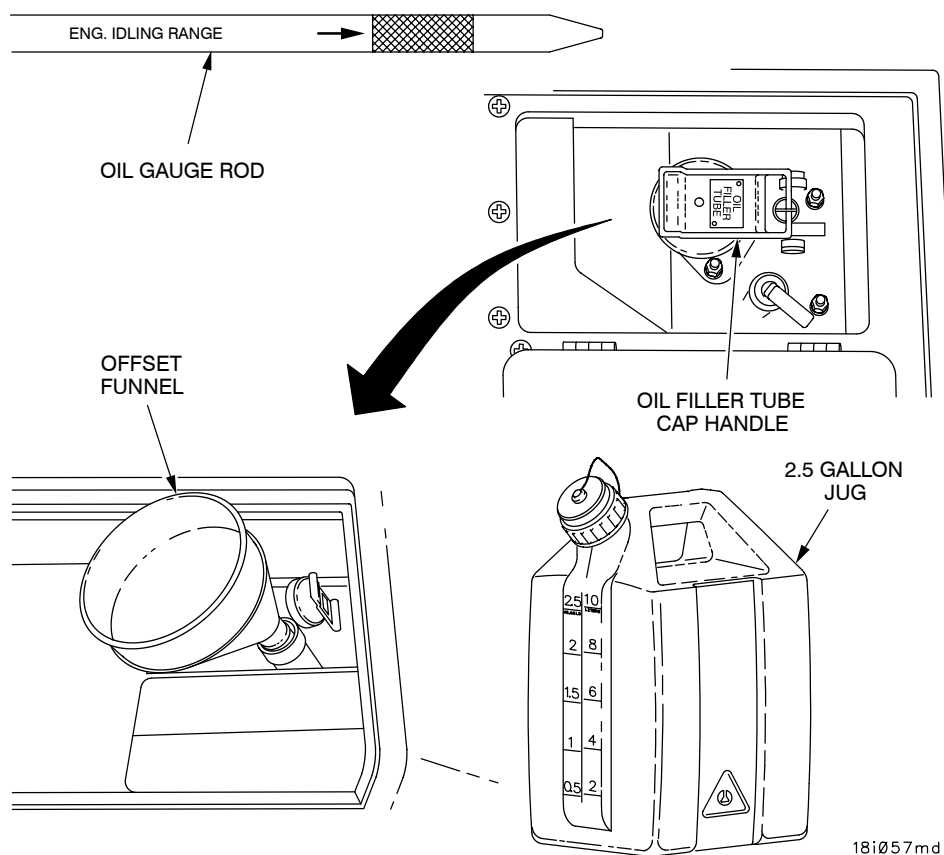

PREVENTIVE MAINTENANCE CHECKS AND SERVICES INCLUDING LUBRICATION INSTRUCTIONS - CONTINUED

0105 00

TABLE 2 PREVENTIVE MAINTENANCE CHECKS AND SERVICES, DURING-CONTINUED

Item No.	Interval	LOCATION	CREWMEMBER Procedure	Not Fully Mission Capable If:
		Item to Check/ Service		
7	During	Speedometer	<p><u>DRIVER</u></p> <p>Observe speedometer. Should operate without excessive fluctuation or unusual noises.</p> <p><u>COMMANDER</u></p>  <p>WARNING</p> <p>NOTE</p> <p>For desert or extremely dusty operation, check restriction gauge often for red mark.</p>	
8	During	Air Cleaners	<p>Observe restriction gauge (WP 0116 00). When color changes to red, clean or replace filter element. Reset restriction gauge (WP 0116 00).</p>	<p>Gauge remains in red after being reset or after air cleaners filter elements have been replaced.</p>

AIR RESTRICTION GAUGE

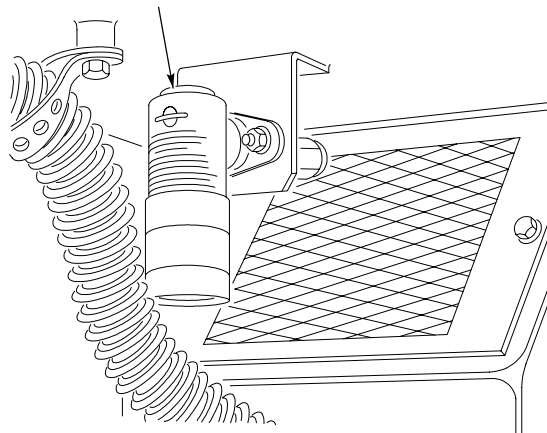

END OF TASK

**PREVENTIVE MAINTENANCE CHECKS AND SERVICES INCLUDING
LUBRICATION INSTRUCTIONS - CONTINUED**

0105 00

TABLE 3 PREVENTIVE MAINTENANCE CHECKS AND SERVICES, AFTER

INITIAL SETUP:**Tools and Special Tools**

Grease gun (item 17, Table 2, WP 0133 00)
 Funnel (item 15, Table 2, WP 0133 00)
 Adjustable wrench (item 40, Table 2, WP 0133 00)
 Crowbar (item 5, Table 2, WP 0133 00)
 Paulin (item 33, Table 1, WP 0133 00)

Materials/Parts

Hydraulic fluid (item 17, WP 0135 00)
 Grease, automotive (item 16, WP 0135 00)
 Wiping rags (item 45, WP 0135 00)

Personnel Required

Three

References

WP 0045 00
 WP 0046 00
 WP 0047 00
 WP 0127 00
 WP 0106 00

References - Continued

WP 0108 00
 WP 0109 00
 WP 0136 00
 WP 0048 00
 WP 0049 00
 WP 0037 00
 WP 0025 00
 WP 0012 00
 WP 0019 00
 WP 0036 00
 WP 0069 00
 WP 0035 00
 WP 0032 00
 WP 0133 00
 WP 0135 00
 WP 0050 00
 WP 0116 00
 WP 0131 00
 WP 0105 00
 WP 0083 00
 TM 9-1005-213-10

PREVENTIVE MAINTENANCE CHECKS AND SERVICES INCLUDING LUBRICATION INSTRUCTIONS - CONTINUED

0105 00

TABLE 3 PREVENTIVE MAINTENANCE CHECKS AND SERVICES, AFTER-CONTINUED

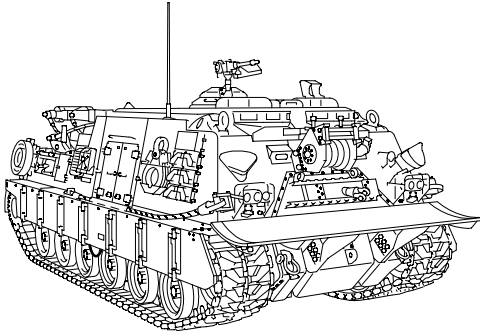
Item No.	Interval	LOCATION	CREWMEMBER Procedure	Not Fully Mission Capable If:
		Item to Check/ Service		
1	After	Spade, Hydraulic System, Boom, Main Winch, Hoist Winch, Auxiliary Winch	<p><u>DRIVER/MECHANIC</u></p>  <p>WARNING</p> <p>WARNING</p> <p>Ensure all safety pins and bolts are in place and secure prior to any lifting, towing, or winching operations.</p> <p>a. Engage main hydraulic system to determine operation of controls and pumps (WP 0045 00).</p> <p>b. Operate spade release button to determine locking function (WP 0046 00).</p>  <p>c. Raise and lower spade to determine function and to detect binding at pivot points (WP 0046 00).</p> <p>d. During operation be alert for any unusual noises or vibrations.</p> <p>e. Inspect hydraulic system for leaks, ruptures or other damage.</p> <p>WARNING</p> <p>Do not stand on engine deck or on top of vehicle when boom is being raised or lowered. Failure to comply may result in boom impacting personnel causing injury or DEATH.</p> <p>f. Check operation of main, hoist, and auxiliary winches and boom (WP 0050 00, WP 0048 00, WP 0049 00, WP 0047 00).</p>	<p>a. Hydraulic System inoperative.</p> <p>b. Spade will not lock in raise position.</p> <p>c. Will not raise or lower.</p> <p>e. Class III oil leaks</p> <p>f. Any winch or the boom inoperative.</p>

PREVENTIVE MAINTENANCE CHECKS AND SERVICES INCLUDING LUBRICATION INSTRUCTIONS - CONTINUED

0105 00

TABLE 3 PREVENTIVE MAINTENANCE CHECKS AND SERVICES, AFTER-CONTINUED

Item No.	Interval	LOCATION	CREWMEMBER Procedure	Not Fully Mission Capable If:
		Item to Check/ Service		
2	After	Fuel Shut-Off Cable	<p><u>DRIVER</u> Check for proper operation (WP 0019 00).</p>	Fuel shut-off cable is broken.
3	After	Driver's Seat	<p><u>DRIVER</u> Adjust driver's seat up and down using lever (1). Adjust seat forward and backward using lever (2). Ensure that seat moves smoothly and locks in desired position (WP 0037 00).</p>	Seat missing or will not adjust.

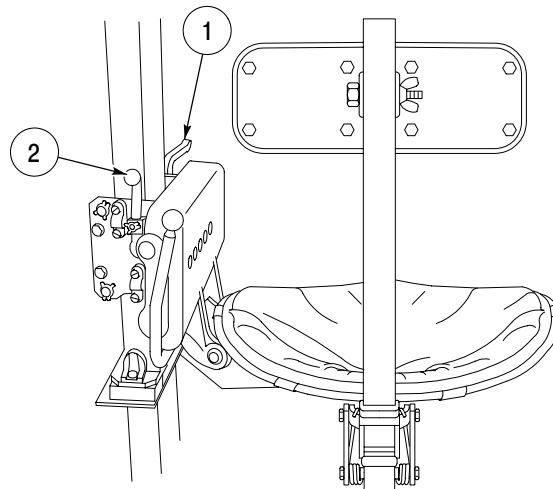

18i037m b

PREVENTIVE MAINTENANCE CHECKS AND SERVICES INCLUDING LUBRICATION INSTRUCTIONS - CONTINUED

0105 00

TABLE 3 PREVENTIVE MAINTENANCE CHECKS AND SERVICES, AFTER-CONTINUED

Item No.	Interval	LOCATION	CREWMEMBER Procedure	Not Fully Mission Capable If:
		Item to Check/ Service		
4	After	Air Cleaner Housing	<p><u>DRIVER</u></p>  <p>WARNING</p> <p>CAUTION</p> <p>Do not drop or rap filter element on a hard surface to clean. Seals may be damaged which will allow dirt to enter engine causing severe damage.</p> <p>Remove dust cover and clean out dust and debris from the cover, filter housing, and filter element (WP 0116 00). Check for damaged or unserviceable components of the air cleaner.</p>	Any holes or tears in the air filter element or dust cover seal.

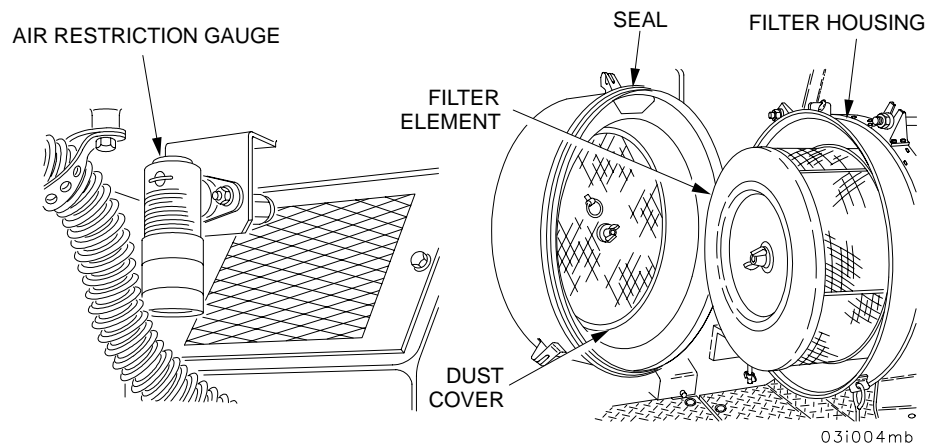

PREVENTIVE MAINTENANCE CHECKS AND SERVICES INCLUDING LUBRICATION INSTRUCTIONS - CONTINUED

0105 00

TABLE 3 PREVENTIVE MAINTENANCE CHECKS AND SERVICES, AFTER-CONTINUED

Item No.	Interval	LOCATION	CREWMEMBER Procedure	Not Fully Mission Capable If:
		Item to Check/ Service		
5	After	Smoke Grenade Launcher Controls	<p><u>COMMANDER</u></p> <p>a. Indicator light comes on when ARM/OFF switch is set to ON.</p> <p>b. Check electrical connector to launcher control for frayed wires, tears and any damage rendering the cable unserviceable.</p> <p>c. Clean smoke grenade launcher tubes (WP 0131 00).</p>	

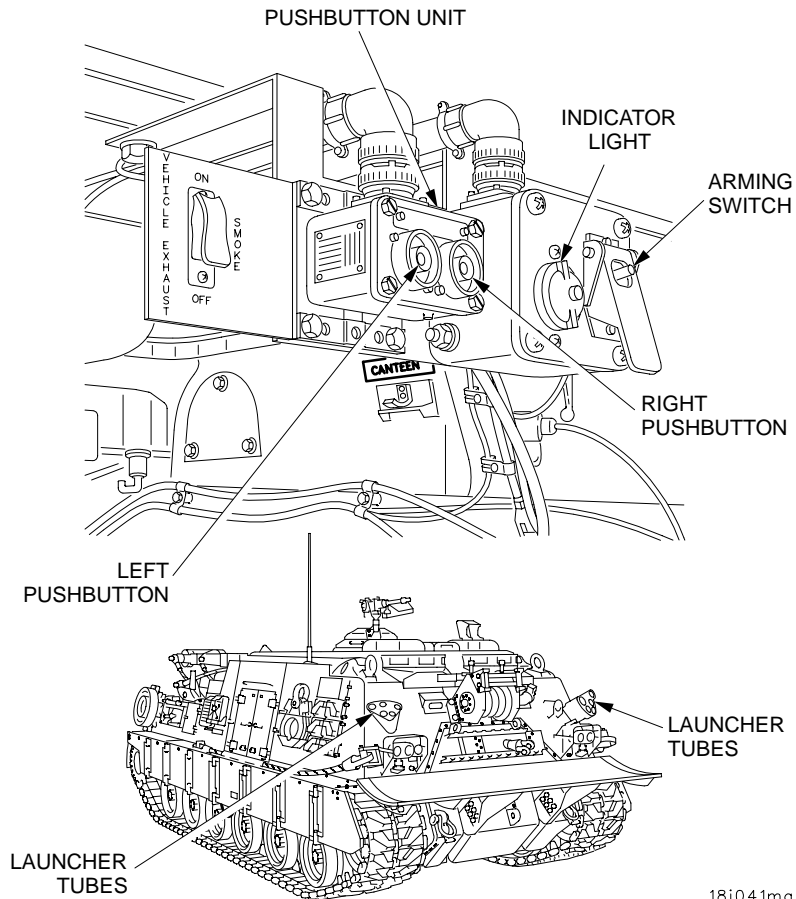

18i041ma

PREVENTIVE MAINTENANCE CHECKS AND SERVICES INCLUDING LUBRICATION INSTRUCTIONS - CONTINUED

0105 00



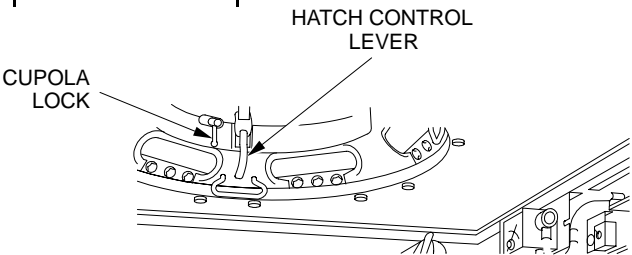
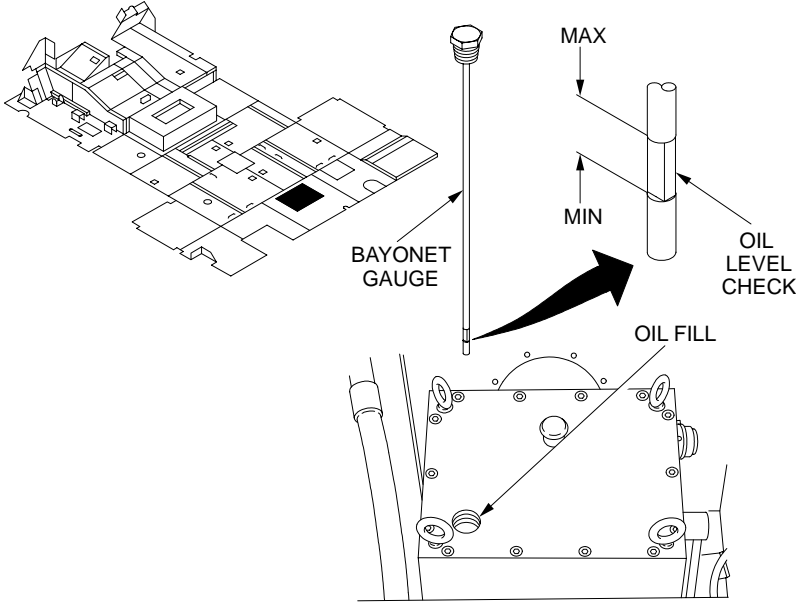

TABLE 3 PREVENTIVE MAINTENANCE CHECKS AND SERVICES, AFTER-CONTINUED

Item No.	Interval	LOCATION	CREWMEMBER Procedure	Not Fully Mission Capable If:
		Item to Check/ Service		
6	After	Cupola	<p><u>COMMANDER</u></p> <p>a. Check that cupola lock locks movement of the cupola. Release lock and test cupola for ease of movement (WP 0025 00).</p> <p>b. Check hatch operation.</p>	<p>a. Cupola moves when lock is locked. Cupola does not move easily.</p> <p>b. Hatch will not lock in open or closed position.</p>
				
7	After	Electro-Magnetic Clutch Reservoir Oil Level	<p><u>COMMANDER</u></p> <p>Park vehicle on level surface. Start main engine (WP 0012 00) and operate electromagnetic clutch for 5 minutes. Shut off engine (WP 0019 00). Open subfloor access door (WP 0036 00), remove bayonet gauge and wipe clean. Reinsert bayonet gauge. Remove bayonet gauge and verify oil level reaches the F (full) mark. If required, remove vent/fill cap and add proper grade oil (Table 6, WP 0105 00) until oil level reaches full mark on bayonet gauge. Close subfloor access door (WP 0036 00).</p>	Class III oil leaks.
				

PREVENTIVE MAINTENANCE CHECKS AND SERVICES INCLUDING LUBRICATION INSTRUCTIONS - CONTINUED

0105 00

TABLE 3 PREVENTIVE MAINTENANCE CHECKS AND SERVICES, AFTER-CONTINUED

Item No.	Interval	LOCATION	CREWMEMBER Procedure	Not Fully Mission Capable If:
		Item to Check/Service		
8	After	Hydraulic Reservoir Oil Level	<p><u>COMMANDER</u></p>     <p>Do not overfill the hydraulic reservoir with the boom down.</p> <p>Park vehicle on a level surface. Remove subfloor plate (WP 0036 00). Remove bayonet gauge, wipe clean and insert. Remove bayonet gauge and verify oil level, on the bayonet gauge, is above the DANGER mark.</p>	Class III oil leaks or oil level is at DANGER mark or below.

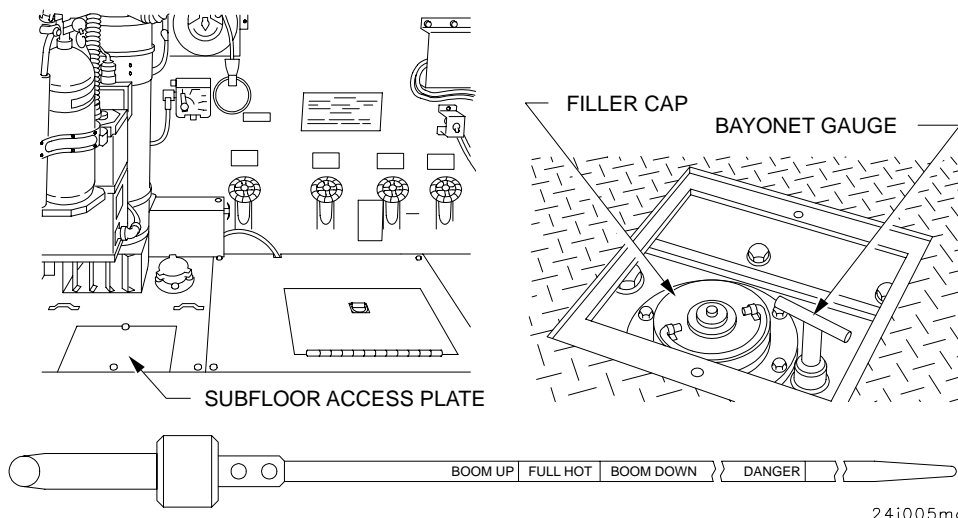

PREVENTIVE MAINTENANCE CHECKS AND SERVICES INCLUDING LUBRICATION INSTRUCTIONS - CONTINUED

0105 00

TABLE 3 PREVENTIVE MAINTENANCE CHECKS AND SERVICES, AFTER-CONTINUED

Item No.	Interval	LOCATION	CREWMEMBER Procedure	Not Fully Mission Capable If:
		Item to Check/ Service		
8 cont	After	Hydraulic Reservoir Oil Level - Continued	If required, remove filler cap and add proper grade oil (Table 6, WP 0105 00) to bring oil level above DANGER mark. Insert bayonet gauge. Start main engine (WP 0012 00) and operate hydraulic system until hydraulic oil is at operating temperature. Shut off main engine (WP 0019 00). Remove bayonet gauge and verify that oil level, on the bayonet gauge, reaches the lower FULL mark with the boom down or the upper FULL mark with the boom up. If required, remove filler cap and add oil. Install filler cap and bayonet gauge. Recheck oil level. Install subfloor plate (WP 0036 00).	Class III oil leaks.

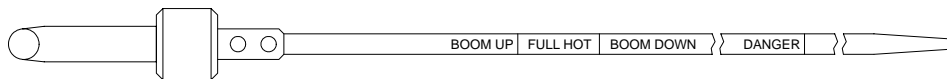
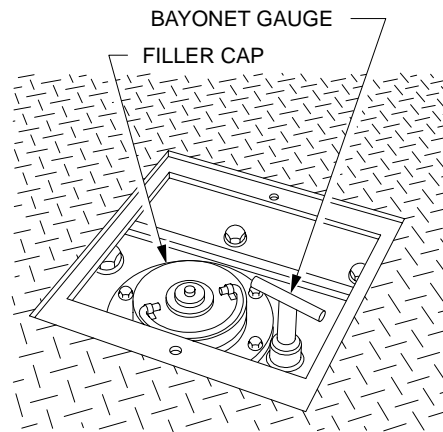
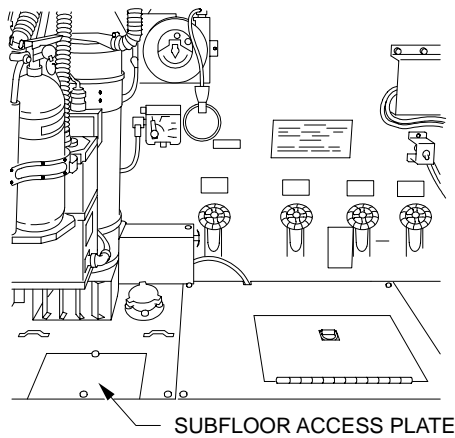

24i005m

PREVENTIVE MAINTENANCE CHECKS AND SERVICES INCLUDING LUBRICATION INSTRUCTIONS - CONTINUED

0105 00

TABLE 3 PREVENTIVE MAINTENANCE CHECKS AND SERVICES, AFTER-CONTINUED

Item No.	Interval	LOCATION	CREWMEMBER Procedure	Not Fully Mission Capable If:
		Item to Check/ Service		
9	After	Main Winch Oil Level	<p><u>COMMANDER</u></p> <p>Park vehicle on a level surface. Remove subfloor plate (WP 0036 00). Remove bayonet gauge, wipe clean, insert, remove again and verify oil level is at FULL mark.</p> <p>To add oil to the main winch, remove the bayonet gauge, install a funnel in the tube and add the proper grade of oil (Table 6, WP 0105 00). Check oil level with the bayonet gauge. Add oil until the oil level reaches the full mark. Remove the funnel and install the bayonet gauge. Install subfloor plate (WP 0036 00).</p>	Class III oil leaks

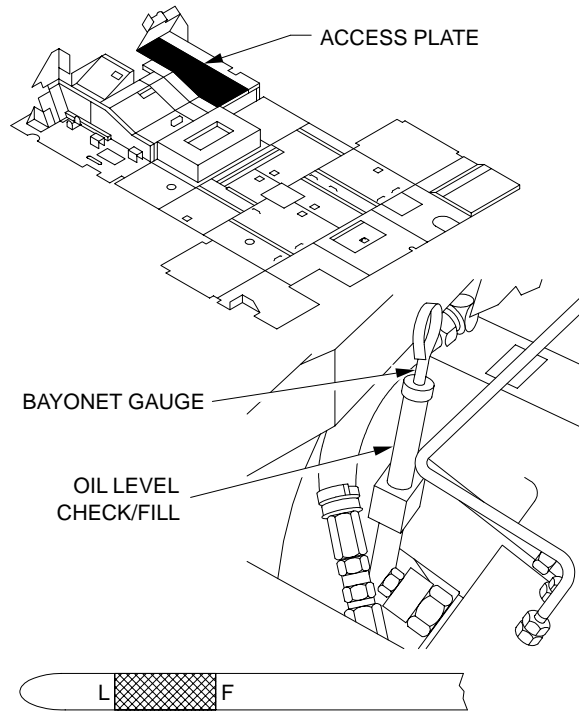

PREVENTIVE MAINTENANCE CHECKS AND SERVICES INCLUDING LUBRICATION INSTRUCTIONS - CONTINUED

0105 00

TABLE 3 PREVENTIVE MAINTENANCE CHECKS AND SERVICES, AFTER-CONTINUED

Item No.	Interval	LOCATION	CREWMEMBER Procedure	Not Fully Mission Capable If:
		Item to Check/ Service		
10	After	<u>EXTERIOR</u>	<p><u>COMMANDER</u></p> <div style="border: 2px solid black; padding: 5px; text-align: center; margin: 10px 0;">WARNING</div> <p>Check that machine gun is clear of ammo and barrel is free of obstructions to prevent injury to personnel.</p> <p style="text-align: center;">NOTE</p> <p>Refer to WP 0127 00 for removal.</p> <p>a. Disassemble, clean, and lightly lube per TM 9-1005-213-10.</p> <div style="border: 1px dashed black; padding: 5px; text-align: center; margin: 10px 0;">CAUTION</div> <p>Machine gun can fail to fire. Ensure gun is clear and safe. Check that barrel is free of obstruction to prevent damage to equipment.</p>	
		Machine Gun Caliber .50		
11	After	Machine Gun Mount	<p>Check gun mount for missing pins. Check for tightness of all fasteners and operating parts. Operate ammo box locking latch. When locked, ammo box must be sturdy and secure. (WP 0069 00).</p>	Damaged, binding, or missing parts or pins.

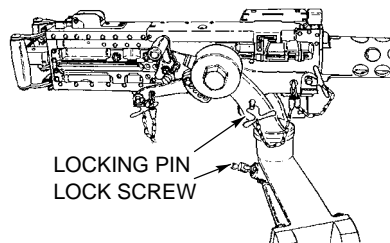

181245M

PREVENTIVE MAINTENANCE CHECKS AND SERVICES INCLUDING LUBRICATION INSTRUCTIONS - CONTINUED

0105 00



TABLE 3 PREVENTIVE MAINTENANCE CHECKS AND SERVICES, AFTER-CONTINUED

Item No.	Interval	LOCATION	CREWMEMBER Procedure	Not Fully Mission Capable If:
		Item to Check/ Service		
12	After	<p><u>EXTERIOR</u></p> <p>Snatch Block Assembly One 140-Ton, One 6.5-Ton, One 35-Ton Hook Block</p>	<p><u>DRIVER/MECHANIC</u></p> <p>a. Clean and visually inspect for presence.</p> <p>b. Inspect all snatch block housings for any cracks/defects. Inspect pulley for chips, dents and cracks. Inspect locking mechanisms for locking capabilities. Inspect hooks for cracks and straightness.</p>	<p>a. Any snatch block assembly missing.</p> <p>b. Blocks are cracked and/or do not lock. Safety screw missing from 35-ton block. Hook on block is bent. Pulleys bent.</p>
<p>The diagram illustrates the locations of three types of snatch blocks. A central cutaway view of the engine compartment is shown. Three arrows point from this central view to three separate detailed drawings of the blocks. The top-left drawing is labeled 'SNATCH BLOCK (6.5 TON)'. The bottom-left drawing is labeled 'HOOK BLOCK (35 TON)' and includes a 'SAFETY SCREW' label. The right-side drawing is labeled 'SNATCH BLOCK (140 TON)'. The diagram is identified by the number '331004m' in the bottom right corner.</p>				
13	After	<p><u>ENGINE COMPARTMENT</u></p> <p>Engine Compartment</p>	<p><u>DRIVER</u></p> <p>Raise boom (WP 0047 00) and open engine deck access doors (WP 0035 00). Check for fluid leaks.</p>	<p>Any fuel leak or Class III oil leak.</p>

PREVENTIVE MAINTENANCE CHECKS AND SERVICES INCLUDING LUBRICATION INSTRUCTIONS - CONTINUED

0105 00

TABLE 3 PREVENTIVE MAINTENANCE CHECKS AND SERVICES, AFTER-CONTINUED

Item No.	Interval	LOCATION	CREWMEMBER Procedure	Not Fully Mission Capable If:
		Item to Check/ Service		
14	After	Transmission Oil Level	<p>DRIVER</p>  <p>WARNING</p>  <p>WARNING</p>  <p>WARNING</p> <p>WARNING</p> <p>If vehicle is operated with transmission oil level <u>above</u> the FULL mark on oil gauge rod, smoke and fire may occur in vehicle exhaust system, resulting in damage to equipment or death to personnel.</p> <p>CAUTION</p> <p>If vehicle is operated with transmission oil level <u>below</u> ADD mark, reliability and durability of transmission may be reduced.</p> <p>NOTE</p> <p>The transmission assembly includes several compartments that contain oil. The transmission assembly also includes several pumps that transfer oil between these compartments.</p>	

PREVENTIVE MAINTENANCE CHECKS AND SERVICES INCLUDING LUBRICATION INSTRUCTIONS - CONTINUED

0105 00

TABLE 3 PREVENTIVE MAINTENANCE CHECKS AND SERVICES, AFTER-CONTINUED

Item No.	Interval	LOCATION	CREWMEMBER Procedure	Not Fully Mission Capable If:
		Item to Check/ Service		
14 cont	After	Transmission Oil Level - Continued	<p><u>DRIVER</u></p> <p>a. Park vehicle on a level surface with parking brake applied.</p> <p>b. Operate engine (WP 0012 00) to warm transmission oil to temperature between 180° to 200° F (82° to 93° C). To reach desired transmission oil temperature, it may be necessary to perform high range stall. To perform stall: depress and hold brake in applied position, place transmission in 3rd range and run engine at full throttle for no longer than 30 seconds. Return engine speed to idle. If required, repeat procedure after 60 seconds of idling to attain the proper oil temperature.</p> <p>c. Shut down engine (WP 0019 00).</p> <div style="text-align: center;"> <p>CAUTION</p> </div> <p>To verify that proper transmission oil level is present, it is very important that transmission oil level is at correct temperature <u>and</u> that correct amount of time, 3 to 5 minutes, has passed before reading oil gauge rod. Failure to comply may result in an inaccurate oil level reading. If vehicle is operated with transmission oil level <u>below</u> ADD mark, reliability and durability of transmission assembly may be reduced.</p>	Oil level below ADD mark.

PREVENTIVE MAINTENANCE CHECKS AND SERVICES INCLUDING LUBRICATION INSTRUCTIONS - CONTINUED

0105 00

TABLE 3 PREVENTIVE MAINTENANCE CHECKS AND SERVICES, AFTER-CONTINUED

Item No.	Interval	LOCATION	CREWMEMBER Procedure	Not Fully Mission Capable If:
		Item to Check/ Service		
14 cont	After	Transmission Oil Level - Continued	<p>DRIVER</p> <p>d. Open left side engine deck grille and exhaust deflector (WP 0032 00). Open transmission oil filler tube access doors.</p> <p>e. Remove transmission oil gauge rod from oil filler tube, clean oil gauge rod.</p> <p>f. Insert oil gauge rod into transmission filler tube. Remove oil gauge rod and verify that oil level is between ADD and FULL marks.</p> <p style="text-align: center;">NOTE</p> <p>Excess oil may be removed from transmission using the AOAP valve.</p> <p>g. If indicated oil level is <u>above</u> FULL mark on the oil gauge rod, start engine (WP 0012 00) and remove excess oil from transmission.</p>	Oil level below ADD mark.

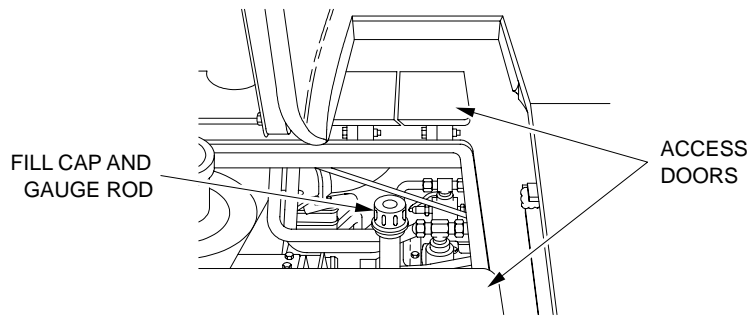



071093m

PREVENTIVE MAINTENANCE CHECKS AND SERVICES INCLUDING LUBRICATION INSTRUCTIONS - CONTINUED

0105 00

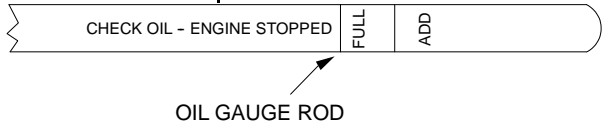
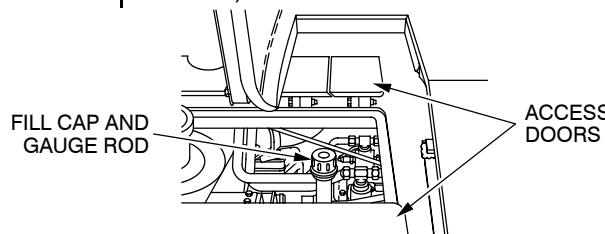
TABLE 3 PREVENTIVE MAINTENANCE CHECKS AND SERVICES, AFTER-CONTINUED

Item No.	Interval	LOCATION	CREWMEMBER Procedure	Not Fully Mission Capable If:
		Item to Check/ Service		
14 cont	After	Transmission Oil Level - Continued	<p><u>DRIVER</u></p> <p>NOTE</p> <p>1/2 inch (12.7 mm) on oil gauge rod equals about one gallon of oil.</p> <p>h. If indicated oil level is <u>below</u> ADD mark on oil gauge rod, add enough proper grade oil (Table 6, WP 0105 00) to transmission to bring oil level between ADD and FULL marks.</p> <p>i. Restart engine (WP 0012 00) and warm transmission oil to 180° to 200° F (82° to 93° C).</p> <p>j. Shut down engine (WP 0019 00).</p>	Oil level below ADD mark.
 <p>OIL GAUGE ROD</p> <p>07i094m</p>				
<p>CAUTION</p> <p>To verify that proper transmission oil level is present, it is very important that transmission oil level is at correct temperature <u>and</u> that correct amount of time, 3 to 5 minutes, has passed before reading oil gauge rod. Failure to comply may result in an inaccurate oil level reading. If vehicle is operated with transmission oil level <u>below</u> ADD mark, reliability and durability of transmission assembly may be reduced.</p> <p>k. Check transmission level again to verify that oil levels are between ADD and FULL marks.</p> <p>l. Re-install oil gauge rod into transmission oil filler tube. Close left side engine deck exhaust grille and exhaust deflector WP 0032 00).</p>				
 <p>FILL CAP AND GAUGE ROD</p> <p>ACCESS DOORS</p>				
 <p>07i093ma</p>				

PREVENTIVE MAINTENANCE CHECKS AND SERVICES INCLUDING LUBRICATION INSTRUCTIONS - CONTINUED

0105 00

TABLE 3 PREVENTIVE MAINTENANCE CHECKS AND SERVICES, AFTER-CONTINUED

Item No.	Interval	LOCATION	CREWMEMBER Procedure	Not Fully Mission Capable If:
		Item to Check/ Service		
15	After	<u>Exterior</u> Tow Lugs (Rear and Front)	<u>DRIVER/MECHANIC</u> Visually inspect for presence and condition.	Tow lugs missing or broken.
18i060m				
16	After	Tow Chain (rear)	<u>DRIVER/MECHANIC</u> Visually inspect for presence. Check for cracked/broken links or attaching eyes. Check for loose or missing mounting hardware.	Tow chain missing. Tow chain has cracked or broken links or attaching eyes.
17	After	Tow Pintle	<u>DRIVER</u> Visually inspect for presence, condition, and cracks. Move tow pintle lock and pintle hook by hand. REPLACE TOW PINTLE IF PRY BAR IS NEEDED TO OPEN JAW AFTER TOWING MISSION AND LUBING.	Tow pintle missing, broken, cracked; or pintle lock and hook will not operate by hand.

PREVENTIVE MAINTENANCE CHECKS AND SERVICES INCLUDING LUBRICATION INSTRUCTIONS - CONTINUED

0105 00

TABLE 3 PREVENTIVE MAINTENANCE CHECKS AND SERVICES, AFTER-CONTINUED

Item No.	Interval	LOCATION	CREWMEMBER Procedure	Not Fully Mission Capable If:
		Item to Check/ Service		
18	After	Final Drive, Right and Left Side	<p><u>DRIVER</u></p> <p>a. Check for Class III oil leakage between final drive and bottom of sprocket.</p> <p>b. Check for sheared mounting bolts.</p> <p>c. Check drive sprocket (reversible) for missing mounting bolts or broken sprocket teeth. If driving side of sprocket is worn to wear limits, notify unit maintenance.</p> <p>d. Check final drive hubs for overheating.</p> <p>NOTE</p> <p>Have unit maintenance confirm serviceability of drive sprocket before exchange or reversal of sprocket.</p>	<p>a. Class III leak.</p> <p>b. More than two final drive hub bolts sheared off on any one final drive.</p> <p>c. Any portion of wear limit indicator no longer visible on driving side of sprocket tooth.</p>

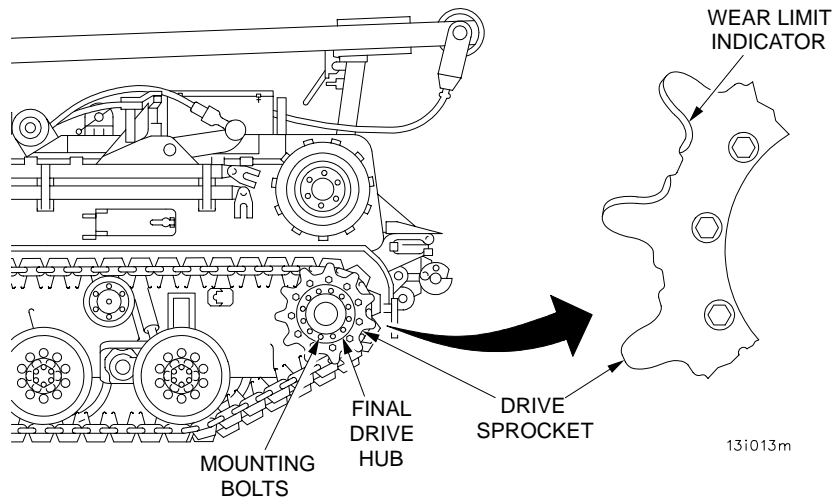

NOTE: SKIRTS REMOVED FOR CLARITY

PREVENTIVE MAINTENANCE CHECKS AND SERVICES INCLUDING LUBRICATION INSTRUCTIONS - CONTINUED

0105 00

TABLE 3 PREVENTIVE MAINTENANCE CHECKS AND SERVICES, AFTER-CONTINUED

Item No.	Interval	LOCATION	CREWMEMBER Procedure	Not Fully Mission Capable If:
		Item to Check/ Service		
19	After	Tow Bars (2 each), Tow Cables (2 each), Back and Side Mounted	<p><u>DRIVER/MECHANIC</u></p> <p>a. Visually inspect for presence.</p> <p>b. Inspect tow bar legs for bends and cracks. Inspect lunette for cracks and bends. Inspect for tow bar pins, clevises, and locking pins.</p> <p>c. Inspect tow cables for kinks, broken/frayed wires. Inspect eyelets for cracks.</p>	<p>a. Both tow bars missing.</p> <p>b. Any bends, cracks, missing pins/locking pins. Lunette bent or cracked.</p> <p>c. Missing, kinks, bends, or broken/frayed wires. Eyelet cracked.</p>

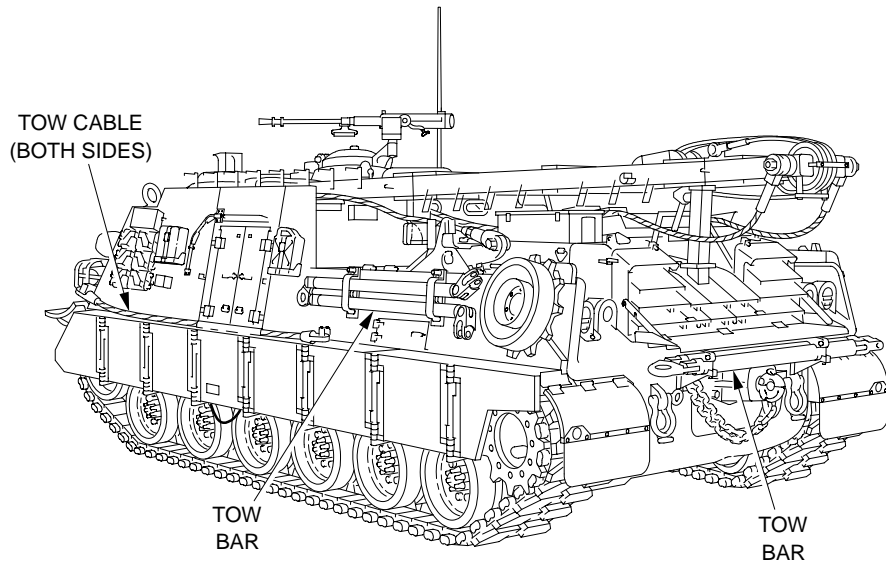

18i224m

PREVENTIVE MAINTENANCE CHECKS AND SERVICES INCLUDING LUBRICATION INSTRUCTIONS - CONTINUED

0105 00

TABLE 3 PREVENTIVE MAINTENANCE CHECKS AND SERVICES, AFTER-CONTINUED

Item No.	Interval	LOCATION	CREWMEMBER	Not Fully Mission Capable If:
		Item to Check/Service	Procedure	
20	After	Temperatures of Roadwheel, Idler and Support Roller Hubs and Shock Absorbers	<p><u>DRIVER/MECHANIC</u></p> <div style="text-align: center;">  <div style="border: 1px solid black; padding: 2px; display: inline-block; margin: 0 10px;">WARNING</div> <div style="border: 1px solid black; padding: 2px; display: inline-block; margin: 10px auto 0 auto;">WARNING</div> </div> <p>Do not remove all four hinge pins from the same skirt. Skirt may fall, causing serious injury.</p> <p style="text-align: center;">NOTE</p> <p>Open skirts #1, #3, #5 and #7 on left and right sides.</p> <p>As time permits during halts and immediately after vehicle operation, open skirts (WP 0106 00). Feel these components cautiously for noticeable variation in temperature between like components. An overheated hub indicates maladjustments, inadequate lubrication of bearings. If shock absorbers are defective, they will be colder than the hull.</p>	Any hub found to be overheated.

PREVENTIVE MAINTENANCE CHECKS AND SERVICES INCLUDING LUBRICATION INSTRUCTIONS - CONTINUED

0105 00

TABLE 3 PREVENTIVE MAINTENANCE CHECKS AND SERVICES, AFTER-CONTINUED

Item No.	Interval	LOCATION	CREWMEMBER Procedure	Not Fully Mission Capable If:
		Item to Check/ Service		
21	After	Track Support Rollers, Hubs Right and Left Side and Shock Absorbers	<p><u>DRIVER</u></p> <p>a. Check for missing or loose track support rollers.</p> <p>b. Check rollers for separation of rubber from metal and chunking.</p>  <div style="border: 1px solid black; padding: 2px; display: inline-block; margin-left: 10px;">WARNING</div> <p>c. Cautiously grasp shock absorber and shake. Check for movement which indicates worn mounting bushings.</p>	<p>a. Any track support roller missing or loose.</p> <p>b. Any support roller has elongated mounting holes. Rubber separation and/or chunking equals half the original contact area around the entire roller.</p>

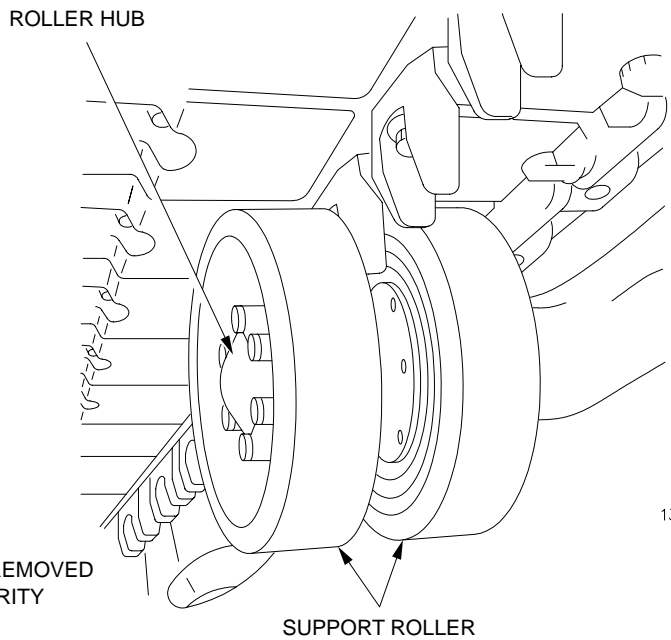

NOTE:
SKIRTS REMOVED
FOR CLARITY

13i014m

PREVENTIVE MAINTENANCE CHECKS AND SERVICES INCLUDING LUBRICATION INSTRUCTIONS - CONTINUED

0105 00

TABLE 3 PREVENTIVE MAINTENANCE CHECKS AND SERVICES, AFTER-CONTINUED

Item No.	Interval	LOCATION	CREWMEMBER Procedure	Not Fully Mission Capable If:
		Item to Check/ Service		
22	After	Roadwheels and Hubs Compensating Idler Wheels And Hubs Right and Left Side	<p><u>DRIVER</u></p> <p>a. Check for bent, broken or missing roadwheel, or compensating idler wheel.</p> <p>b. Check for any loose or missing mounting bolts or nuts.</p> <p>c. Check roadwheels and compensating idler wheels for chunking or separation.</p> <p>d. Inspect inner and outer roadwheel and compensating idler wheel hubs for leaks.</p> <p>NOTE Splattered grease indicates defective seal.</p>	<p>a. Two roadwheels or idler wheels on same arm, either side, cracked, bent, or missing.</p> <p>b. Two or more mounting nuts missing on same wheel hub.</p> <p>c. Separation of 1 in. of rubber contact from metal surface around 75% of roadwheel or compensating idler wheels and/or chunking that exposes metal extending 3 to 4 in. on wheel surface exists.</p>

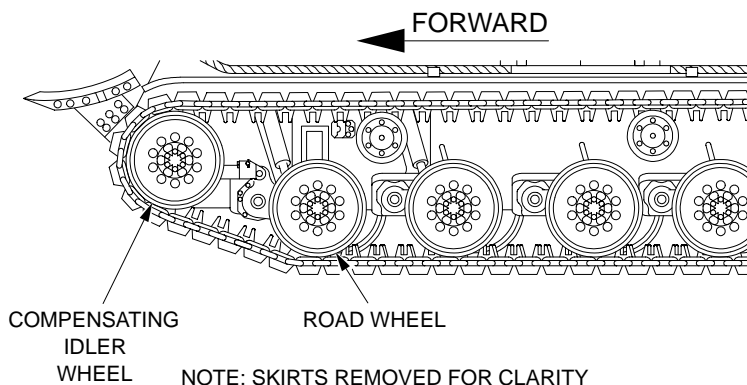

18i062m

PREVENTIVE MAINTENANCE CHECKS AND SERVICES INCLUDING LUBRICATION INSTRUCTIONS - CONTINUED

0105 00

TABLE 3 PREVENTIVE MAINTENANCE CHECKS AND SERVICES, AFTER-CONTINUED

Item No.	Interval	LOCATION	CREWMEMBER Procedure	Not Fully Mission Capable If:
		Item to Check/ Service		
23	After	Track Shoes, Right and Left Side	<p><u>CREWMEMBER</u></p> <p>a. Check for excessive wear, worn, missing or cracked end connectors.</p> <p>(1) End connector wear thickness 1/8 inch.</p> <p>b. Check end connectors for missing, loose or improperly sealed wedges or wedge bolts. If end connectors or center guides are found to be loose at halts, tighten them. Also, notify unit maintenance ASAP for inspection and application of proper torque.</p> <p>c. Check for missing, bent, cracked or broken track pins.</p>	<p>One or more end connectors missing or cracked.</p> <p>Worn to less than 1/8 inch thickness.</p> <p>One or more wedges missing or improperly sealed.</p> <p>One or more missing, cracked or broken track pins.</p>

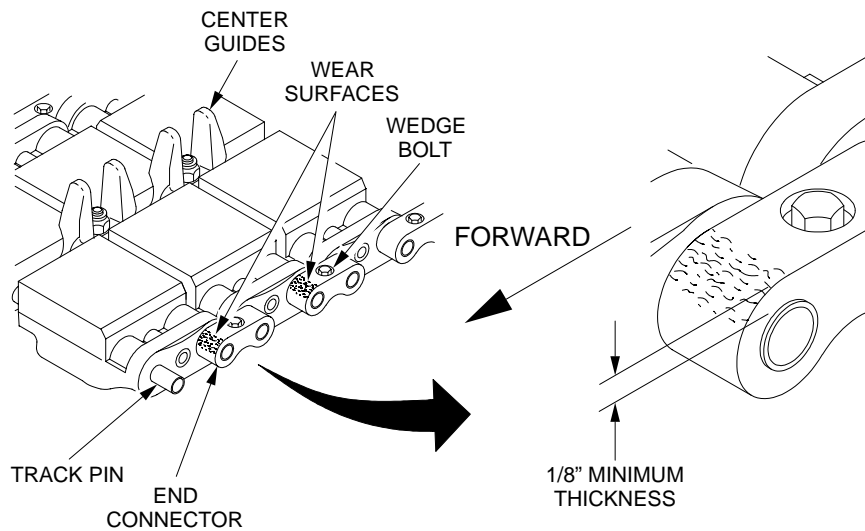

131045m

PREVENTIVE MAINTENANCE CHECKS AND SERVICES INCLUDING LUBRICATION INSTRUCTIONS - CONTINUED

0105 00

TABLE 3 PREVENTIVE MAINTENANCE CHECKS AND SERVICES, AFTER-CONTINUED

Item No.	Interval	LOCATION	CREWMEMBER Procedure	Not Fully Mission Capable If:
		Item to Check/ Service		
23 Cont	After	Track Shoes, Right and Left Side - Continued	<p><u>CREWMEMBER</u></p> <p>d. Check for exposed binocular tubes on roadwheel path and/or grouser surface.</p> <p>e. Check cooling tubes for damage or separation above cooling tube.</p>	<p>If binocular tube is exposed or damaged on the roadwheel path and/or grouser surface. Grouser height less than 1/2 inch.</p> <p>If separation of rubber is 2 inches or more above cooling tube, or if a cooling tube has moved in or out 1/4 inch or more, or damaged cooling tube.</p>

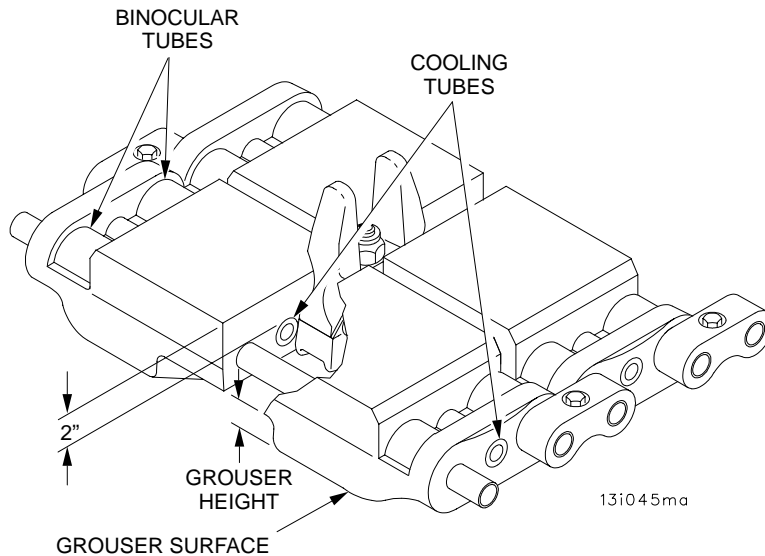

PREVENTIVE MAINTENANCE CHECKS AND SERVICES INCLUDING LUBRICATION INSTRUCTIONS - CONTINUED

0105 00

TABLE 3 PREVENTIVE MAINTENANCE CHECKS AND SERVICES, AFTER-CONTINUED

Item No.	Interval	LOCATION	CREWMEMBER Procedure	Not Fully Mission Capable If:
		Item to Check/ Service		
23 - Cont	After	Track Shoes, Right and Left Side - Continued	<p><u>CREWMEMBER</u></p> <p>f. Inspect for dead (broken) track shoes. A dead track shoe appears to be out-of-line.</p> <p style="text-align: center;">NOTE</p> <p>If end connectors or center guides are found to be loose at halts, tighten them.</p> <p>g. Check for cracked or broken end plates.</p> <p>h. Check end plates for cracks, breaks or wear to 1/4 inch or less.</p>	<p>One or more dead (broken) track shoes.</p> <p>One or more end plates cracked or broken.</p> <p>One or more end plates cracked, broken or worn to less than 1/4 inch.</p>

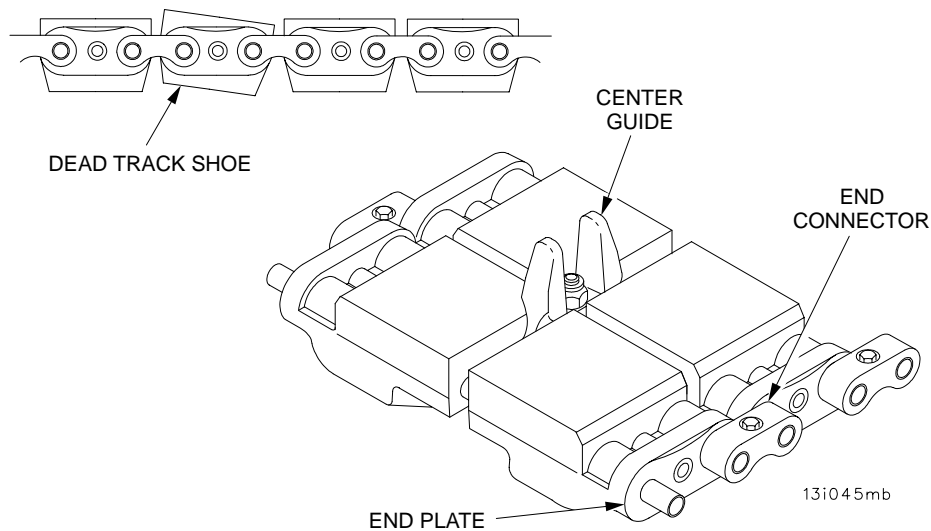

PREVENTIVE MAINTENANCE CHECKS AND SERVICES INCLUDING LUBRICATION INSTRUCTIONS - CONTINUED

0105 00

TABLE 3 PREVENTIVE MAINTENANCE CHECKS AND SERVICES, AFTER-CONTINUED

Item No.	Interval	LOCATION	CREWMEMBER Procedure	Not Fully Mission Capable If:
		Item to Check/ Service		
24	After	Torsion Bars For Road- wheels Left and Right Side	<p><u>DRIVER</u></p> <p>a. At roadwheel arm positions 1 and 6, look for tilt of vehicle or lifting of roadwheel and track off ground. Tilting of vehicle or lifted roadwheel/track may be an indicator of a broken torsion bar.</p> <p>b. To test torsion bars at roadwheel arm positions 2 thru 5, use tanker's bar to pry up on roadwheels. If roadwheel cannot be lifted, torsion bar is good. If roadwheel can be lifted, the torsion bar may be broken.</p>	<p>a. Torsion bars at roadwheels 1 and/or 6 broken or missing.</p> <p>b. Any two torsion bars in a row are broken or missing at roadwheels 2-5.</p>

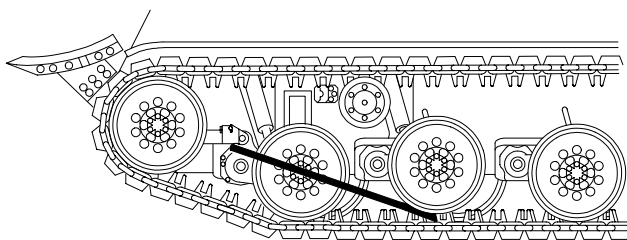

BAD TORSION BAR 2-5

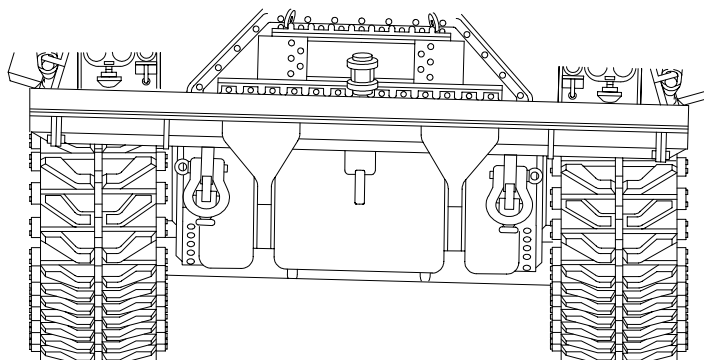

VEHICLE
TILTED
TO THIS
SIDE

BAD TORSION BAR 1 OR 6

NOTE: SKIRTS REMOVED FOR CLARITY

13i016m

PREVENTIVE MAINTENANCE CHECKS AND SERVICES INCLUDING LUBRICATION INSTRUCTIONS - CONTINUED

0105 00

TABLE 3 PREVENTIVE MAINTENANCE CHECKS AND SERVICES, AFTER-CONTINUED

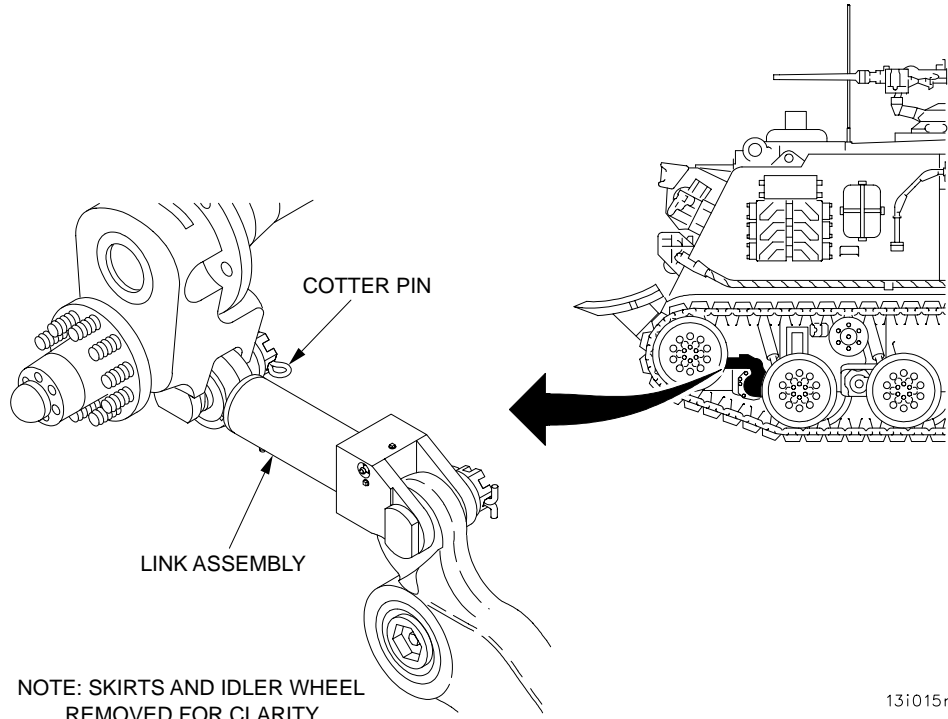
Item No.	Interval	LOCATION	CREWMEMBER Procedure	Not Fully Mission Capable If:
		Item to Check/ Service		
25	After	Track Adjusting Links, Right and Left Side	<p><u>DRIVER</u></p> <p>a. Check that link assembly is not missing or broken.</p> <p>b. Check that cotter pin is not missing or broken.</p> <p>c. Check connector pin and retainer bolt.</p> <p>d. Close skirts (WP 0106 00).</p>	<p>a. Link assembly broken, missing or damaged.</p> <p>b. Connector pin broken, missing or nut missing.</p>
 <p>NOTE: SKIRTS AND IDLER WHEEL REMOVED FOR CLARITY</p> <p>13i015m</p>				
26	After	Track Tension, Right and Left Side	<p><u>CREW</u></p> <p>NOTE Adjust track tension after all other track inspection faults have been corrected.</p> <p>a. Move vehicle forward on hard level surface and coast to stop without using brakes or steering.</p> <p>b. Open skirts #1 thru #5 (WP 0106 00).</p> <p>c. Check and adjust track tension (WP 0108 00 or WP 0109 00).</p> <p>d. Close skirts #1 thru #8 (WP 0106 00).</p>	

PREVENTIVE MAINTENANCE CHECKS AND SERVICES INCLUDING LUBRICATION INSTRUCTIONS - CONTINUED

0105 00

TABLE 3 PREVENTIVE MAINTENANCE CHECKS AND SERVICES, AFTER-CONTINUED

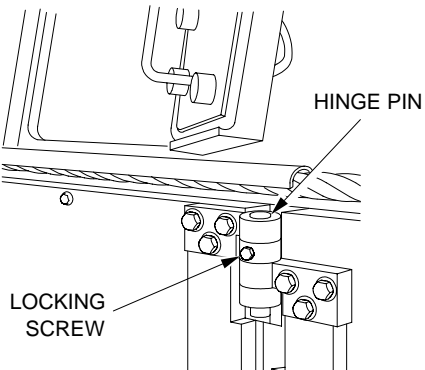
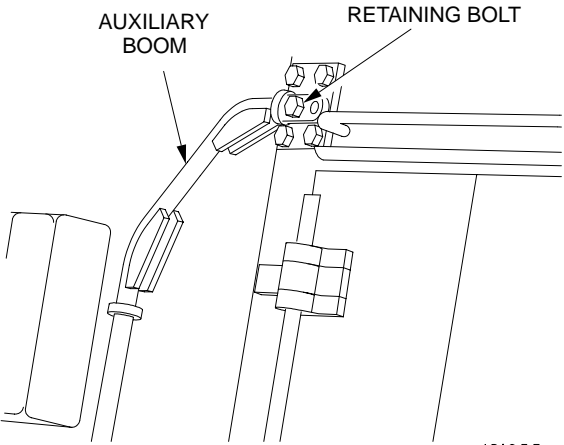
Item No.	Interval	LOCATION	CREWMEMBER Procedure	Not Fully Mission Capable If:
		Item to Check/ Service		
27	After	Side Armor Skirt Panel Hinge Pins and Locking Screws.	<p><u>DRIVER</u></p> <p>Check that all side armor skirt hinge pins and locking screws are present.</p> 	Any hinge pin or locking screw missing or broken.
28	After	Auxiliary Boom and Retaining Bolt	<p><u>DRIVER</u></p> <p>Check that auxiliary boom and retaining bolt are present and undamaged.</p> 	

PREVENTIVE MAINTENANCE CHECKS AND SERVICES INCLUDING LUBRICATION INSTRUCTIONS - CONTINUED

0105 00

TABLE 3 PREVENTIVE MAINTENANCE CHECKS AND SERVICES, AFTER-CONTINUED

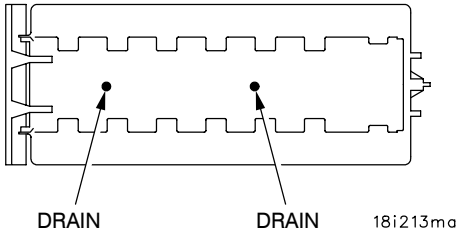
Item No.	Interval	LOCATION	CREWMEMBER Procedure	Not Fully Mission Capable If:
		Item to Check/ Service		
29	After	Storage Boxes and Stowed Equipment	<u>DRIVER</u> Check condition of boxes and equipment (listed in Tables 3 and 4, WP 0136 00) to see if they are secure, serviceable and clean.	
30	After	Hull Drains	Open both vehicle hull drains. Allow vehicle hull to drain (WP 0083 00).	
<p>BOTTOM VIEW OF VEHICLE</p> <p>← FORWARD</p> 				
31	After	Hull Drains and Access Plates	<p style="text-align: center;">CAUTION</p> <p>If vehicle is being parked for an extended period of time (two weeks or longer) both hull drains must be left open.</p> <p>All five hull access plates must be removed.</p> <p>Engine deck area must be covered.</p> <p>Failure to comply could result in vehicle damage due to excessive water build-up in vehicle engine compartment.</p>	

PREVENTIVE MAINTENANCE CHECKS AND SERVICES INCLUDING LUBRICATION INSTRUCTIONS - CONTINUED

0105 00

TABLE 3 PREVENTIVE MAINTENANCE CHECKS AND SERVICES, AFTER-CONTINUED

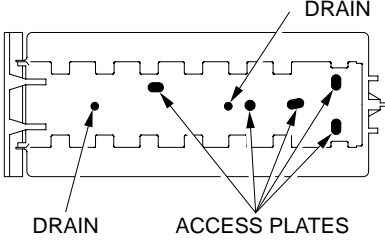
Item No.	Interval	LOCATION	CREWMEMBER Procedure	Not Fully Mission Capable If:
		Item to Check/ Service		
31 Cont	After	Hull Drains and Access Plates	<p>a. Open both vehicle hull drains, and make sure drains are clear and free of debris.</p> <p>b. Make sure all five hull access plates are removed (including brake adjustment access covers). If access plates are removed, notify Unit Maintenance.</p> <p>c. Cover engine deck with nylon paulin (item 33, Table 1, WP 0133 00).</p> <p style="text-align: center;">BOTTOM VIEW OF VEHICLE FORWARD ←</p>  <p style="text-align: right;">18i213m</p>	

PREVENTIVE MAINTENANCE CHECKS AND SERVICES INCLUDING LUBRICATION INSTRUCTIONS - CONTINUED

0105 00

TABLE 4 PREVENTIVE MAINTENANCE CHECKS AND SERVICES, WEEKLY

INITIAL SETUP:

Tools and Special Tools

- Adjustable wrench (item 40, Table 2, WP 0133 00)
- Gloves (item 16, Table 2, WP 0133 00)

Materials/Parts

- Wiping rags (item 45, WP 0135 00)
- Lubricating oil (item 25, WP 0135 00)
- Grease, automotive (item 16, WP 0135 00)
- Lens paper (item 35, WP 0135 00)

Personnel Required

Three

References

- WP 0032 00 WP 0133 00
- WP 0035 00 WP 0135 00
- WP 0026 00 WP 0017 00
- WP 0024 00 WP 0030 00
- WP 0023 00 WP 0117 00
- WP 0059 00 WP 0136 00
- WP 0056 00 WP 0021 00
- WP 0068 00 WP 0022 00
- WP 0119 00

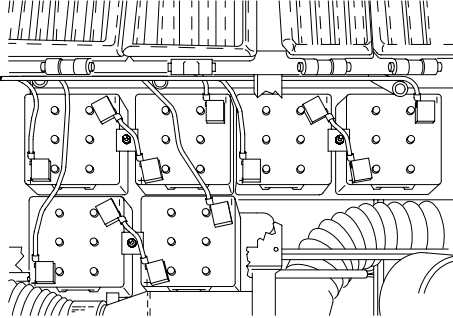
Item No.	Interval	LOCATION	CREWMEMBER Procedure	Not Fully Mission Capable If:
		Item to Check/Service		
1	Weekly	Batteries	<p>DRIVER</p>  <p>a. Open battery compartment access doors.</p> <p>b. Check electrolyte level. Electrolyte level should be to the ledge in battery filler opening (vent). If low or boiling, notify unit maintenance.</p> <p>c. Check that connections are tight and not corroded. If corroded or loose, notify unit maintenance. Caps should be clean and screwed on tightly.</p> <p>d. Check for cracked batteries. If cracked, notify unit maintenance.</p>  <p style="text-align: right; font-size: small;">061035mb</p>	<p>a. Battery is missing.</p> <p>b. Electrolyte level is low or boiling.</p> <p>c. Any loose cables or connections.</p> <p>d. Battery is cracked.</p> <p>e. Batteries will not start vehicle.</p>

PREVENTIVE MAINTENANCE CHECKS AND SERVICES INCLUDING LUBRICATION INSTRUCTIONS - CONTINUED

0105 00

TABLE 4 PREVENTIVE MAINTENANCE CHECKS AND SERVICES, WEEKLY-CONTINUED

Item No.	Interval	LOCATION	CREWMEMBER Procedure	Not Fully Mission Capable If:
		Item to Check/ Service		
2	Weekly	Service Brake Adjustment and Rear Grille Doors	<p><u>DRIVER</u></p> <p>a. Fully apply and lock vehicle service brakes (WP 0017 00).</p> <p>b. Open left and right side rear grille doors (1) (WP 0032 00).</p> <p>c. Open left and right side transmission access doors (2).</p> <p>NOTE</p> <p>Brake pedal must be fully applied to ensure accurate brake adjustment reading.</p> <p>d. Ensure Brake Adjustment Indicator (3) (painted on brake linkage) is aligned with the Brake Adjustment Indicator Rod (4) (attached to transmission guide rails). Repeat on other side.</p> <p>e. Close left and right side transmission access doors (2).</p> <p>f. Close left and right side rear grille doors (1). Make sure grille doors are secure (WP 0032 00).</p>	<p>a. Brake Adjustment Indicators out of alignment. Contact unit maintenance.</p> <p>b. Grille doors are missing or cannot be closed and secured.</p>

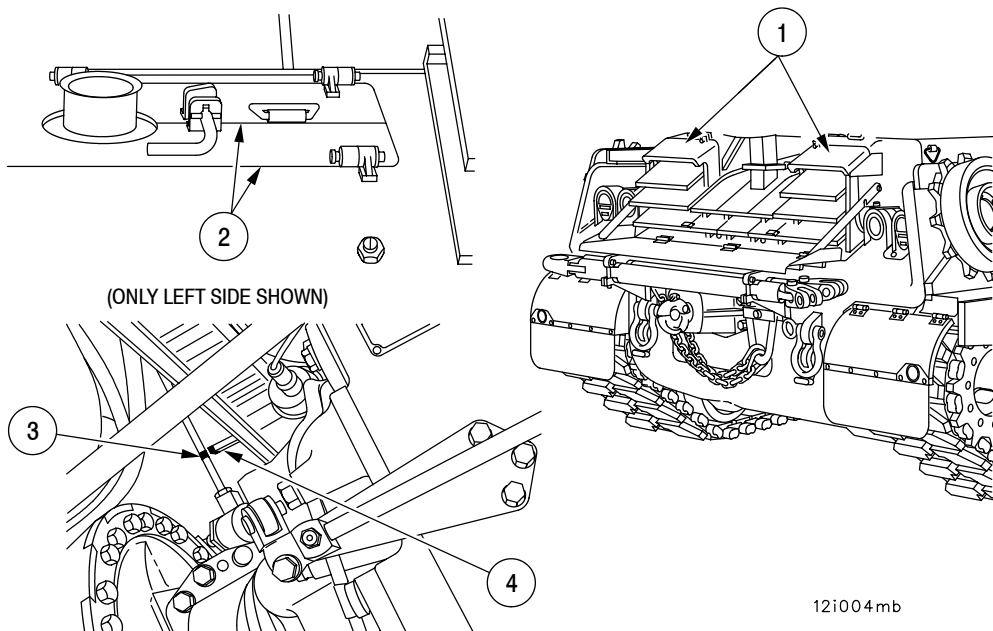

PREVENTIVE MAINTENANCE CHECKS AND SERVICES INCLUDING LUBRICATION INSTRUCTIONS - CONTINUED

0105 00

TABLE 4 PREVENTIVE MAINTENANCE CHECKS AND SERVICES, WEEKLY-CONTINUED

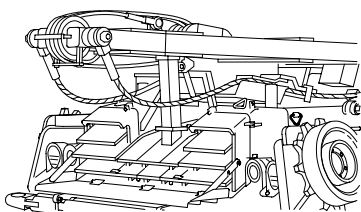
Item No.	Interval	LOCATION	CREWMEMBER Procedure	Not Fully Mission Capable If:
		Item to Check/ Service		
3	Weekly	Boom	<p><u>DRIVER</u> Visually inspect boom travel lock for operation and condition. Visually inspect boom, rollers, cylinders, boom levers, and pulleys for condition and damage.</p>  <p style="text-align: right; margin-right: 50px;">18i026ma</p>	Boom travel lock is damaged or missing, which would allow boom to bounce up and down while vehicle is moving; broken or bent pulleys.
4	Weekly	Auxiliary Power Unit	<p><u>DRIVER</u> Park vehicle on a level surface. Open APU compartment door until secured by hold open latch (WP 0030 00). Check and fill crankcase and check and fill chaincase in accordance with Table 6, WP 0105 00.</p>	

PREVENTIVE MAINTENANCE CHECKS AND SERVICES INCLUDING LUBRICATION INSTRUCTIONS - CONTINUED

0105 00

TABLE 4 PREVENTIVE MAINTENANCE CHECKS AND SERVICES, WEEKLY-CONTINUED

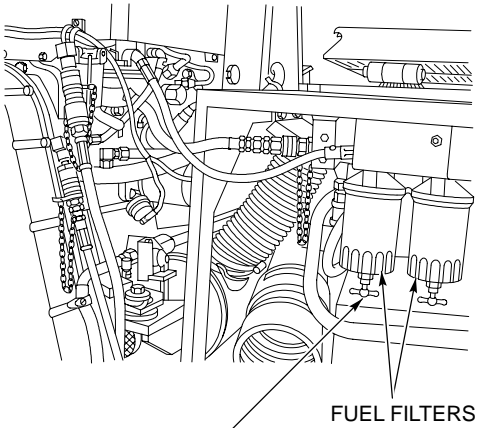
Item No.	Interval	LOCATION	CREWMEMBER Procedure	Not Fully Mission Capable If:
		Item to Check/ Service		
4 cont	Weekly	Auxiliary Power Unit - Continued	<div style="text-align: center;">  <p>WARNING</p> </div> <p>a. Open engine deck access doors (WP 0035 00).</p> <p>b. Drain condensation from fuel filters by placing container under filter and opening drain cock to drain water. Close drain cock when clean fuel begins to flow out.</p> <p>c. Check for oil and fuel leaks.</p> <div style="text-align: center;">  <p>FUEL FILTERS</p> <p>DRAIN COCK</p> <p>18i065ma</p> </div> <p>d. Close engine deck access doors (WP 0035 00).</p> <p>e. Inspect and service APU air cleaner (WP 0117 00).</p>	Any fuel leaks or any Class III oil leaks.

PREVENTIVE MAINTENANCE CHECKS AND SERVICES INCLUDING LUBRICATION INSTRUCTIONS - CONTINUED

0105 00

TABLE 4 PREVENTIVE MAINTENANCE CHECKS AND SERVICES, WEEKLY-CONTINUED

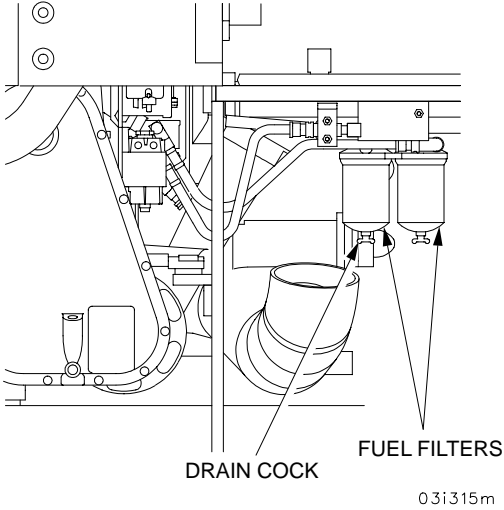
Item No.	Interval	LOCATION	CREWMEMBER Procedure	Not Fully Mission Capable If:
		Item to Check/ Service		
5	Weekly	Auxiliary Power Unit (HATZ)	<div style="text-align: center;">  <div style="border: 2px solid black; padding: 2px; display: inline-block;">WARNING</div> </div> <p>a. Open engine deck access doors (WP 0035 00).</p> <p>b. Drain condensation from fuel filters by placing container under filter and opening drain cock to drain water. Close drain cock when clean fuel begins to flow out.</p> <p>c. Check for oil and fuel leaks.</p> <div style="text-align: center;">  </div> <p>d. Close engine deck access doors (WP 0035 00).</p> <p>e. Inspect and service APU air cleaner (WP 0117 00).</p>	Any fuel leaks or any Class III oil leaks.

PREVENTIVE MAINTENANCE CHECKS AND SERVICES INCLUDING LUBRICATION INSTRUCTIONS - CONTINUED

0105 00

TABLE 4 PREVENTIVE MAINTENANCE CHECKS AND SERVICES, WEEKLY-CONTINUED

Item No.	Interval	LOCATION	CREWMEMBER Procedure	Not Fully Mission Capable If:
		Item to Check/Service		
6	Weekly	Top Hatches	<p><u>DRIVER</u></p> <p>a. Inspect for presence and operation (WP 0026 00).</p> <p>b. Check for loose or damaged crash pads and door seals.</p>	<p>a. Missing/inoperable. Will not lock in open or closed position.</p>

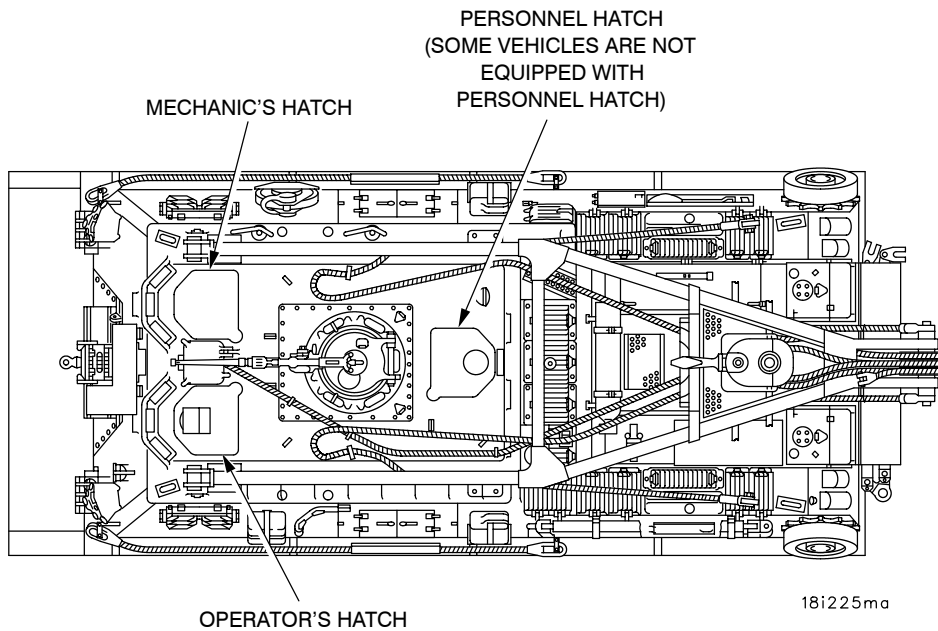

PREVENTIVE MAINTENANCE CHECKS AND SERVICES INCLUDING LUBRICATION INSTRUCTIONS - CONTINUED

0105 00

TABLE 4 PREVENTIVE MAINTENANCE CHECKS AND SERVICES, WEEKLY-CONTINUED

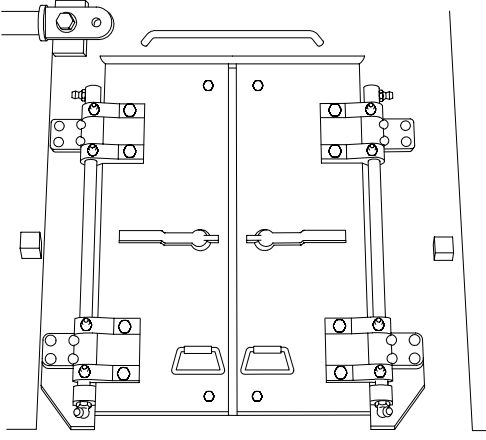
Item No.	Interval	LOCATION	CREWMEMBER Procedure	Not Fully Mission Capable If:
		Item to Check/Service		
7	Weekly	Personnel Side Doors	<p><u>DRIVER</u></p> <p>a. Inspect for presence and operation (WP 0024 00).</p> <p>b. Check for loose or damaged crash pads and door seals.</p>	Missing/inoperable. Will not lock in closed position.
				
18i039m				
8	Weekly	Stowage Boxes and Stowed Equipment	<p><u>DRIVER</u></p> <p>Check condition of boxes and equipment (Table 3 and 4, WP 0136 00) to see if they are present, secure, clean and serviceable.</p>	Equipment necessary for the completion of the mission is damaged or missing.

PREVENTIVE MAINTENANCE CHECKS AND SERVICES INCLUDING LUBRICATION INSTRUCTIONS - CONTINUED

0105 00

TABLE 4 PREVENTIVE MAINTENANCE CHECKS AND SERVICES, WEEKLY-CONTINUED

Item No.	Interval	LOCATION	CREWMEMBER Procedure	Not Fully Mission Capable If:
		Item to Check/Service		
9	Weekly	<u>CREW COMPARTMENT</u> Lights	<u>DRIVER/MECHANIC</u> Check operation of lights (WP 0021 00, WP 0022 00, WP 0023 00).	

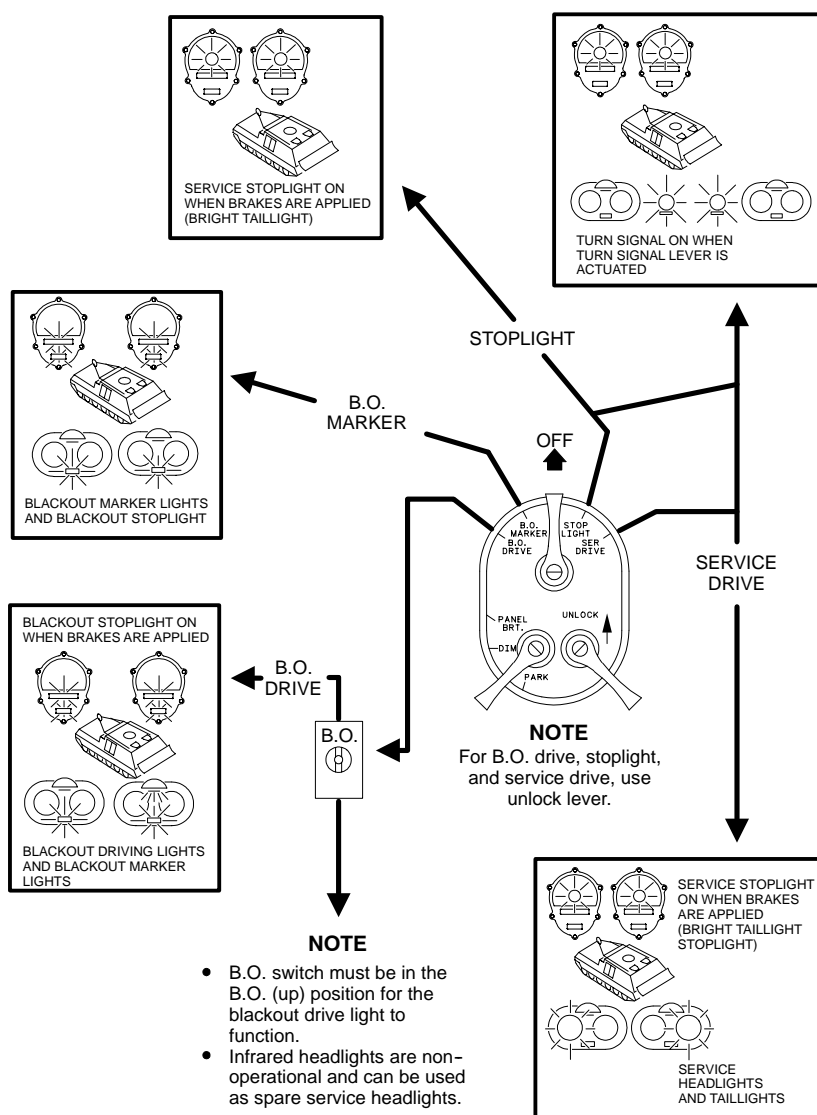



06i156ma

PREVENTIVE MAINTENANCE CHECKS AND SERVICES INCLUDING LUBRICATION INSTRUCTIONS - CONTINUED

0105 00

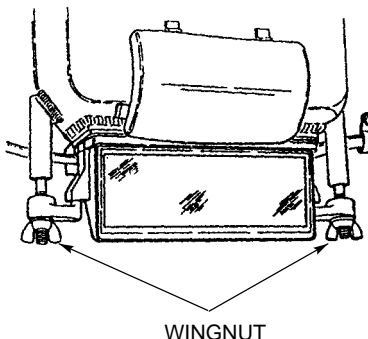
TABLE 4 PREVENTIVE MAINTENANCE CHECKS AND SERVICES, WEEKLY-CONTINUED

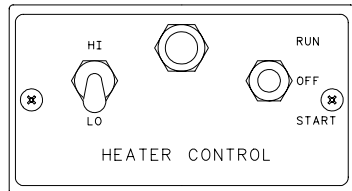
Item No.	Interval	LOCATION	CREWMEMBER Procedure	Not Fully Mission Capable If:
		Item to Check/ Service		
10	Weekly	Driver's Night Vision Viewer (AN/VVS-2(V))	<p><u>DRIVER</u></p> <div style="border: 1px solid black; padding: 5px; text-align: center; width: fit-content; margin: 10px auto;">CAUTION</div> <p>Protect night vision viewer from bright light. Bright light will damage the unit.</p> <p>Inspect equipment in accordance with TM 11-5855-249-10 and check operation in accordance with WP 0059 00.</p>	
11	Weekly	Vision Devices	<p><u>DRIVER</u></p> <p>Check for moisture entering through periscope or vision block mounting (defective seals).</p> <p>Check retaining wingnuts for tightness. Check lens glass surface for dirt, dust or scratches. Use lens paper (item 35, WP 0135 00) to clean lens glass (WP 0119 00).</p> <div style="text-align: center;">  <p>WINGNUT</p> </div> <div style="display: flex; justify-content: center; gap: 20px; margin: 10px 0;">   </div> <div style="border: 2px solid black; padding: 5px; text-align: center; width: fit-content; margin: 10px auto;">WARNING</div>	<p>Vision is over 50% blocked.</p> <p>One or more periscopes broken or missing.</p>
12	Weekly	Personnel Heater	<p>Turn the personnel heater on (WP 0056 00) and check for proper operation. Check for fuel and exhaust leaks.</p> <div style="text-align: center;">  <p>HEATER CONTROL</p> </div>	<p>Any fuel or exhaust leaks exist.</p>

PREVENTIVE MAINTENANCE CHECKS AND SERVICES INCLUDING LUBRICATION INSTRUCTIONS - CONTINUED

0105 00

TABLE 4 PREVENTIVE MAINTENANCE CHECKS AND SERVICES, WEEKLY-CONTINUED

Item No.	Interval	LOCATION	CREWMEMBER Procedure	Not Fully Mission Capable If:
		Item to Check/ Service		
13	Weekly	<p><u>CREW COMPARTMENT</u></p> <p>Gas Particulate Filtration Unit (GPFU)</p>	<p><u>DRIVER</u></p> <div style="text-align: center;">  <div style="border: 2px solid black; padding: 5px; display: inline-block;">WARNING</div> </div> <p>a. Turn switch to ON. Check motor for smooth operation and check outlets for air flow (WP 0068 00).</p> <p>b. Check cable assembly for worn or cracked insulation and loose connections.</p> <p>c. Check all hoses for wear, damage or deterioration.</p> <p>d. Check entire filter unit assembly for dents, cracks, or missing parts.</p> <p>e. Turn M3 heater switch to ON. Check for heated air at air flow outlets.</p> <p style="text-align: center;">NOTE</p> <p>M3 heater must operate 10-15 minutes before heat is felt.</p> <p>f. Check protective mask in accordance with TM 3-4240-280-10.</p>	Does not operate or no air flow.

END OF TASK

PREVENTIVE MAINTENANCE CHECKS AND SERVICES INCLUDING LUBRICATION INSTRUCTIONS - CONTINUED

0105 00

TABLE 5 PREVENTIVE MAINTENANCE CHECKS AND SERVICES, MONTHLY

INITIAL SETUP:

Tools and Special Tools

Gloves (item 16, Table 2, WP 0133 00)

Materials/Parts

Wiping rags (item 45, WP 0135 00)

Personnel Required

Three

References

WP 0050 00

WP 0048 00

WP 0049 00

WP 0133 00

WP 0135 00

Item No.	Interval	LOCATION	CREWMEMBER Procedure	Not Fully Mission Capable If:
		Item to Check/Service		
1	Monthly	<p><u>EXTERIOR</u></p> <p>Main Winch Cable, Hoist Winch Cable, Auxiliary Winch Cable, and Staylines.</p>	<p><u>CREW</u></p> <div style="border: 2px solid black; padding: 5px; text-align: center; margin: 10px 0;">WARNING</div> <p>Cable can become frayed or contain broken wires. Wear heavy leather-palmed work gloves when handling cable. Frayed or broken wires can injure hands.</p> <p>Never let moving cable slide through hands, even when wearing gloves. A broken wire could cut through glove and cut hand.</p> <div style="border: 2px dashed black; padding: 5px; text-align: center; margin: 10px 0;">CAUTION</div> <p>Always keep tension on cable during payout. Slack in cable may cause equipment damage.</p> <p>Ensure main winch cable clevis is seated firmly in trumpet guide when cable is fully retracted. Loose cable may cause level winder malfunction indicator to come on or damage to level winder.</p>	

PREVENTIVE MAINTENANCE CHECKS AND SERVICES INCLUDING LUBRICATION INSTRUCTIONS - CONTINUED

0105 00

TABLE 5 PREVENTIVE MAINTENANCE CHECKS AND SERVICES, MONTHLY - CONTINUED

Item No.	Interval	LOCATION	CREWMEMBER Procedure	Not Fully Mission Capable If:
		Item to Check/ Service		
1 cont	Monthly	Main Winch Cable, Hoist Winch Cable, Auxiliary Winch Cable, and Stay-lines.	<p>Pay-out main winch cable (WP 0050 00), hoist winch cable (WP 0048 00), and auxiliary winch cable (WP 0049 00), inspect for:</p> <ul style="list-style-type: none"> a. Kinked, birdcaged, or crushed cable. b. Abrasion or peening. c. Corrosion deterioration. <p style="text-align: center;">NOTE</p> <p>A rope lay or lay length is the length along the rope in which one strand makes a complete revolution around the rope.</p>	<ul style="list-style-type: none"> a. Cable is kinked, birdcaged, or crushed to the point it cannot be completely wound on drum.
			<ul style="list-style-type: none"> d. Inspect cable for breaks. 	<ul style="list-style-type: none"> b. Six wires in one rope lay are broken. c. Three wires in one strand in one rope lay are broken.

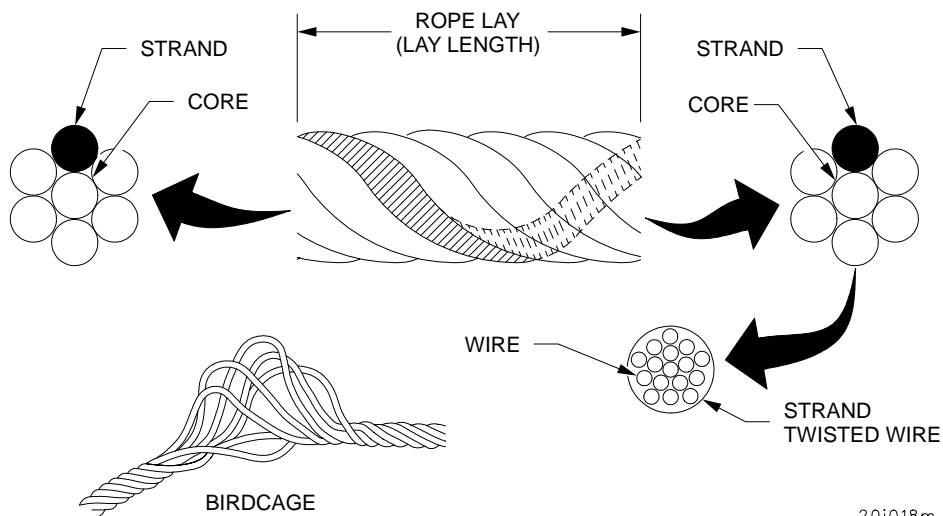

20i018m

END OF TASK

**PREVENTIVE MAINTENANCE CHECKS AND SERVICES INCLUDING
LUBRICATION INSTRUCTIONS - CONTINUED**

0105 00

TABLE 6 LUBRICATION INSTRUCTIONS

SCOPE

This table lists and prescribes cleaning and lubrication procedures as to locations, intervals and proper materials for this vehicle.

GENERAL

1. General. Any special lubricating instructions required for special mechanisms or parts are contained in the pertinent section.
2. Service intervals. Service intervals specified in this Table for normal operations and where moderate temperature, humidity and atmospheric conditions prevail. Report unsatisfactory performance of prescribed fuels, lubricants, or preserving materials, using DA Form 2407, Maintenance Request.

This Table is divided into lubrication intervals. When performing lubrication, refer to daily, monthly, and quarterly intervals as appropriate. Intervals (on-condition or hard time) and the related man-hour times are based on normal operation. The man-hour time specified is the time you need to do all the services prescribed for a particular interval. On-Condition (OC) oil sample intervals shall be applied unless changed by the Army Oil Analysis Program (AOAP) laboratory. Change the hard time interval if your lubricants are contaminated or if you are operating the equipment under adverse operating conditions, including longer than usual operating hours. The hard time interval may be extended during periods of low activity. If extended, adequate preservation precautions must be taken. Hard time intervals will be applied in the event AOAP laboratory support is not available.

Engine oil/transmission oil/hydraulic fluids must be sampled as prescribed by DA PAM 738-750.

Lubrication point pictures with dash lines (- - - -) means there are lubrication points on both sides of the vehicle.

WARNING

All PMCS and scheduled maintenance as required by operation and maintenance manuals must be performed before operating vehicle. Failure to do this may result in personnel injury/death and/or system damage due to system failure or degraded system operation.

PREVENTIVE MAINTENANCE CHECKS AND SERVICES INCLUDING LUBRICATION INSTRUCTIONS - CONTINUED

0105 00

TABLE 6 LUBRICATION INSTRUCTIONS - CONTINUED



WARNING

Clean parts with SOLVENT, DRY-CLEANING (P-D-680).



WARNING

Before you start your lubrication service, observe the following:

- NEVER:
 - a. Use wrong type lubricant.
 - b. Use too much lubricant.
- ALWAYS:
 - a. Clean grease fittings before lubrication.
 - b. Use this lubrication order as your guide.
 - c. Check for lubricant and fuel leaks along with daily services.
 - d. Make sure vehicle is level when checking oil levels: If it isn't, you'll get incorrect readings on dipsticks and sight gauges.
 - e. Lubricate after water fording
- Oil filters shall be serviced/cleaned/changed as applicable, when:
 - a. They are known to be contaminated, or clogged;
 - b. Service is recommended by AOAP laboratory analysis, or
 - c. At prescribed hard time intervals.

NOTE

H Hourly Q Quarterly
 D Daily OC On-Condition
 M Monthly

SYMBOL	NOMENCLATURE	SPECIFICATION
GAA	GREASE	MIL-G-10924
GO	LUBRICATING OIL	MIL-L-2105
OE HDO	LUBRICATING OIL	MIL-L-2104
OEA	LUBRICATING OIL (ARCTIC)	MIL-L-46167
CAT 10	LUBRICATING OIL	CAT TD TO, TO-4
FRH	FIRE RETARDANT HYDRAULIC OIL	MIL-H-46170
PL-S	LUBRICATING OIL	VV-L-800
GRSWR R	GREASE	MIL-G-18458

**PREVENTIVE MAINTENANCE CHECKS AND SERVICES INCLUDING
LUBRICATION INSTRUCTIONS - CONTINUED**

0105 00

TABLE 6 LUBRICATION INSTRUCTIONS - CONTINUED

LUBRICANTS TO BE USED AT EXPECTED TEMPERATURES				
COMPONENT (CAPACITY)	CONTINUOUSLY ABOVE +80° F (Above 27° C)	TYPICALLY +95° F TO -15° F (+35° C TO -10° C)	TYPICALLY +40° F TO -10° F (+5° C TO -23° C)	TYPICALLY 0° F TO -65° F (-17° C TO -54° C)
Main Engine Crankcase (18.5 gal./70.02 L)	OE HDO (30 or 15/40)	OE HDO (30 or 15/40)	OE HDO (10)	OEA
Transmission (17 gal./64.35 L)	CAT 10 (10)	CAT 10 (10)	CAT 10 (10)	OEA
PTO Clutch (5.2 qt./4.94 L)	OE HDO (10)	OE HDO (10)	OE HDO (10)	OEA
Main Winch Gear Case (9.5 gal./36 L)	GO (85/140)	GO (80/90)	GO (80/90)	GO (75 or 80)
Hoist Winch Gear Case (9 pints/4.23 L)	GO (85/140)	GO (80/90)	GO (80/90)	GO (75)
Auxiliary Winch Gear Case (6 pints/2.82 L)	GO (85/140)	GO (80/90)	GO (80/90)	GO (75)
APU Crankcase (3.5 qt./3.31 L)	OE HDO (30 or 15/40)	GO (30 or 15/40)	OE HDO (10)	OEA
APU Chaincase (1 qt./.95 L)	OE HDO (30 or 15/40)	OE HDO (30 or 15/40)	OE HDO (10)	OEA
Hydraulic Reservoir (80 gal./302.80 L)	FRH	FRH	FRH	FRH
All Grease Points (As Required)	GAA	GAA	GAA	GAA
All Oil Can Points (As Required)	PL-S	PL-S	PL-S	PL-S
Hoist Winch Cable (As Required)	OE HDO	OE HDO	OE HDO	OE HDO
Main Winch Cable (As Required)	OE HDO	OE HDO	OE HDO	OE HDO
Auxiliary Winch Cable (As Required)	OE HDO	OE HDO	OE HDO	OE HDO
Boom Stayline Cables (As Required)	GRSWR R	GRSWR R	GRSWR R	GRSWR R
Tow Cables (As Required)	GRSWR R	GRSWR R	GRSWR R	GRSWR R

PREVENTIVE MAINTENANCE CHECKS AND SERVICES INCLUDING LUBRICATION INSTRUCTIONS - CONTINUED

0105 00

TABLE 6 LUBRICATION INSTRUCTIONS - CONTINUED

DAILY

This page shows items to be lubricated daily when operating the vehicle.

	Lubricant	Interval	
HOIST WINCH CABLE (WP 0105 00-76)	OE/HDO	D	
HOIST WINCH OIL LEVEL CHECK (WP 0105 00-76)	GO	D	
ELECTROMAGNETIC CLUTCH OIL LEVEL (WP 0105 00-77)	OE/HDO	D	
MAIN ENGINE CRANKCASE OIL LEVEL CHECK (WP 0105 00-79 or WP 0105 00-80)	OE/HDO	D	
TOWING CABLES (WP 0105 00-81)	GRSWR	D	
TRANSMISSION OIL LEVEL CHECK (WP 0105 00-81)	CAT-10	D	

18i008m

TOTAL MAN-HRS	
INTERVAL MAN-HRS	
D	3.0

PREVENTIVE MAINTENANCE CHECKS AND SERVICES INCLUDING LUBRICATION INSTRUCTIONS - CONTINUED

0105 00

TABLE 6 LUBRICATION INSTRUCTIONS - CONTINUED

DAILY

This page shows items to be lubricated daily when operating the vehicle.

Interval - Lubricant

	D	OE/HDO	AUXILIARY WINCH CABLE (WP 0105 00-86)
	D	OE/HDO	MAIN WINCH CABLE (WP 0105 00-86)
	D	GO	MAIN WINCH OIL LEVEL CHECK (WP 0105 00-87)
	D	OE/HDO	AUXILIARY POWER UNIT CHAINCASE OIL LEVEL CHECK (WP 0105 00-88)
	D	OE/HDO	AUXILIARY POWER UNIT CRANKCASE OIL LEVEL CHECK (WP 0105 00-88)

18i008m

TOTAL MAN-HRS	
INTERVAL MAN-HRS	
D	3.0

PREVENTIVE MAINTENANCE CHECKS AND SERVICES INCLUDING LUBRICATION INSTRUCTIONS - CONTINUED

0105 00

TABLE 6 LUBRICATION INSTRUCTIONS - CONTINUED

1. HOIST WINCH CABLE

WARNING

Cable can become frayed or contain broken wires. Wear heavy leather-palmed work gloves when handling cable. Frayed or broken wires can injure hands. Never let moving cable slide through hands, even when wearing gloves (item 16, Table 2, WP 0133 00). A broken wire could cut through glove and cut hand.

CAUTION

Keep tension on cable during payout and inhaul operations. Failure to do so may result in equipment damage.

DAILY - If winch has been used, unwind used portion of cable and clean. Lubricate with OE/HDO. Rewind cable on drum.

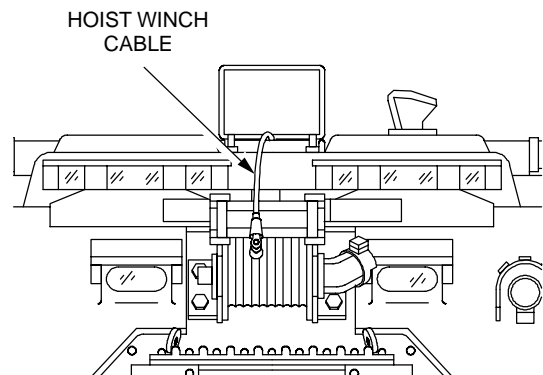

201069ma

2. HOIST WINCH OIL LEVEL CHECK

Park vehicle on level surface. Open subfloor access door (WP 0036 00).

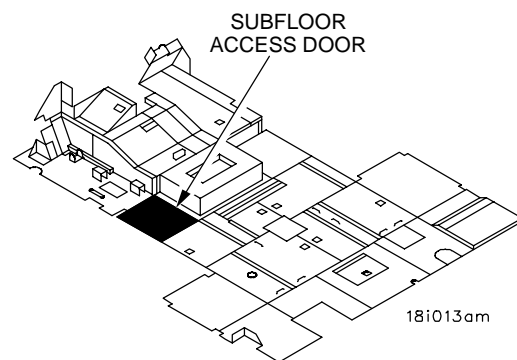

18i013am

NOTE

Oil level must be checked while oil is cold, failure to check while oil is cold will result in an incorrect oil level reading.

Verify oil level is between the middle and top of the sight gauge.

NOTE

Do not fill above top of sight gauge, as correct oil level cannot be determined.

If oil is below the middle of the sight gauge, remove the vent/fill plug and add proper grade oil (WP 0105 00-73) until the oil level is between the middle and top of the sight gauge. Clean vent/fill plug with P-D-680, Item 11, WP 0135 00 and install.

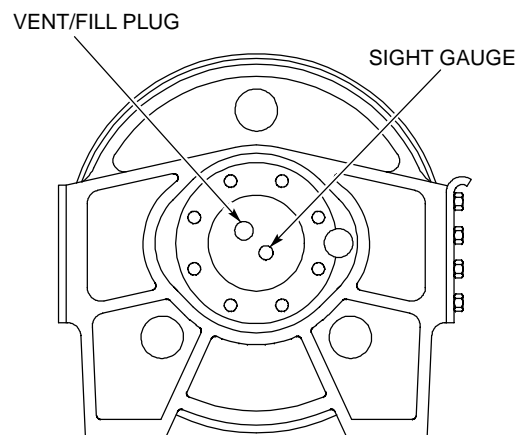

HOIST WINCH DRAIN PLUG IS LOCATED IN WINCH DRUM

PREVENTIVE MAINTENANCE CHECKS AND SERVICES INCLUDING LUBRICATION INSTRUCTIONS - CONTINUED

0105 00

TABLE 6 LUBRICATION INSTRUCTIONS - CONTINUED

3. ELECTROMAGNETIC CLUTCH OIL LEVEL CHECK

Park vehicle on level surface. Start main engine (WP 0012 00) and operate electromagnetic clutch for five minutes. Shut off engine (WP 0019 00). Open subfloor access door (WP 0036 00), remove bayonet gauge and wipe clean. Reinsert bayonet gauge. Remove bayonet gauge and verify oil level reaches the F (full) mark. If required, add proper grade oil (WP 0105 00-73) through bayonet gauge hole until oil level reaches full mark on bayonet gauge.

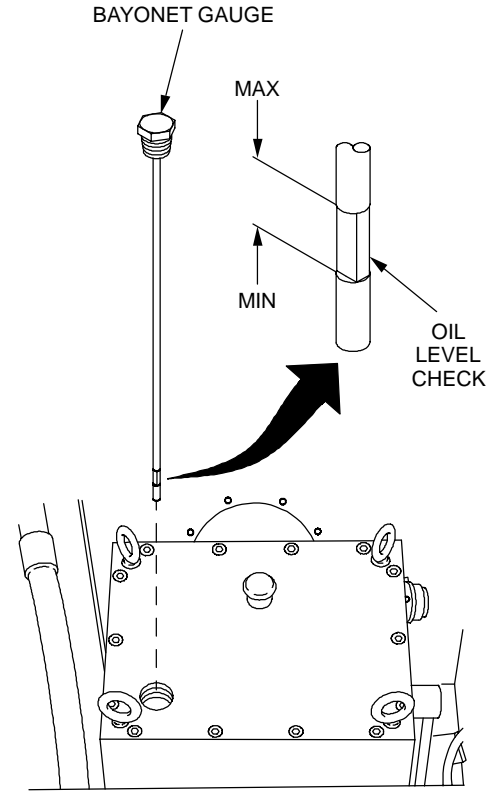

24i003md

PREVENTIVE MAINTENANCE CHECKS AND SERVICES INCLUDING LUBRICATION INSTRUCTIONS - CONTINUED

0105 00

TABLE 6 LUBRICATION INSTRUCTIONS - CONTINUED

4. MAIN ENGINE CRANKCASE OIL LEVEL CHECK

WARNING

Engine oil can be ignited by hot engine surfaces. To avoid engine fire, use offset funnel (item 45, Table 2, WP 0133 00) and utility jug (item 46, Table 2, WP 0133 00) to add engine oil, clean oil from around oil filler tube area with wiping rags (item 45, WP 0135 00) after filling. Make sure engine oil filler tube cap is closed and engine oil fill access door is closed and latched.

CAUTION

Perform engine oil check with vehicle on a level surface and engine stopped for at least two hours.

Do not use ENG. IDLING RANGE side of oil gauge rod to measure engine oil level. Use of ENG. IDLING RANGE side of oil gauge rod could result in equipment damage.

Park vehicle on level surface. Open engine deck door (WP 0031 00). Open engine oil level and check access door. Remove oil gauge rod and wipe clean. Insert oil gauge rod in gauge tube. Remove oil gauge rod. Verify oil level on STATIC ENG. side of oil gauge rod is between FULL and 1-gallon range. If oil level is below FULL, add amount of proper grade oil (WP 0105 00-73) indicated on the oil gauge rod. To add oil, pull engine oil filler tube cap handle and open engine oil filler tube. Insert offset funnel (item 45, Table 2, WP 0133 00) in oil filler tube. Pour quantity of oil indicated on gauge rod into graduated 2.5 gallon utility jug (item 46, Table 2, WP 0133 00). Add oil through engine oil filler tube. Close oil filler tube cap and all access doors.

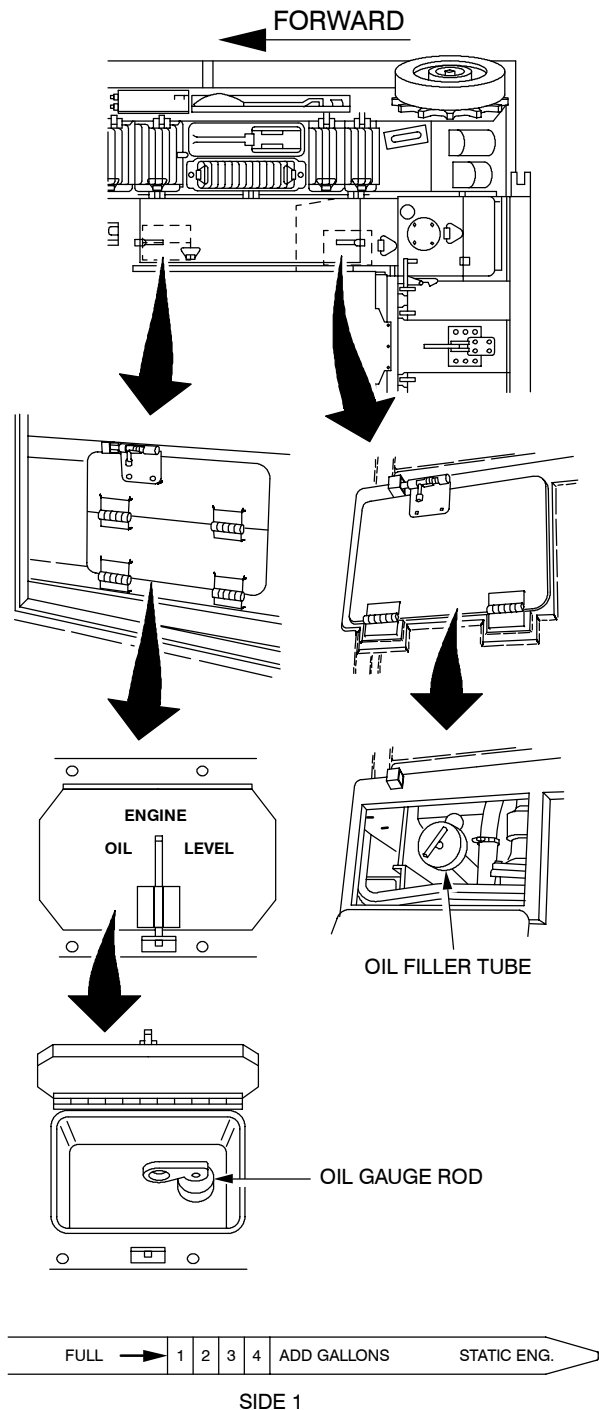

181152mi

PREVENTIVE MAINTENANCE CHECKS AND SERVICES INCLUDING LUBRICATION INSTRUCTIONS - CONTINUED

0105 00

TABLE 6 LUBRICATION INSTRUCTIONS - CONTINUED

5. MAIN ENGINE CRANKCASE OIL LEVEL CHECK (NEW)

WARNING

Engine oil can be ignited by hot engine surfaces. To avoid engine fire, use offset funnel (item 45, Table 2, WP 0133 00) and utility jug (item 46, Table 2, WP 0133 00) to add engine oil, clean oil from around oil filler tube area with wiping rags (item 45, WP 0135 00) after filling. Make sure engine oil filler tube cap is closed and engine oil fill access door is closed and latched.

CAUTION

Perform engine oil check with vehicle on a level surface and engine stopped for at least two hours.

Do not use ENG. IDLING RANGE side of oil gauge rod to measure engine oil level. Use of ENG. IDLING RANGE side of oil gauge rod could result in equipment damage. Park vehicle on level surface. Open engine deck door (WP 0031 00). Open engine oil level and check access door. Remove oil gauge rod and wipe clean. Insert oil gauge rod in gauge tube. Remove oil gauge rod. Verify oil level on STATIC ENG. side of oil gauge rod is between FULL and 1-gallon range. If oil level is below FULL, add amount of proper grade oil (WP 0105 00-73) indicated on the oil gauge rod. To add oil, pull engine oil filler tube cap handle and open engine oil filler tube. Insert offset funnel (item 45, Table 2, WP 0133 00) in oil filler tube. Pour quantity of oil indicated on gauge rod into graduated 2.5 gallon utility jug (item 46, Table 2, WP 0133 00). Add oil through engine oil filler tube. Close oil filler tube cap and all access doors.

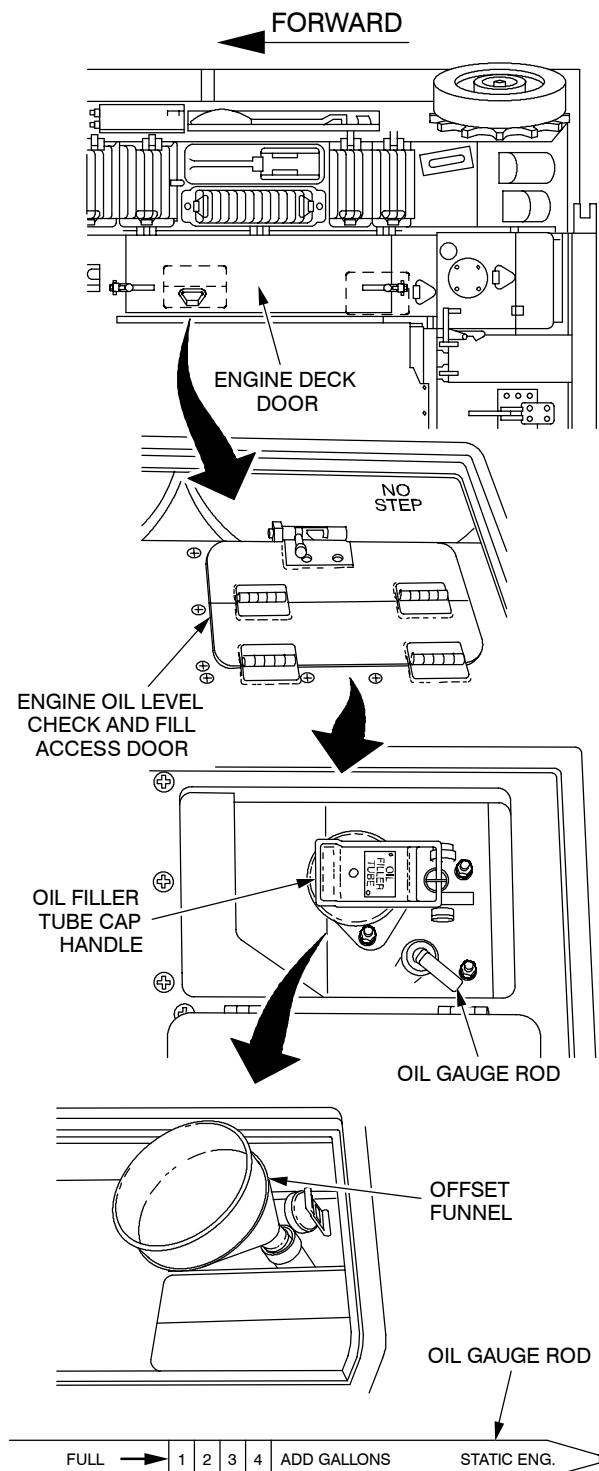

18i266m

PREVENTIVE MAINTENANCE CHECKS AND SERVICES INCLUDING LUBRICATION INSTRUCTIONS - CONTINUED

0105 00

TABLE 6 LUBRICATION INSTRUCTIONS - CONTINUED

6. TOWING CABLES

WARNING

Cable rope can become frayed or contain broken wires. Wear heavy leather-palmed work gloves (item 18, Table 2, WP 0133 00) when handling cable. Frayed or broken wires can injure hands.

DAILY - If towing cables have been used, clean cable, then lubricate with GRSWR.

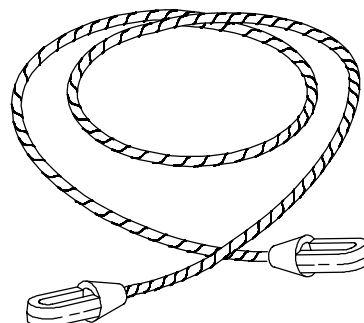

18i192ma

7. TRANSMISSION OIL LEVEL CHECK

To verify that sufficient oil is present in the transmission to permit engine to be started.

CAUTION

Transmission oil level must be checked prior to starting vehicle engine to ensure that sufficient oil is present to permit starting. If vehicle is operated with transmission oil level below ADD mark on the oil level gauge rod, reliability and durability of transmission may be reduced.

Open left side engine deck exhaust grille and exhaust deflector (WP 0032 00). Open transmission oil filler tube access doors. Remove oil gauge rod from oil filler tube and clean oil gauge rod. Insert oil gauge rod into transmission oil filler tube. Remove oil gauge rod and verify that oil is present on oil gauge rod.

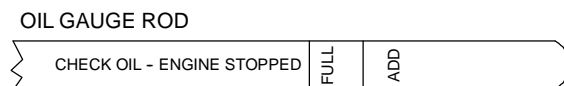
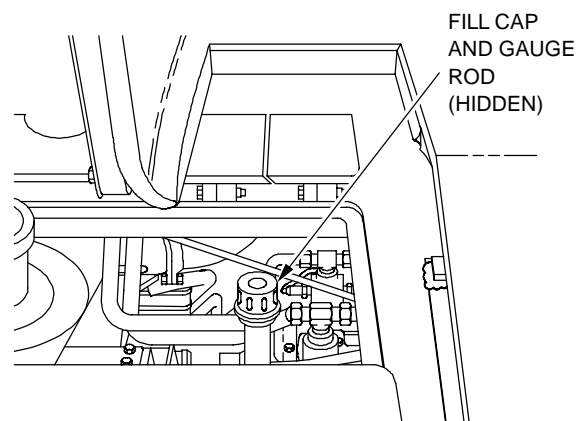
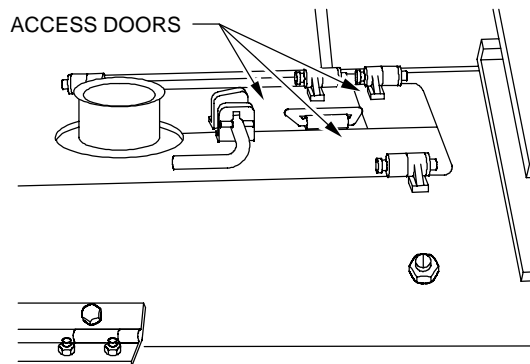

07i095m

PREVENTIVE MAINTENANCE CHECKS AND SERVICES INCLUDING LUBRICATION INSTRUCTIONS - CONTINUED

0105 00

TABLE 6 LUBRICATION INSTRUCTIONS - CONTINUED

7. TRANSMISSION OIL LEVEL CHECK - CONTINUED

If no oil is present on oil gauge rod, add enough proper grade oil (WP 0105 00-73) to transmission until oil level is visible on oil gauge rod below ADD mark.

NOTE

Transmission oil sampling valve may be used to remove excess oil from transmission.

If indicated oil level is above FULL mark on oil gauge rod, start engine and remove excess oil from transmission. Re-install transmission oil gauge rod into transmission oil filler tube, close oil filler tube access doors, left side engine deck exhaust grille and exhaust deflector (WP 0032 00).

CAUTION

The transmission oil level is now adequate to permit vehicle engine to be started, but not to perform vehicle operation. Failure to perform the transmission oil level check prior to vehicle operation could result in transmission damage.

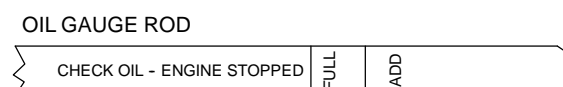
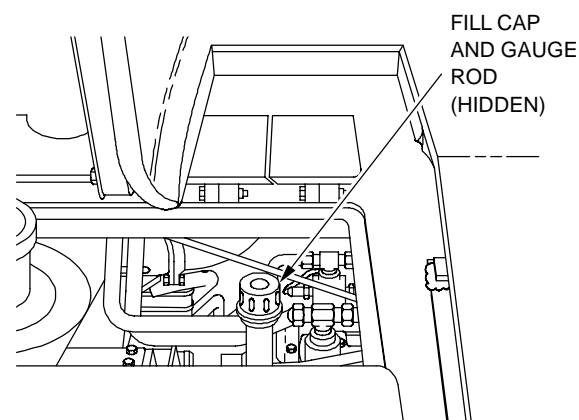
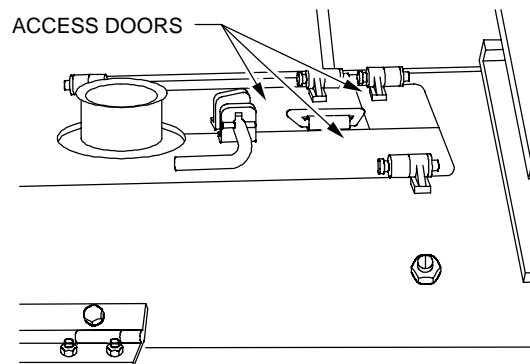

071095m

**PREVENTIVE MAINTENANCE CHECKS AND SERVICES INCLUDING
LUBRICATION INSTRUCTIONS - CONTINUED**

0105 00

TABLE 6 LUBRICATION INSTRUCTIONS - CONTINUED

7. TRANSMISSION OIL LEVEL CHECK - CONTINUED

To verify that sufficient oil is present in the transmission to permit vehicle operation.



WARNING



WARNING



WARNING

WARNING

If vehicle is operated with transmission oil level above the FULL mark on oil gauge rod, smoke and fire may occur in vehicle exhaust system, resulting in damage to equipment or death to personnel.

CAUTION

If vehicle is operated with transmission oil level below ADD mark, reliability and durability of transmission may be reduced.

NOTE

The transmission assembly includes several compartments that contains oil. The transmission assembly also includes several pumps that transfer oil between these compartments.

PREVENTIVE MAINTENANCE CHECKS AND SERVICES INCLUDING LUBRICATION INSTRUCTIONS - CONTINUED

0105 00

TABLE 6 LUBRICATION INSTRUCTIONS - CONTINUED

7. TRANSMISSION OIL LEVEL CHECK - CONTINUED

Park vehicle on a level surface with parking brake applied. Operate engine (WP 0012 00) and warm transmission oil to temperature between 180° to 200°F (82° to 93°C). To reach desired transmission oil temperature it may be necessary to perform high range stall. To perform high range stall: depress and hold brake in applied position, place transmission in 3rd range and run engine at full throttle for no longer than 30 seconds. Return engine speed to idle. If required, repeat procedure after 60 seconds of idling to attain proper transmission oil temperature. Shut down engine (WP 0019 00).

CAUTION

To verify that proper transmission oil is present, it is very important that transmission oil is at correct temperature and that correct amount of time (3-5 minutes) has passed before reading gauge rod. Failure to comply may result in an inaccurate oil level reading. If vehicle is operated with transmission oil level below ADD mark, reliability and durability of the transmission may be reduced.

Open left side engine deck grille and exhaust deflector (WP 0032 00). Open transmission oil filler tube access doors. Remove oil gauge rod from filler tube, clean oil gauge rod. Insert oil gauge rod into transmission oil filler tube. Remove oil gauge rod and verify that oil level is between ADD and FULL marks.

NOTE

Excess oil may be removed from transmission using the AOAP valve.

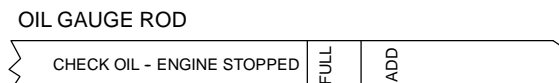
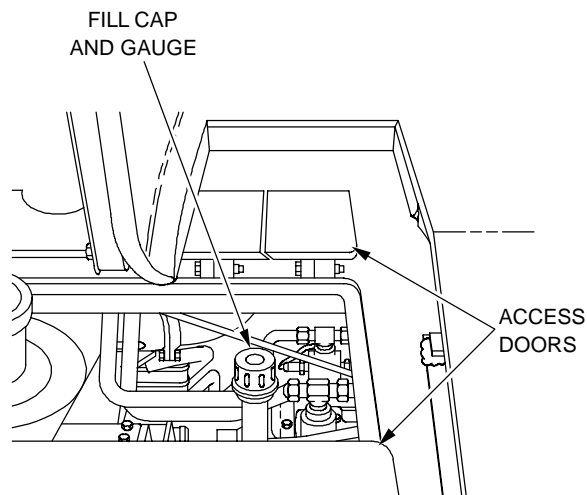

071096m

PREVENTIVE MAINTENANCE CHECKS AND SERVICES INCLUDING LUBRICATION INSTRUCTIONS - CONTINUED

0105 00

TABLE 6 LUBRICATION INSTRUCTIONS - CONTINUED

7. TRANSMISSION OIL LEVEL CHECK - CONTINUED

If indicated oil level is above FULL mark on the oil gauge rod, remove excess amount of oil from transmission.

NOTE

1/2 inch (12.7 mm) on oil gauge rod equals about one gallon of oil.

If indicated oil level is below ADD mark on oil gauge rod, add enough proper grade oil (WP 0105 00-73) to transmission to bring oil level between ADD and FULL marks. Start engine (WP 0012 00) and warm transmission to 180° to 200°F (82° to 93°C). Shut down engine (WP 0019 00).



To verify that proper transmission oil is present, it is very important that transmission oil is at correct temperature and that correct amount of time (3-5 minutes) has passed before reading gauge rod. Failure to comply may result in an inaccurate oil level reading. If the vehicle is operated with transmission oil level below ADD mark reliability and durability of the transmission assembly may be reduced.

Check transmission oil level again to verify that oil levels are between ADD and FULL marks. Re-install oil gauge rod into oil filler tube. Close transmission oil filler tube access doors, close left side engine deck exhaust grille and exhaust deflector (WP 0032 00).

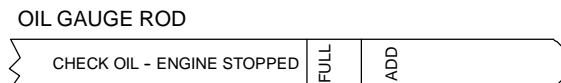
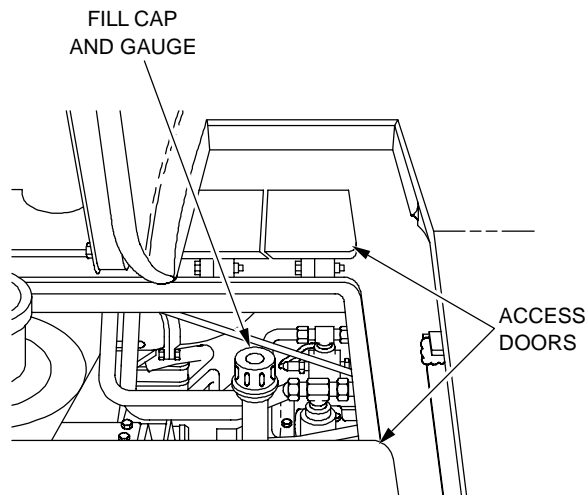

071096m

PREVENTIVE MAINTENANCE CHECKS AND SERVICES INCLUDING LUBRICATION INSTRUCTIONS - CONTINUED

0105 00

TABLE 6 LUBRICATION INSTRUCTIONS - CONTINUED

8. AUXILIARY WINCH CABLE

WARNING

Cable can become frayed or contain broken wires. Wear heavy leather-palmed work gloves (item 16, Table 2, WP 0133 00) when handling cable. Frayed or broken wires can injure hands. Never let moving cable slide through hands, even when wearing gloves (item 16, Table 2, WP 0133 00). A broken wire could cut through glove and cut hand.

CAUTION

Keep tension on cable during payout and inhaul operations. Failure to do so may result in equipment damage.

DAILY - If winch has been used, unwind used portion of cable. Clean cable, then lubricate with OE/HDO. Rewind cable on drum.

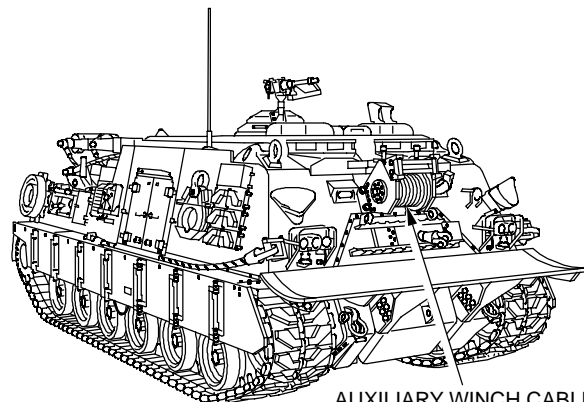

AUXILIARY WINCH CABLE
20i134m

9. MAIN WINCH CABLE

WARNING

Cable can become frayed or contain broken wires. Wear heavy leather-palmed work gloves when handling cable. Frayed or broken wires can injure hands. Never let moving cable slide through hands, even when wearing gloves (item 16, Table 2, WP 0133 00). A broken wire could cut through glove and cut hand.

CAUTION

Keep tension on cable during payout and inhaul operations. Failure to do so may result in equipment damage.

DAILY - If winch has been used, unwind used portion of cable. Clean cable, then lubricate with OE/HDO. Rewind cable onto drum.

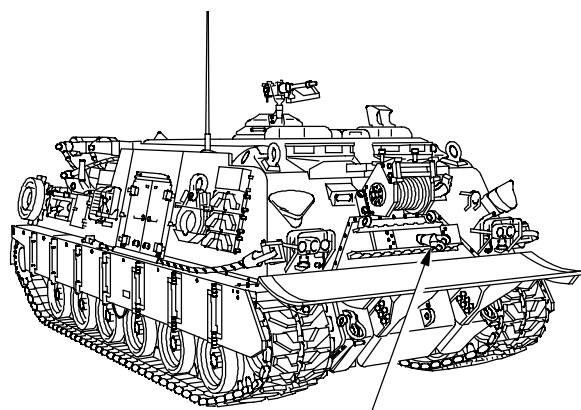

MAIN WINCH CABLE
20i135m

**PREVENTIVE MAINTENANCE CHECKS AND SERVICES INCLUDING
LUBRICATION INSTRUCTIONS - CONTINUED****0105 00****TABLE 6 LUBRICATION INSTRUCTIONS - CONTINUED****10. MAIN WINCH OIL LEVEL CHECK**

Park vehicle on a level surface. Remove three screws, three flat washers and subfloor access plate. Remove bayonet gauge, wipe clean, insert, remove again and verify oil level reaches FULL mark.

To add oil to main winch, remove the bayonet gauge, install a funnel (item 15, Table 2, WP 0133 00) in the tube and add the proper grade oil (WP 0105 0073). Check oil level with the bayonet gauge. Add oil until the oil level reaches the full mark. Remove the funnel and install the bayonet gauge.

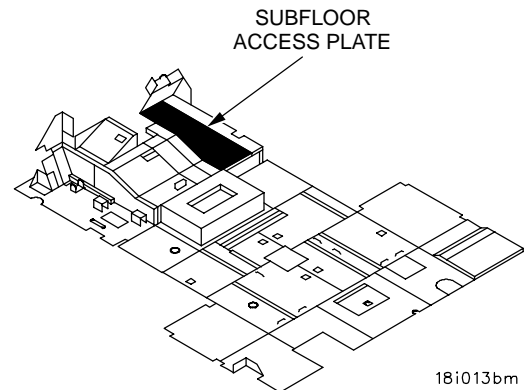
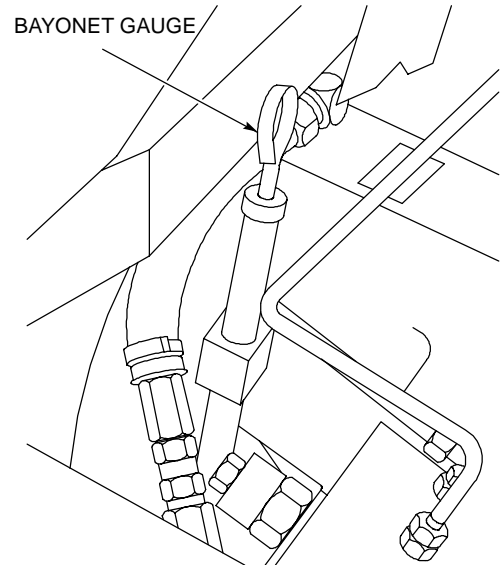

18i013bm

PREVENTIVE MAINTENANCE CHECKS AND SERVICES INCLUDING LUBRICATION INSTRUCTIONS - CONTINUED

0105 00

TABLE 6 LUBRICATION INSTRUCTIONS - CONTINUED

11. AUXILIARY POWER UNIT CHAINCASE OIL LEVEL CHECK



WARNING

Park vehicle on a level surface. Remove front engine deck grilles (WP 0033 00). Remove filler plug. Verify oil level reaches bottom of threads in fill hole. If required, add proper grade oil (WP 0105 00-73) to chaincase through fill hole until oil level reaches threads. Clean fill plug with P-D-680 (item 11, WP 0135 00) and install. Install front engine deck grilles (WP 0033 00).

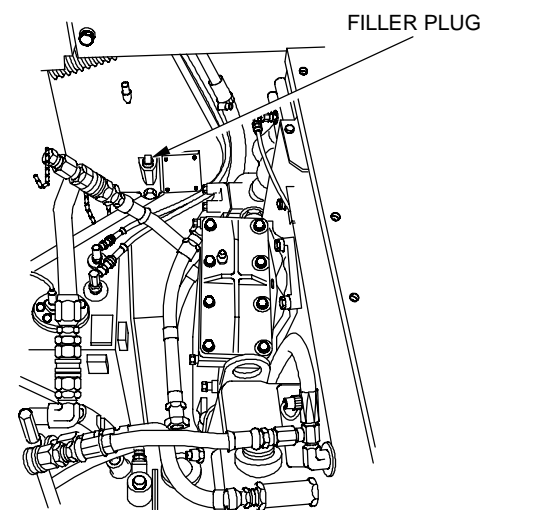
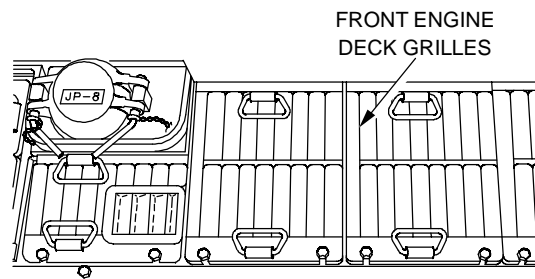

12. AUXILIARY POWER UNIT CRANKCASE OIL LEVEL CHECK

WARNING

Park vehicle on a level surface. Open APU access door (WP 0030 00). Remove bayonet gauge, wipe clean with rag and insert. Remove bayonet gauge again and verify oil level reaches the FULL mark. Remove filler cap and add proper grade oil (WP 0105 00-73), if required, until oil level reaches the FULL mark on the bayonet gauge. Insert the bayonet gauge and filler cap. Close the APU access door (WP 0030 00).

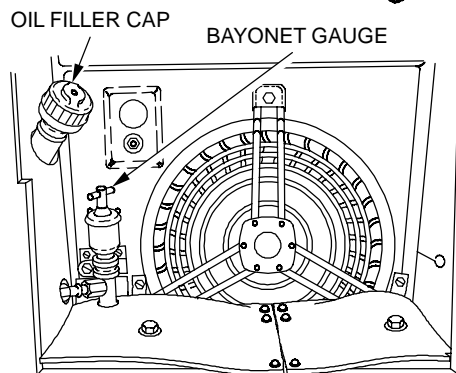
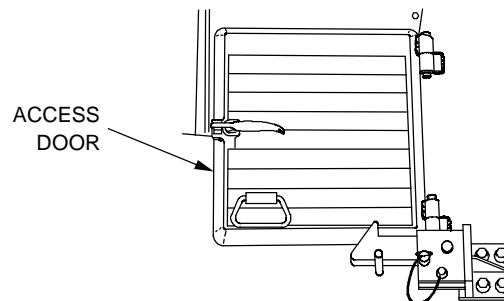

29i062m

**PREVENTIVE MAINTENANCE CHECKS AND SERVICES INCLUDING
LUBRICATION INSTRUCTIONS - CONTINUED**

0105 00

TABLE 6 LUBRICATION INSTRUCTIONS - CONTINUED

13. AUXILIARY POWER UNIT CRANKCASE OIL LEVEL CHECK (HATZ)

WARNING

Park vehicle on a level surface. Open APU access door (WP 0030 00).

Remove saber gauge, wipe clean with wiping rag (item 45, WP 0135 00) and insert. Remove saber gauge again and verify oil level reaches the FULL mark. Remove filler cap and add proper grade oil (WP 0105 00-73), if required, until oil level reaches the FULL mark on the saber gauge.

Close the APU access door (WP 0030 00).

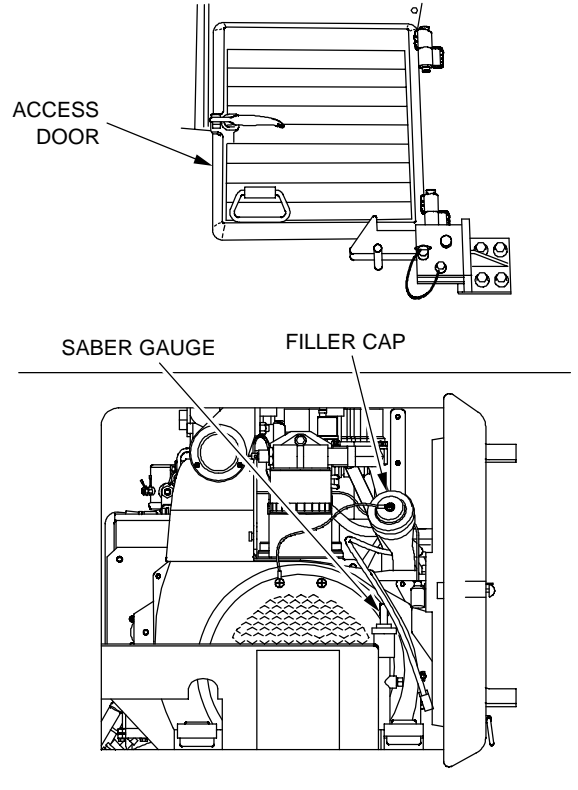

29i084m

**PREVENTIVE MAINTENANCE CHECKS AND SERVICES INCLUDING
LUBRICATION INSTRUCTIONS - CONTINUED**

0105 00

TABLE 6 LUBRICATION INSTRUCTIONS - CONTINUED

MONTHLY

This page shows items to be lubricated monthly when operating the vehicle.

Lubricant - Interval

MAIN ENGINE
AOAP SAMPLING
(WP 0105 00-91)

TRANSMISSION
AOAP SAMPLING
(WP 0105 00-91)

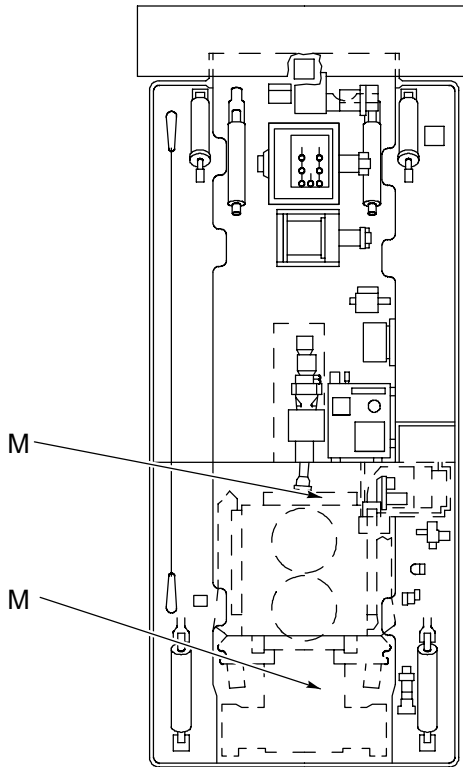

18i008m

TOTAL MAN-HR	
INTERVAL MAN-HR	
M	1.0

PREVENTIVE MAINTENANCE CHECKS AND SERVICES INCLUDING LUBRICATION INSTRUCTIONS - CONTINUED

0105 00

TABLE 6 LUBRICATION INSTRUCTIONS - CONTINUED

14. MAIN ENGINE AOAPSAMPLING

NOTE

Refer to Army Oil Analysis Program (AOAP) TB 43-0210.

Park vehicle on a level surface. Remove front engine deck grilles (WP 0033 00). Remove protective cap from sampling valve. Position sample collection bottle under sampling valve. Lift sampling valve control and fill bottle to required level.



Make sure oil sampling valve lever is parallel to oil filter cover and that protective cap is installed and secured on sampling valve. Failure to properly position oil sampling valve lever and secure protective cap may result in loss of engine oil and equipment damage.

Install protective cap on sampling valve. Install front engine deck grilles (WP 0033 00).

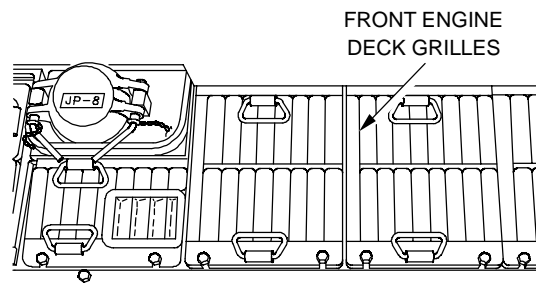

FRONT ENGINE DECK GRILLES

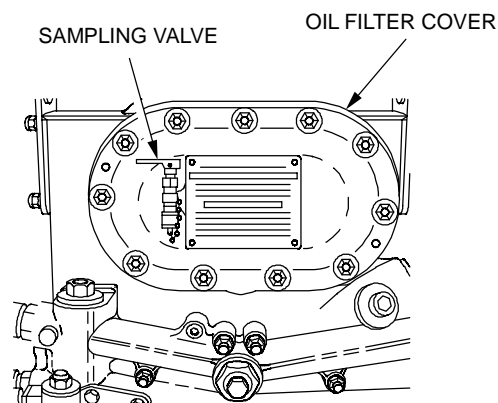

SAMPLING VALVE

OIL FILTER COVER

15. TRANSMISSION AOAP SAMPLING

NOTE

Refer to Army Oil Analysis Program (AOAP) TB 43-0211.

Park vehicle on a level surface. Open engine exhaust grille door and exhaust pipe door (WP 0032 00). Remove protective cap from sampling valve. Position sample collection bottle under sampling valve. Lift sampling valve control and fill bottle to required level. Install protective cap on sampling valve. Close exhaust pipe door and engine exhaust grille door (WP 0032 00).

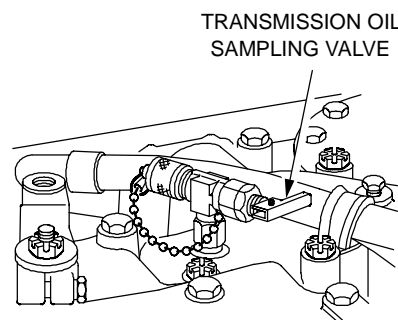

TRANSMISSION OIL SAMPLING VALVE

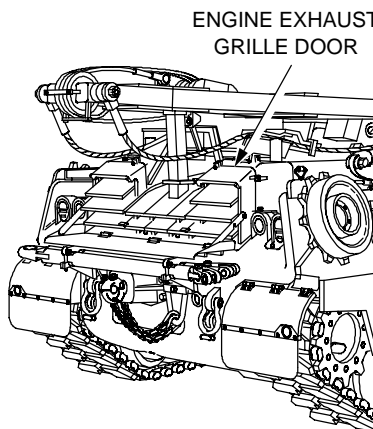

ENGINE EXHAUST GRILLE DOOR

01i317m

TABLE 6 LUBRICATION INSTRUCTIONS - CONTINUED

QUARTERLY

Interval - Lubricant

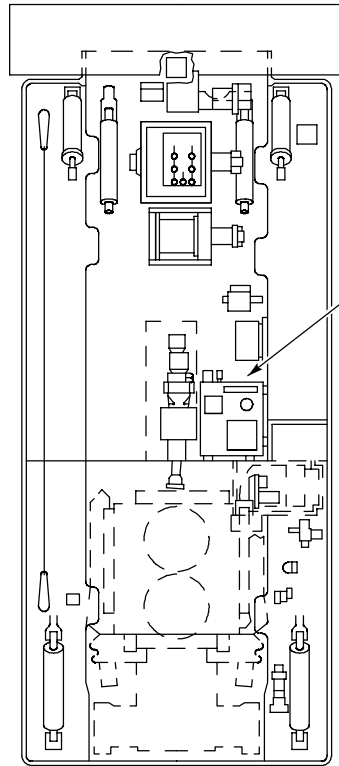

Q

FRH

HYDRAULIC
RESERVOIR OIL
LEVEL CHECK
(WP 0105 00-94)

18i008m

**PREVENTIVE MAINTENANCE CHECKS AND SERVICES INCLUDING
LUBRICATION INSTRUCTIONS - CONTINUED**

0105 00

TABLE 6 LUBRICATION INSTRUCTIONS - CONTINUED

QUARTERLY

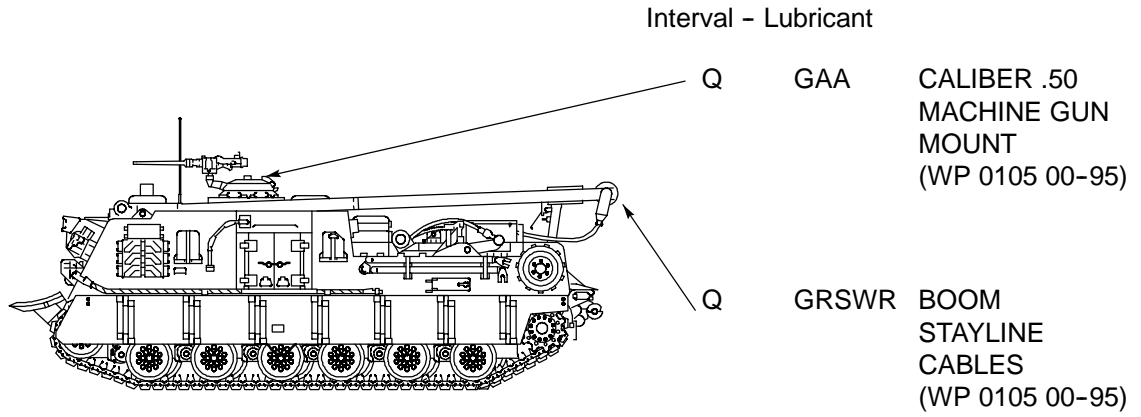

PREVENTIVE MAINTENANCE CHECKS AND SERVICES INCLUDING LUBRICATION INSTRUCTIONS - CONTINUED

0105 00

TABLE 6 LUBRICATION INSTRUCTIONS - CONTINUED

16. HYDRAULIC RESERVOIR OIL LEVEL CHECK (C)



WARNING

CAUTION

Do not over fill hydraulic reservoir with boom in down position. When boom is raised, hydraulic fluid will overflow out of the bayonet gage neck. Overfilling may cause damage to equipment.

Park vehicle on a level surface. Remove two screws, two flat washers, and subfloor access plate. Remove bayonet gage, wipe clean and insert. Remove bayonet gage and verify oil is above the DANGER mark. If required, remove filler cap and add proper grade oil (WP 0105 00-73) to bring oil level above DANGER mark. Insert bayonet gage. Start main engine (WP 0012 00) and operate hydraulic system until hydraulic oil is at operating temperature. Shut off main engine (WP 0019 00). Remove bayonet gage and verify that oil level on HOT side of bayonet gage reaches the lower FULL mark with the boom down or the upper FULL mark with the boom up. If required, remove filler cap and add additional oil. Install filler cap and bayonet gage. Install subfloor access plate.

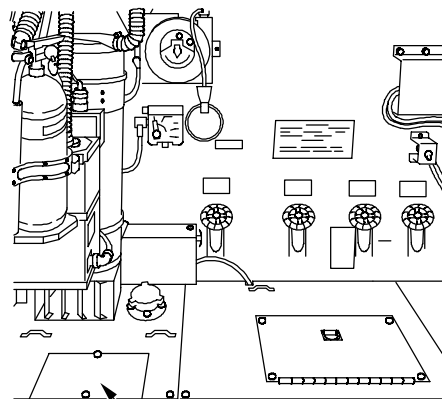

SUBFLOOR ACCESS PLATE

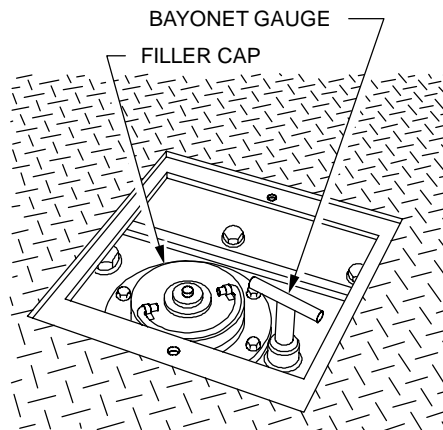

BAYONET GAUGE FILLER CAP

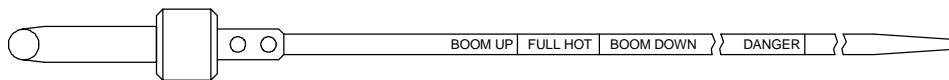

24i005m

**PREVENTIVE MAINTENANCE CHECKS AND SERVICES INCLUDING
LUBRICATION INSTRUCTIONS - CONTINUED**

0105 00

TABLE 6 LUBRICATION INSTRUCTIONS - CONTINUED

17. CALIBER .50 MACHINE GUN MOUNT

Clean and lubricate moving surfaces and sleeve with GAA.

18. BOOM STAYLINE CABLES

WARNING

Cable can become frayed or contain broken wires. Wear heavy leather-palmed work gloves (item 16, Table 2, WP 0133 00) when handling cable. Frayed or broken wires can injure hands.

Clean cable, then coat with GRSW R.

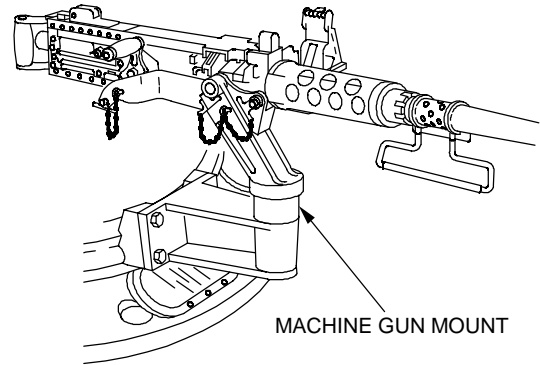

18i027m

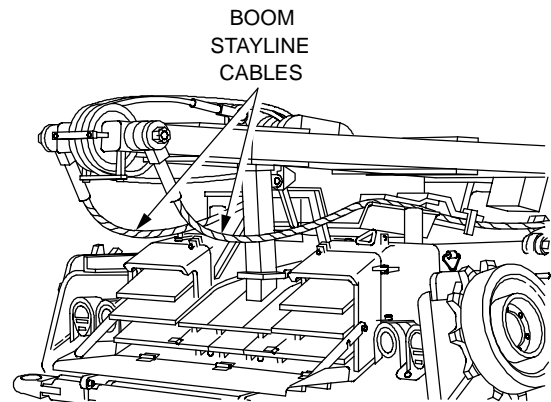

18i026m

PREVENTIVE MAINTENANCE CHECKS AND SERVICES INCLUDING LUBRICATION INSTRUCTIONS - CONTINUED

0105 00

TABLE 6 LUBRICATION INSTRUCTIONS - CONTINUED

IRREGULAR INTERVALS

The following lubrications are not based on any calendar period. They are performed after fording, operation in mud or dust.

Lubricant - Interval

- STEERING LINKAGE (WP 0105 00-100) GAA OC
- STEERING LINKAGE BELLCRANK (WP 0105 00-100) GAA OC
- STEERING CONTROL ASSEMBLY (WP 0105 00-101) GAA OC

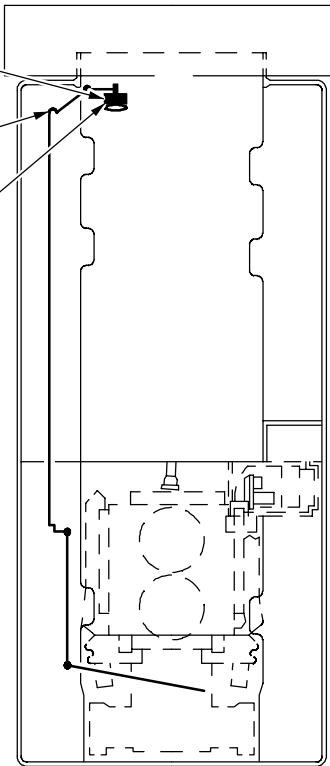

14i031m

TOTAL MAN-HRS	
INTERVAL MAN-HRS	
OC	.10

PREVENTIVE MAINTENANCE CHECKS AND SERVICES INCLUDING LUBRICATION INSTRUCTIONS - CONTINUED

0105 00

TABLE 6 LUBRICATION INSTRUCTIONS - CONTINUED

IRREGULAR INTERVALS

The following lubrications are not based on any calendar period. They are performed after fording, operation in mud or dust.

Interval - Lubricant

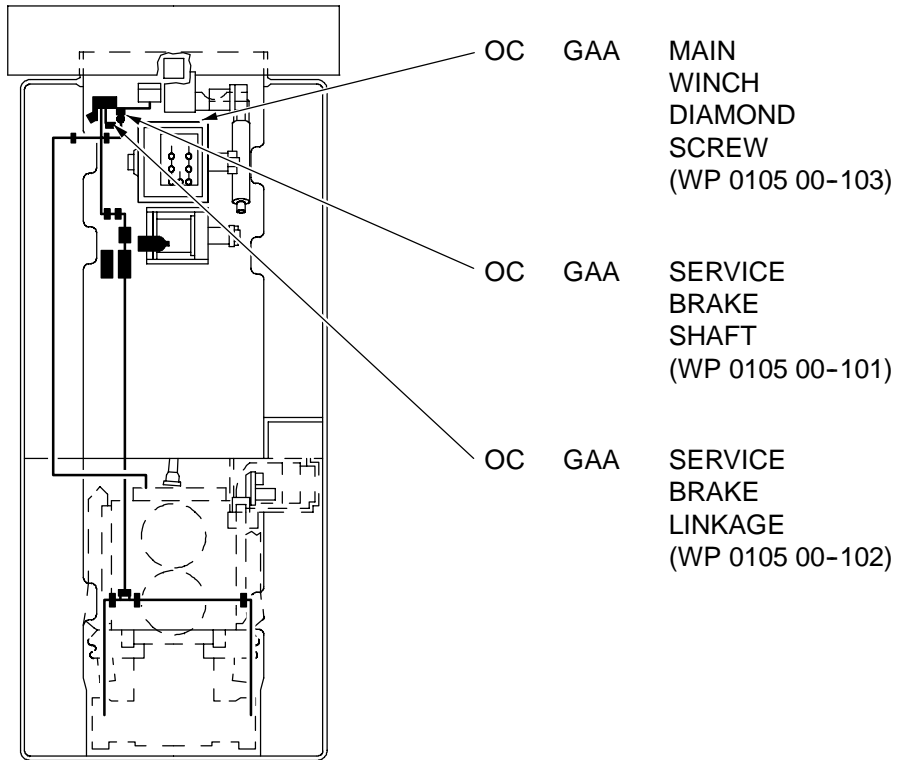

12i045m

TOTAL MAN-HRS	
INTERVAL MAN-HRS	
OC	.40

PREVENTIVE MAINTENANCE CHECKS AND SERVICES INCLUDING LUBRICATION INSTRUCTIONS - CONTINUED

0105 00

TABLE 6 LUBRICATION INSTRUCTIONS - CONTINUED

IRREGULAR INTERVALS

The following lubrications are not based on any calendar period. They are performed after fording, operation in mud or dust.

Interval - Lubricant

ARMOR SKIRTS
REMOVED FOR CLARITY

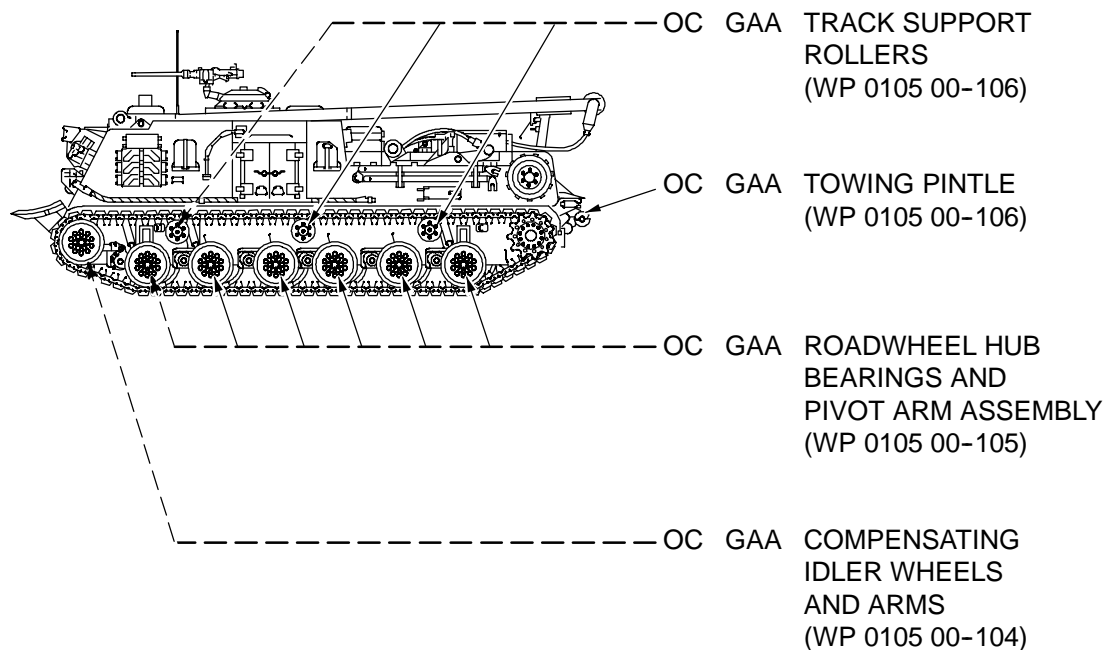

TOTAL MAN-HRS	
INTERVAL MAN-HRS	
OC	.5

TABLE 6 LUBRICATION INSTRUCTIONS - CONTINUED

IRREGULAR INTERVALS

The following lubrications are not based on any calendar period. They are performed after fording, operation in mud or dust.

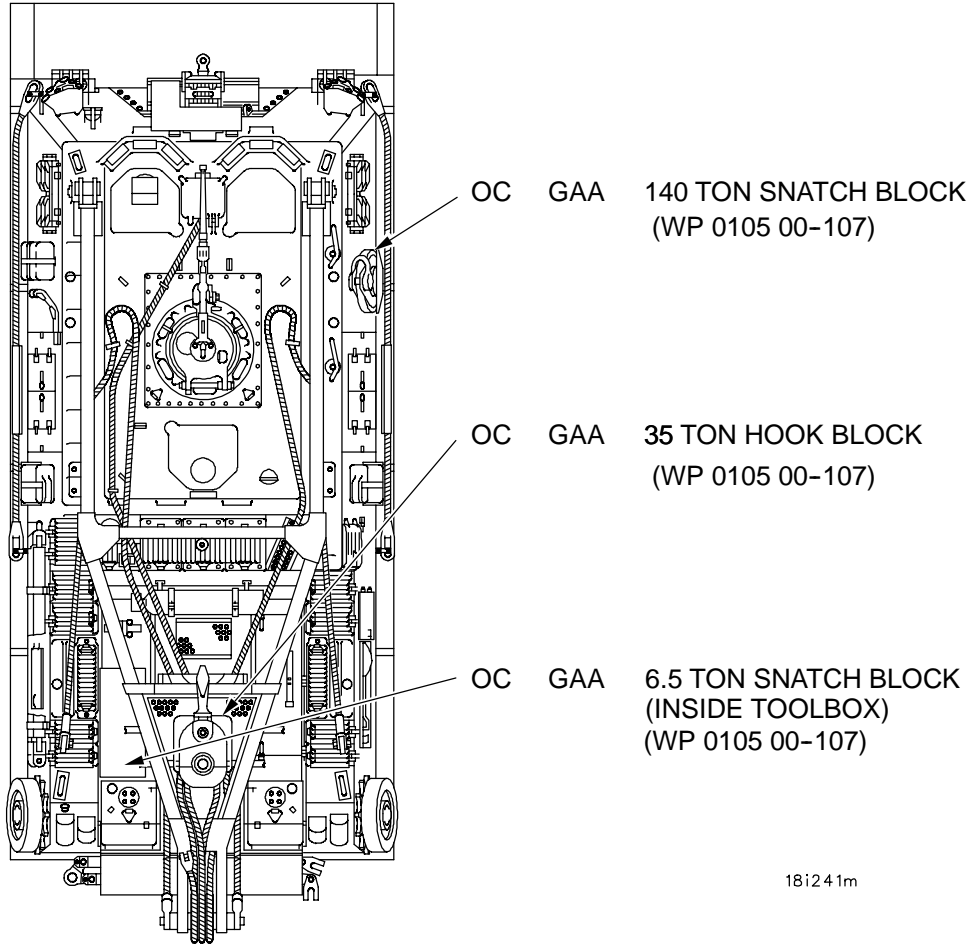

TOTAL MAN-HRS	
INTERVAL MAN-HRS	
OC	.5

**PREVENTIVE MAINTENANCE CHECKS AND SERVICES INCLUDING
LUBRICATION INSTRUCTIONS - CONTINUED**

0105 00

TABLE 6 LUBRICATION INSTRUCTIONS - CONTINUED

19. STEERING LINKAGE

Lubricate steering linkage with GAA through two fittings until grease is visible at bearing. Wipe excess grease with wiping rag (item 45, WP 0135 00).

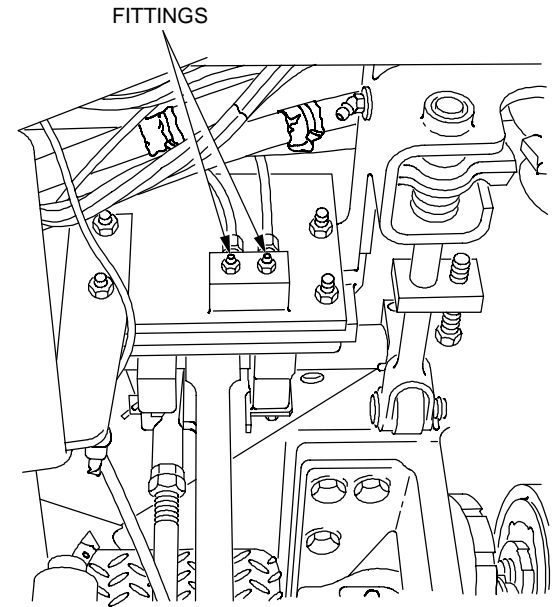

20. STEERING LINKAGE BELLCRANK

Lubricate bellcrank with GAA through fitting until grease is visible. Wipe excess grease with wiping rag (item 45, WP 0135 00).

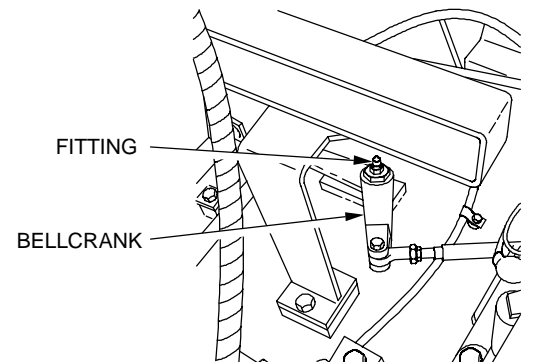

14i032m

**PREVENTIVE MAINTENANCE CHECKS AND SERVICES INCLUDING
LUBRICATION INSTRUCTIONS - CONTINUED**

0105 00

TABLE 6 LUBRICATION INSTRUCTIONS - CONTINUED

21. STEERING CONTROL ASSEMBLY

Lubricate steering control assembly with GAA through two fittings until grease is visible. Wipe excess grease with wiping rag (item 45, WP 0135 00).

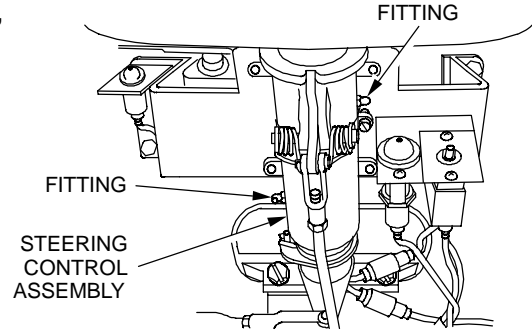

22. SERVICE BRAKE SHAFT

Lubricate shaft with GAA through two fittings (one fitting on each end of shaft) until grease is visible. Wipe excess grease with wiping rag (item 45, WP 0135 00).

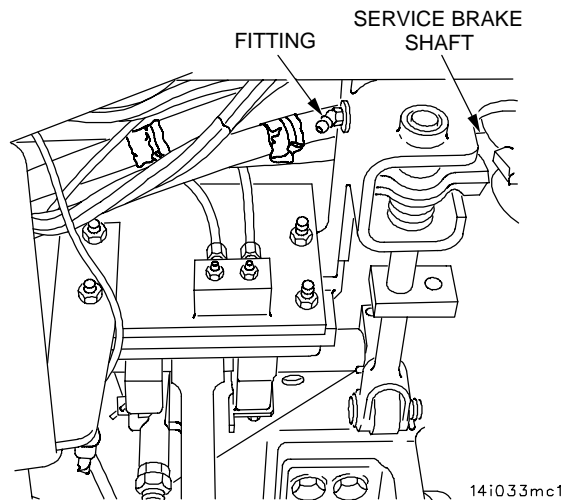

14i033mc1

**PREVENTIVE MAINTENANCE CHECKS AND SERVICES INCLUDING
LUBRICATION INSTRUCTIONS - CONTINUED**

0105 00

TABLE 6 LUBRICATION INSTRUCTIONS - CONTINUED

23. SERVICE BRAKE LINKAGE

Lubricate brake lever with GAA through fitting until grease is visible. Wipe excess grease with wiping rag (item 45, WP 0135 00). Remove subfloor access plate #11 (WP 0036 00). Lubricate two pillow blocks with GAA through two fittings until grease is visible. Wipe excess grease with wiping rag. Install subfloor access plate #11 (WP 0036 00).

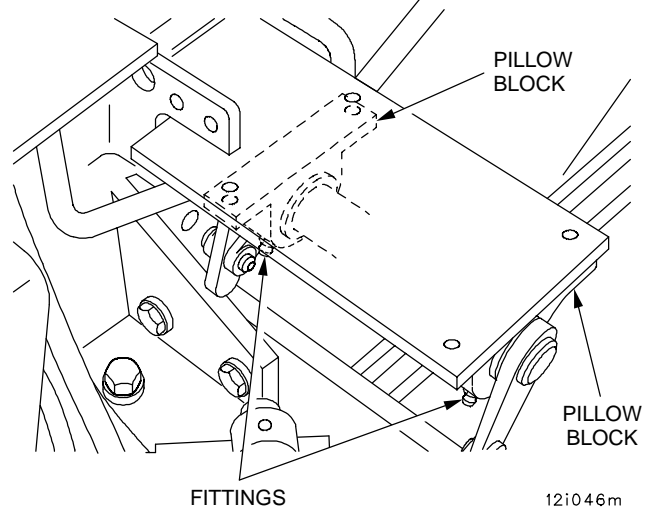
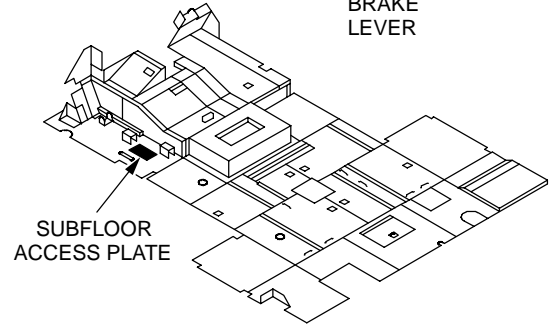
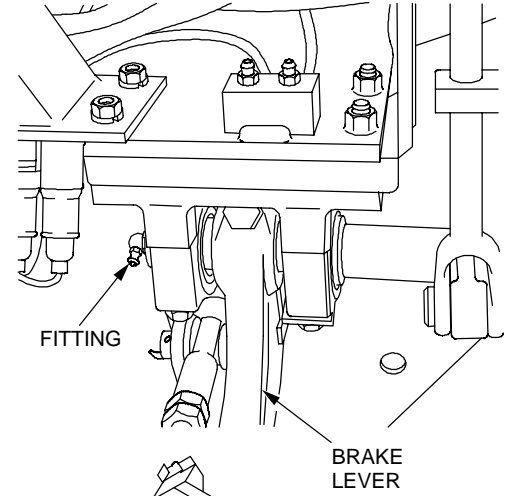

12i046m

**PREVENTIVE MAINTENANCE CHECKS AND SERVICES INCLUDING
LUBRICATION INSTRUCTIONS - CONTINUED**

0105 00

TABLE 6 LUBRICATION INSTRUCTIONS - CONTINUED

24. MAIN WINCH DIAMOND SCREW

Remove subfloor access plate #1 (WP 0036 00). Remove two thumbscrews and raise diamond screw cover. Lubricate diamond screw through two fittings with GAA until grease is visible. Operate main winch (WP 0050 00) to exercise diamond screw until a coating of grease is distributed evenly over the diamond screw. Repeat lubrication as required. Close diamond screw cover and secure with two thumbscrews. Install subfloor access plate #1 (WP 0036 00).

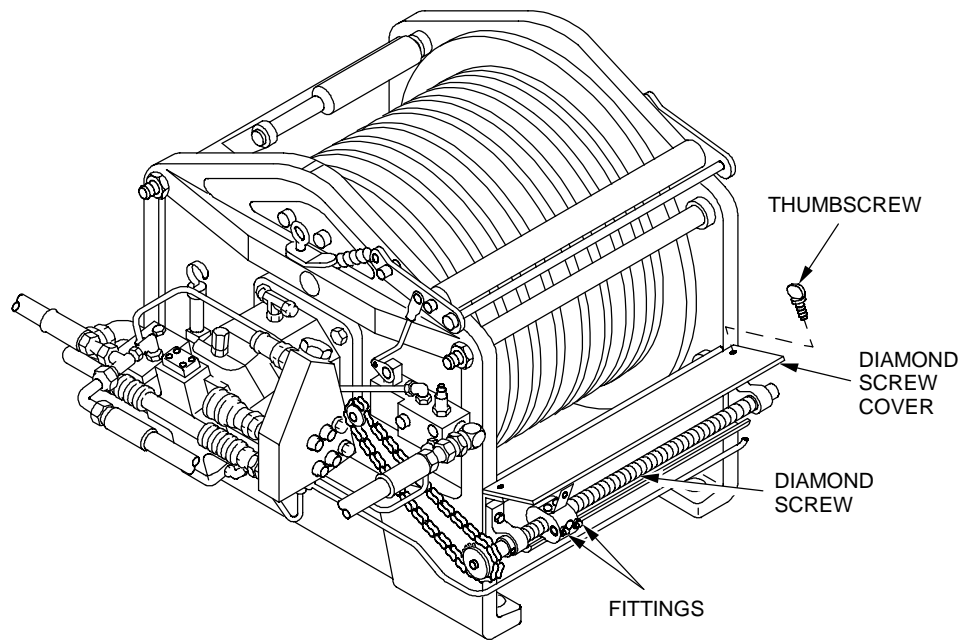
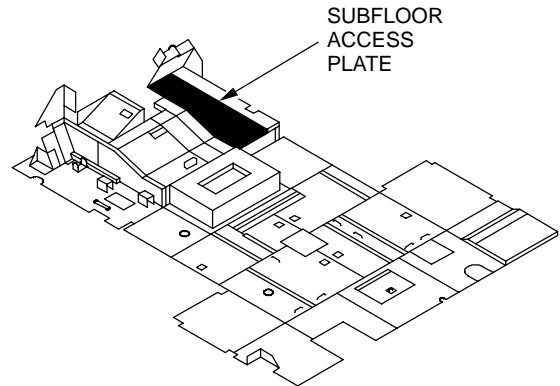

20i141m

PREVENTIVE MAINTENANCE CHECKS AND SERVICES INCLUDING LUBRICATION INSTRUCTIONS - CONTINUED

0105 00

TABLE 6 LUBRICATION INSTRUCTIONS - CONTINUED

25. COMPENSATING IDLER WHEELS AND ARMS

Open armor skirt panel #1 (WP 0106 00). Lubricate two compensating idler wheels with GAA through two fittings until safety relief valve opens. Lubricate two idler arm bearings with GAA through two fittings until grease is visible. Wipe excess grease with wiping rag (item 45, WP 0135 00). Close armor skirt panel (WP 0106 00).

ARMOR SKIRT
REMOVED FOR CLARITY

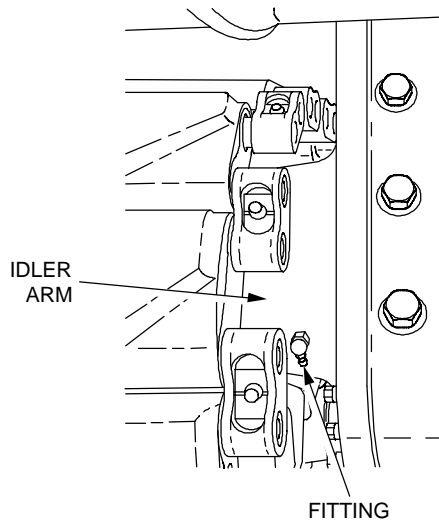
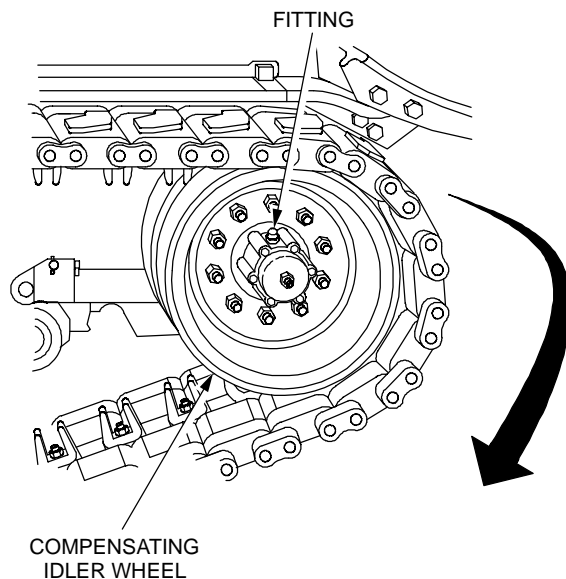

13i041m

PREVENTIVE MAINTENANCE CHECKS AND SERVICES INCLUDING LUBRICATION INSTRUCTIONS - CONTINUED

0105 00

TABLE 6 LUBRICATION INSTRUCTIONS - CONTINUED

26. ROADWHEEL HUB BEARINGS AND PIVOT ARM ASSEMBLY

Lubricate roadwheel hub bearings with GAA through 12 fittings (one on each roadwheel hub) until safety relief valve opens. Lubricate pivot arm assembly with GAA through 30 fittings until grease is visible. Wipe excess grease with wiping rag (item 45, WP 0135 00).

NOTE

Vehicle may be equipped with 20 lubrication fittings and ten pressure relief valves. If vehicle is so equipped perform the following step.

Lubricate pivot arm assembly through 20 lubrication fittings until grease escapes from pressure relief valve. Wipe excess with wiping rag (item 45, WP 0135 00).

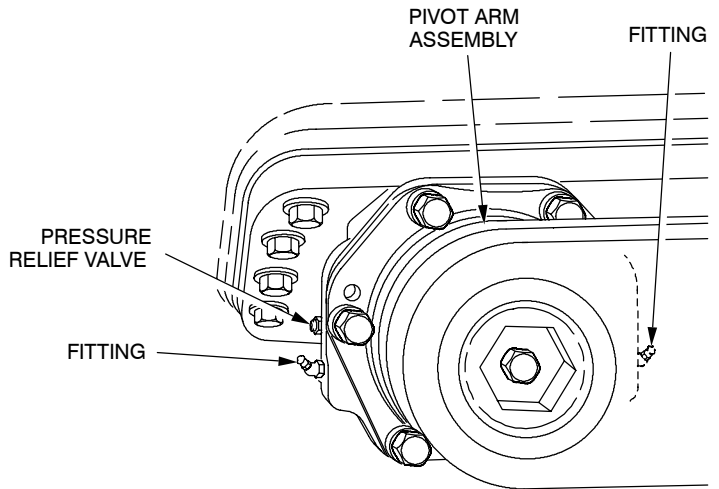
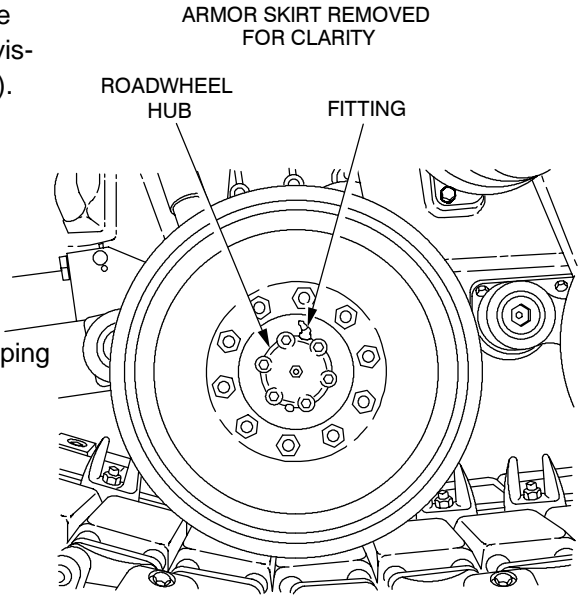

13i042m

**PREVENTIVE MAINTENANCE CHECKS AND SERVICES INCLUDING
LUBRICATION INSTRUCTIONS - CONTINUED**

0105 00

TABLE 6 LUBRICATION INSTRUCTIONS - CONTINUED

27. TRACK SUPPORT ROLLERS

Open armor skirt panels #2, #4 and #6 (WP 0106 00). Lubricate six track support rollers with GAA through six fittings until grease exits at seals (one fitting on each track support roller). Wipe excess grease with wiping rag (item 45, WP 0135 00). Close armor skirt panels #2, #4 and #6 (WP 0106 00).

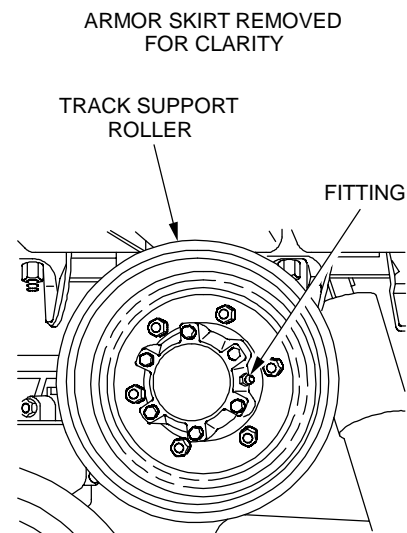
**28. TOWING PINTLE**

Lubricate towing pintle with GAA through three fittings until grease is visible. Wipe excess grease with wiping rag (item 45, WP 0135 00).

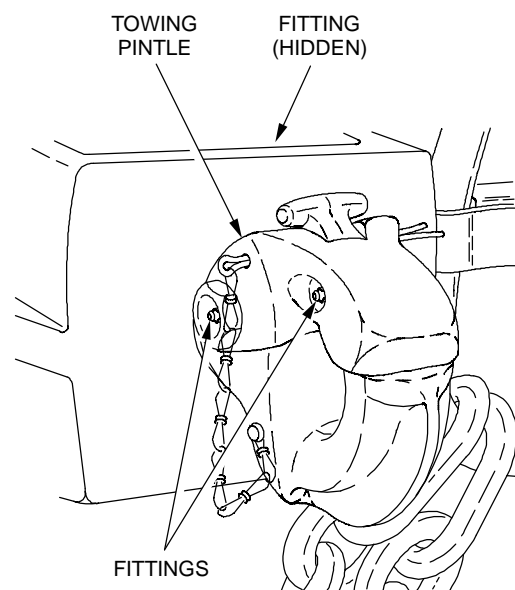

13i043m

**PREVENTIVE MAINTENANCE CHECKS AND SERVICES INCLUDING
LUBRICATION INSTRUCTIONS - CONTINUED**

0105 00

TABLE 6 LUBRICATION INSTRUCTIONS - CONTINUED

29. 35 TON HOOK BLOCK

Lubricate 35 ton hook block with GAA through fitting until grease is visible. Wipe excess grease with wiping rag (item 45, WP 0135 00).

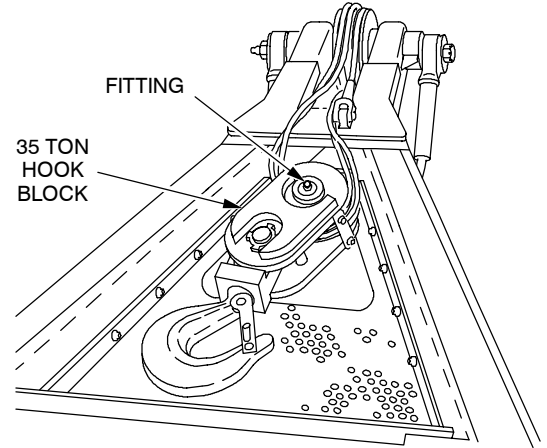

30. 140 TON SNATCH BLOCK

Remove pin from 140 ton snatch block and lubricate with GAA. Install pin in 140 ton snatch block. Lubricate 140 ton snatch block through fitting until grease is visible. Wipe off excess grease with wiping rag (item 45, WP 0135 00).

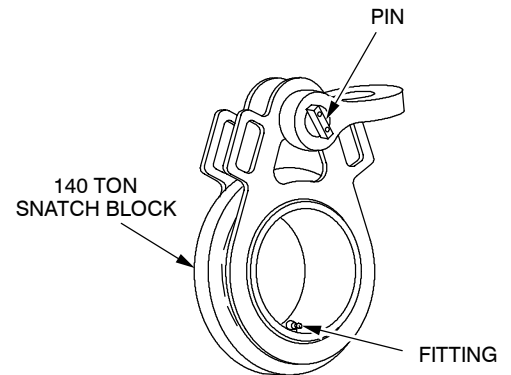

31. 6.5 TON SNATCH BLOCK

Remove two pins from 6.5 ton snatch block and lubricate two pins with GAA. Install two pins in 6.5 ton snatch block. Wipe off excess grease with wiping rag (item 45, WP 0135 00).

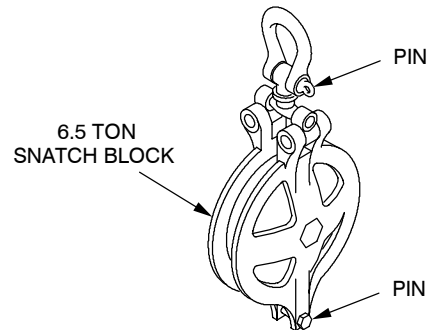

18i242m

**PREVENTIVE MAINTENANCE CHECKS AND SERVICES INCLUDING
LUBRICATION INSTRUCTIONS - CONTINUED**

0105 00

TABLE 6 LUBRICATION INSTRUCTIONS - CONTINUED

OIL CAN POINTS

Lubricate monthly or on condition with PL-S. Clean lubrication points before lubricating. Wipe off excess lubricant with wiping rag (item 45, WP 0135 00).

**LEFT SIDE STOWAGE
DOOR LATCH AND HINGES**

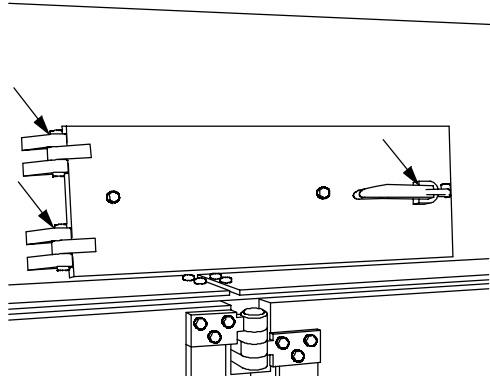

**LEFT/RIGHT SIDE PERSONNEL DOOR
LATCH (EXTERIOR)**

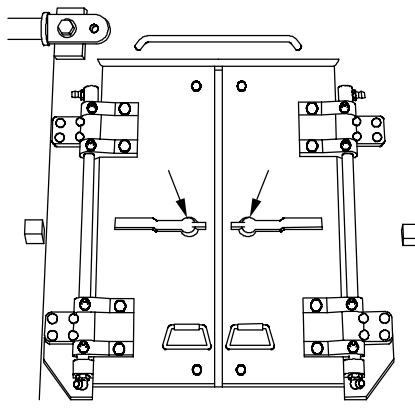

18i039mb

**APU ACCESS AND
RIGHTSIDE STOWAGE
DOOR LATCHES AND
HINGES**

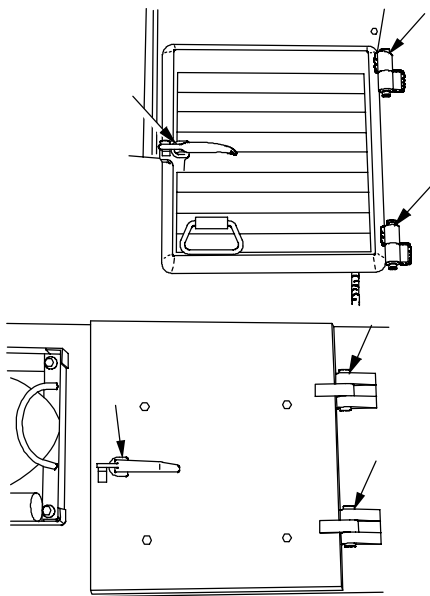

**LEFT/RIGHT SIDE PERSONNEL DOOR
LOCKPINS AND LATCH MECHANISM**

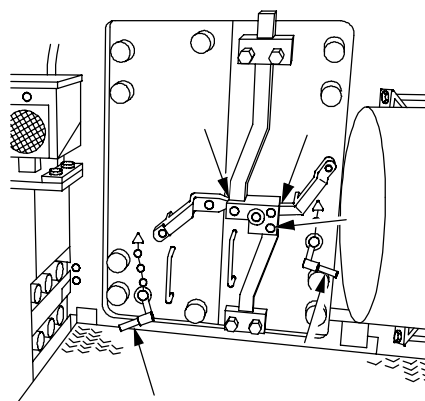

**HYDRAULIC COMPARTMENT
ACCESS DOOR LATCHES AND
HINGES**

TABLE 6 LUBRICATION INSTRUCTIONS - CONTINUED

OIL CAN POINTS

Lubricate monthly or on condition with PL-S. Clean lubrication points before lubricating. Wipe off excess lubricant with wiping rag (item 45, WP 0135 00).

**ENGINE DECK DOOR HINGES,
LATCHES AND RETAINING BOLTS**

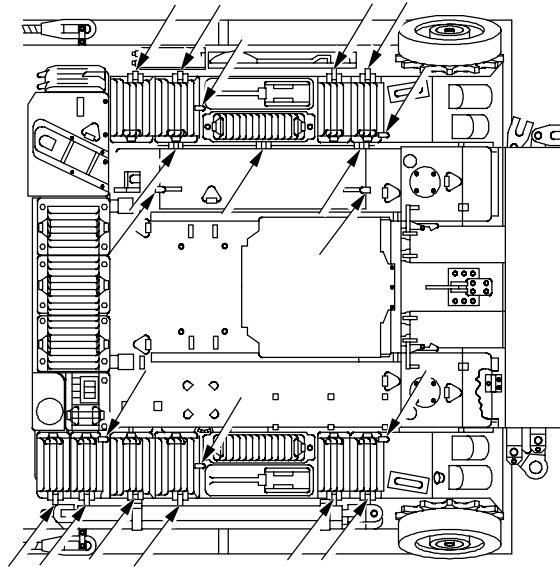

18i034m

**EXHAUST DEFLECTOR PIVOT
PIN AND HINGES**

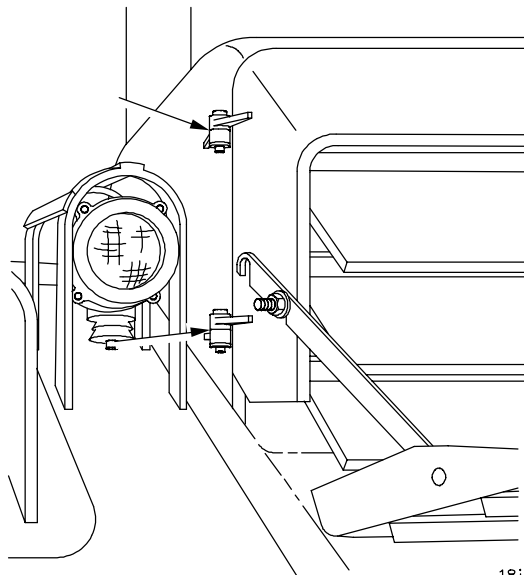

18i029m

**PREVENTIVE MAINTENANCE CHECKS AND SERVICES INCLUDING
LUBRICATION INSTRUCTIONS - CONTINUED**

0105 00

TABLE 6 LUBRICATION INSTRUCTIONS - CONTINUED

OIL CAN POINTS

Lubricate monthly or on condition with PL-S. Clean lubrication points before lubricating. Wipe off excess lubricant with wiping rag (item 45, WP 0135 00).

WISE

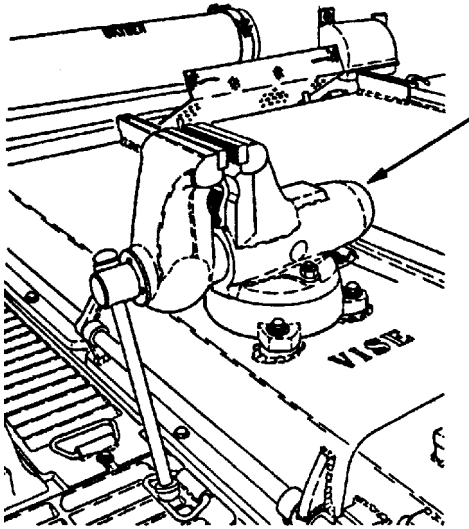

18i030ma

BOOM LIMIT VALVE ACTUATING
ARM SHAFT (LEFT/RIGHT SIDE)

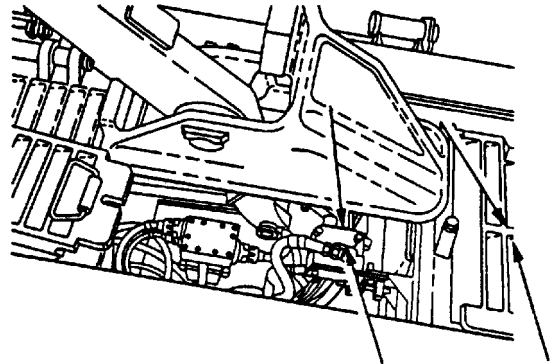

18i025mb

BOOM LOCKPIN

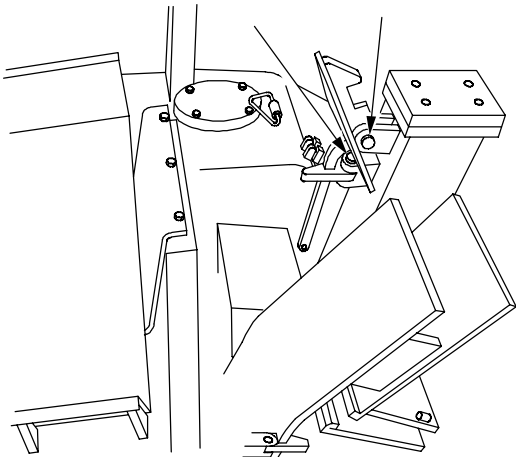

18i030m

CAL. .50 MACHINE GUN
MOUNT TRAVERSE LOCK

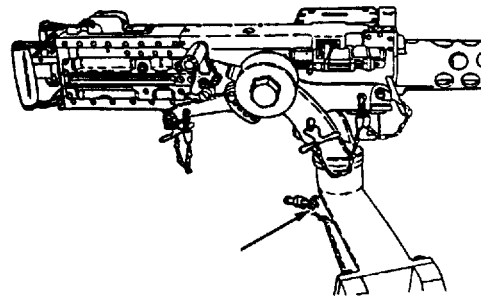

18i259m

**PREVENTIVE MAINTENANCE CHECKS AND SERVICES INCLUDING
LUBRICATION INSTRUCTIONS - CONTINUED**

0105 00

TABLE 6 LUBRICATION INSTRUCTIONS - CONTINUED

OIL CAN POINTS

Lubricate monthly or on condition with PL-S. Clean lubrication points before lubricating. Wipe off excess lubricant with wiping rag (item 45, WP 0135 00).

ON-VEHICLE STOWAGE
CLAMPS (LEFT/RIGHT SIDE)

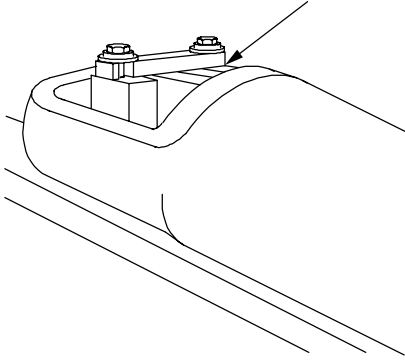

ON-VEHICLE STOWAGE
CLAMPS

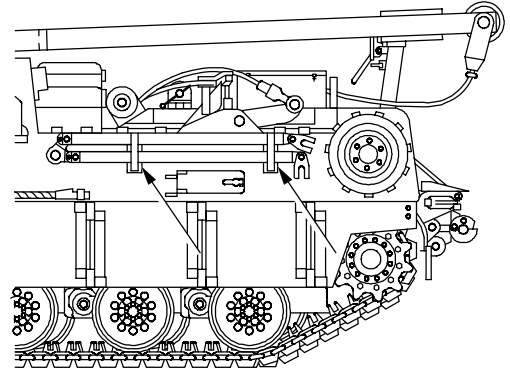

SIDE ARMOR SKIRTS HINGE
PINS (LEFT/RIGHT SIDE)

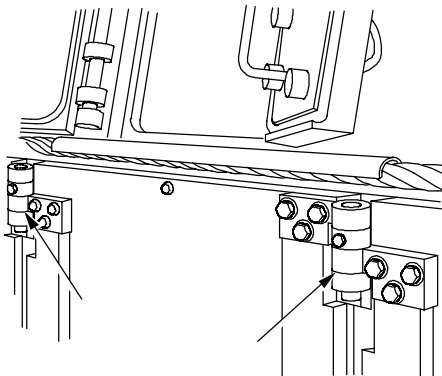

PIVOT PINS

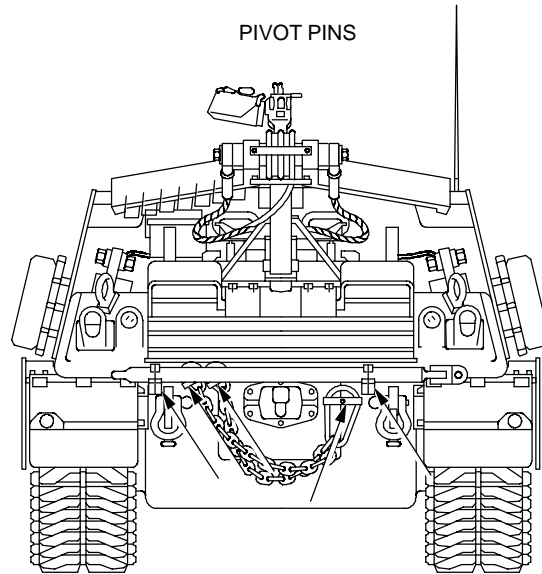

18i032ma

**PREVENTIVE MAINTENANCE CHECKS AND SERVICES INCLUDING
LUBRICATION INSTRUCTIONS - CONTINUED**

0105 00

TABLE 6 LUBRICATION INSTRUCTIONS - CONTINUED

OIL CAN POINTS

Lubricate monthly or on condition with PL-S. Clean lubrication points before lubricating. Wipe off excess lubricant with wiping rag (item 45, WP 0135 00).

**REAR FENDER HINGES
(LEFT/RIGHT SIDES)**

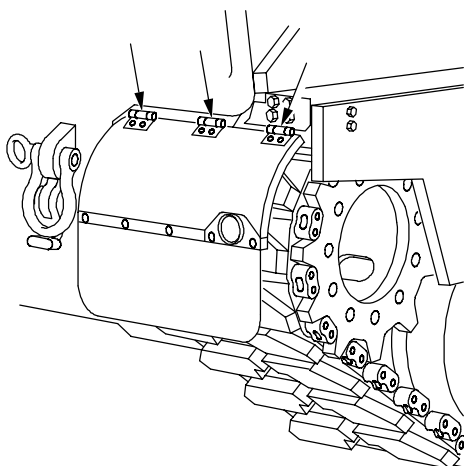

**140-TON SNATCH BLOCK
RETAINING BAR PINS**

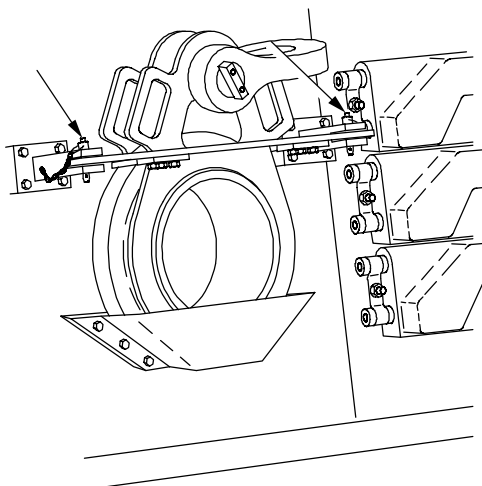

**HEADLAMP REMOVAL
NUT (LEFT/RIGHT SIDES)**

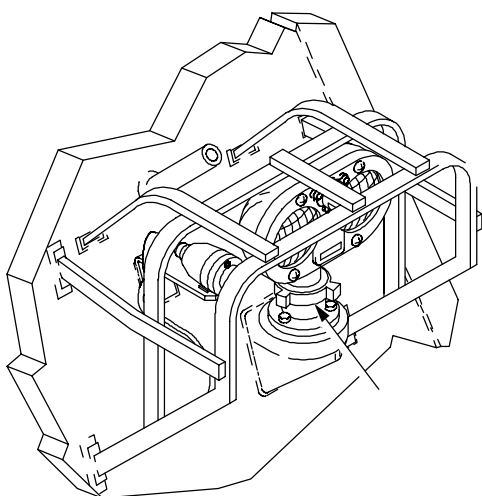

**MANUAL FUEL SHUTOFF
LINKAGE**

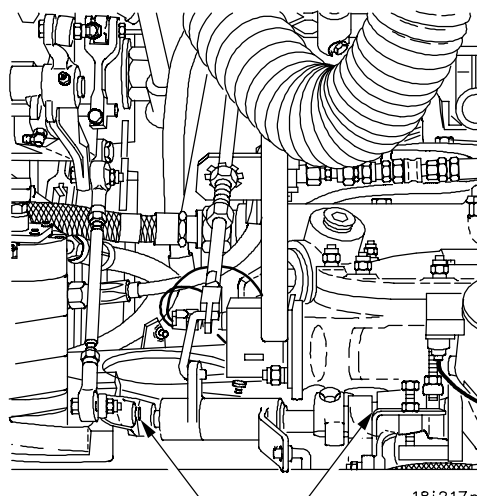

18i217m

PREVENTIVE MAINTENANCE CHECKS AND SERVICES INCLUDING LUBRICATION INSTRUCTIONS - CONTINUED

0105 00

TABLE 6 LUBRICATION INSTRUCTIONS - CONTINUED

OIL CAN POINTS

Lubricate monthly or on condition with PL-S. Clean lubrication points before lubricating. Wipe off excess lubricant with wiping rag (item 45, WP 0135 00).

DRIVER'S, MECHANIC'S, AND COMMANDER'S SEAT MOVING PARTS

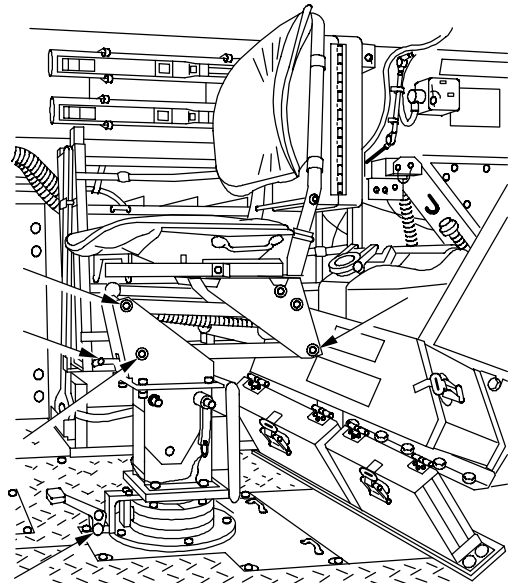
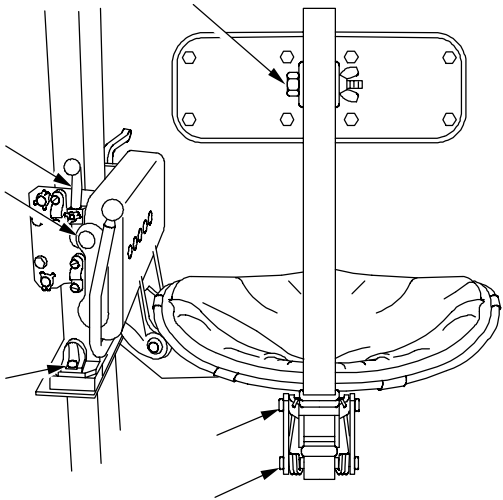

SUBFLOOR ACCESS PLATE HINGES

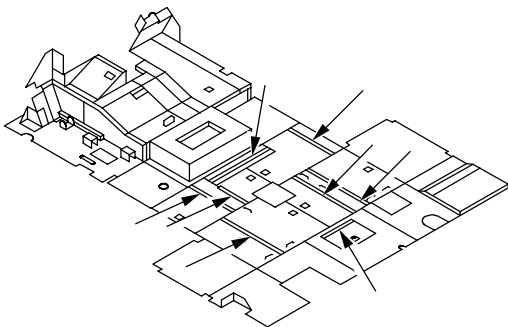

COMMANDER'S CUPOLA

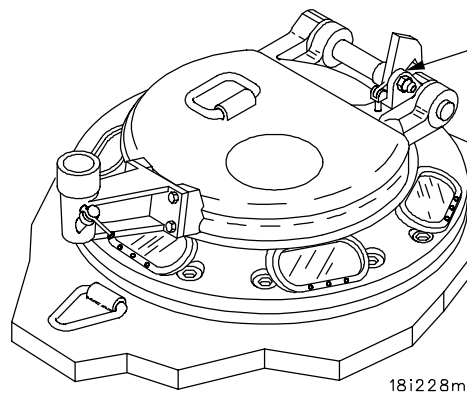

18i228m

END OF TASK

OPENING, REMOVAL, INSTALLATION AND CLOSING OF ARMOR SKIRT PANELS

0106 00

THIS WORK PACKAGE COVERS:

Opening, Removal, Installation, Closing

INITIAL SETUP:

Tools and Special Tools

- Adjustable wrench (item 40, Table 2, WP 0133 00)
- Driftpin (item 11, Table 2, WP 0133 00)
- Hammer (item 18, Table 2, WP 0133 00)
- Auxiliary boom (item 1, Table 1, WP 0133 00) (For removal and installation of panel)
- Chain hoist (item 8, Table 1, WP 0133 00)

Personnel Required

Three

References

- WP 0133 00
- WP 0039 00
- WP 0019 00

Equipment Conditions

Vehicle parked and engine shut down (WP 0019 00)



Do not drive vehicle unless skirts are secured in the closed position with hinge pins in place. Failure to comply may result in panel swinging and causing damage.

OPENING ARMOR SKIRT PANELS

Panels #1 and #8:

NOTE

Skirt panel #1 may be equipped with foot step.

1. Remove two bolts (1) and two flat washers (2) securing skirt panel against stop.
2. Open panel by hand.

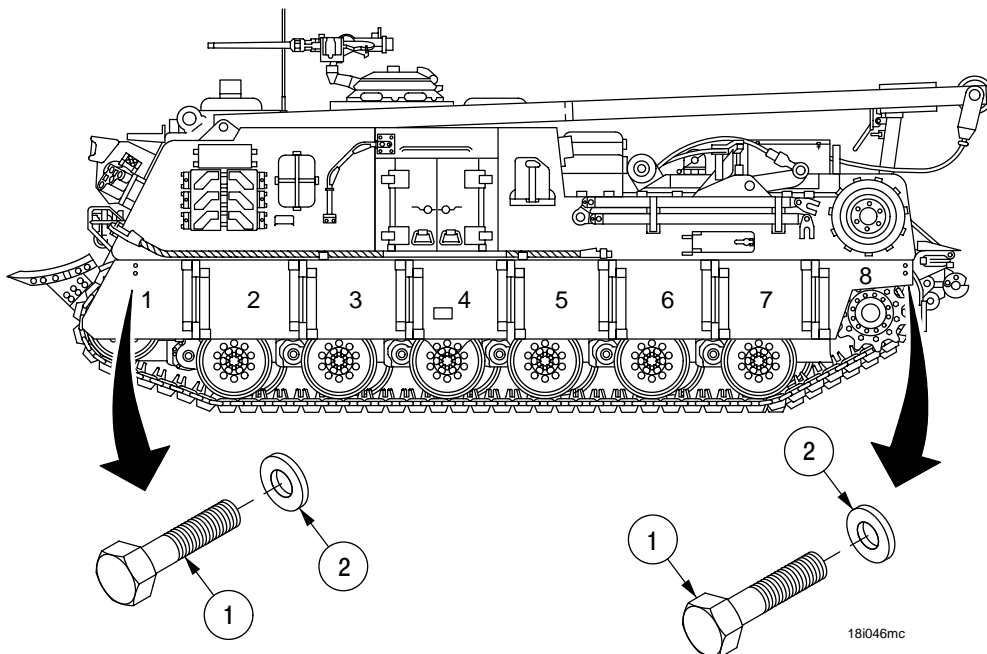

**OPENING, REMOVAL, INSTALLATION AND CLOSING OF ARMOR SKIRT
PANELS - CONTINUED**

0106 00

OPENING ARMOR SKIRT PANELS - CONTINUED**Panels #2 through #7:**

1. Remove two screws (3) from two stand-offs (4) and two hinge pins (5).

CAUTION

Do not use steel hammer or punch when removing hinge pins. Metal to metal contact will mushroom hinge pin making it impossible to remove pin. Failure to comply may result in damage to equipment.

2. Using brass drift punch and hammer, remove two hinge pins (5) from two panel hinges (6) and two standoffs (4).
3. Swing panels open by hand.

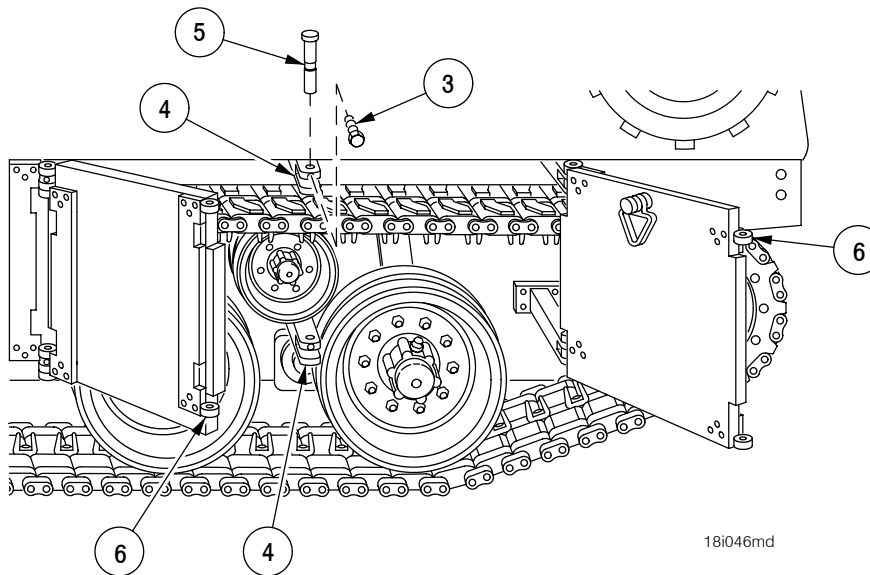

OPENING, REMOVAL, INSTALLATION AND CLOSING OF ARMOR SKIRT PANELS - CONTINUED

0106 00

REMOVE ARMOR SKIRT PANELS FROM VEHICLE

NOTE

The removal procedure for all armor skirts are the same except for the location of the auxiliary boom.

1. Open panels in accordance with this work package.
2. Assemble auxiliary boom (WP 0039 00) and attach to D-ring (7) located inside each skirt panel.
3. Using chain hoist, lift weight of the panel hinges (6) off of two stand-offs (4), remove two screws (3) from two stand-offs (4) and two hinge pins (5).
4. Using a brass drift punch and hammer, remove two hinge pins (5).
5. Pull skirt panel away from two stand-offs (4) and lower skirt panel to ground. Disconnect chain hoist.

INSTALLATION OF ARMOR SKIRT PANELS



Do not drive vehicle unless skirts are secured in the closed position with hinge pins in place. Failure to comply may result in panel swinging and causing damage.

NOTE

The installation procedures for all armor skirts are the same except for the location of the auxiliary boom.

1. Assemble auxiliary boom (WP 0039 00) and attach to D-ring (7) located inside each armor skirt panel.
2. Using chain hoist, lift and position armor skirt panel onto two stand-offs (4), aligning mounting holes. Install two hinge pins (5) into two panel hinges (6) and two stand-offs (4).

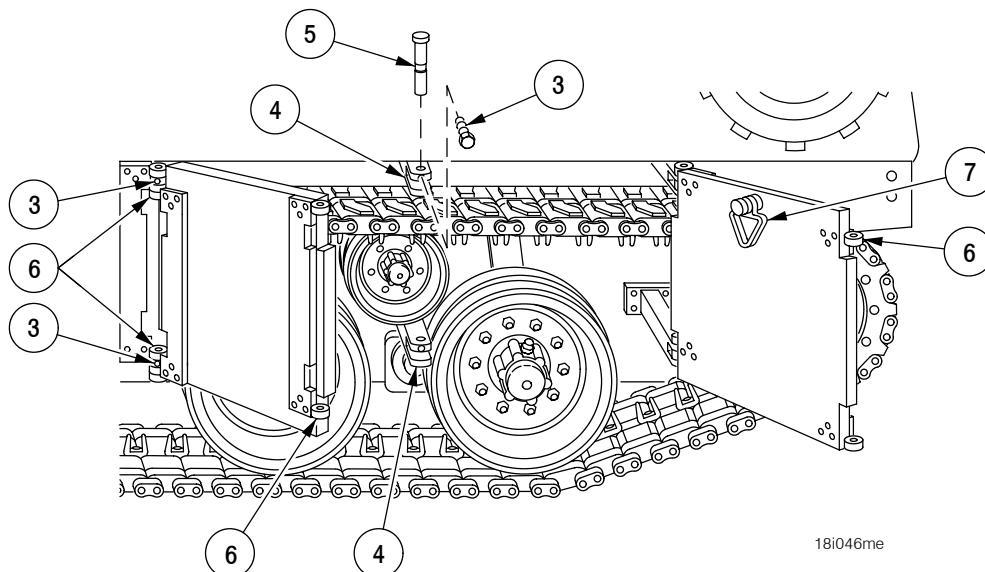

18i046me

OPENING, REMOVAL, INSTALLATION AND CLOSING OF ARMOR SKIRT PANELS - CONTINUED

0106 00

INSTALLATION OF ARMOR SKIRT PANELS - CONTINUED

3. Install two screws (3) into two stand-offs (4) to secure two hinge pins (5). Disconnect chain hoist, and stow.

CLOSING ARMOR SKIRT PANELS

Panels #2 through #7.

CAUTION

Do not use steel hammer or punch when installing hinge pins. Metal to metal contact will mushroom hinge pin making it impossible to remove pin. Failure to comply may result in damage to equipment.

1. Close panel against stand-offs.
2. Using hammer and brass drift, install two hinge pins (5) into two panel hinges (6) and two stand-offs (4).
3. Install two screws (3) into two stand-offs (4) to secure hinge pins (5).

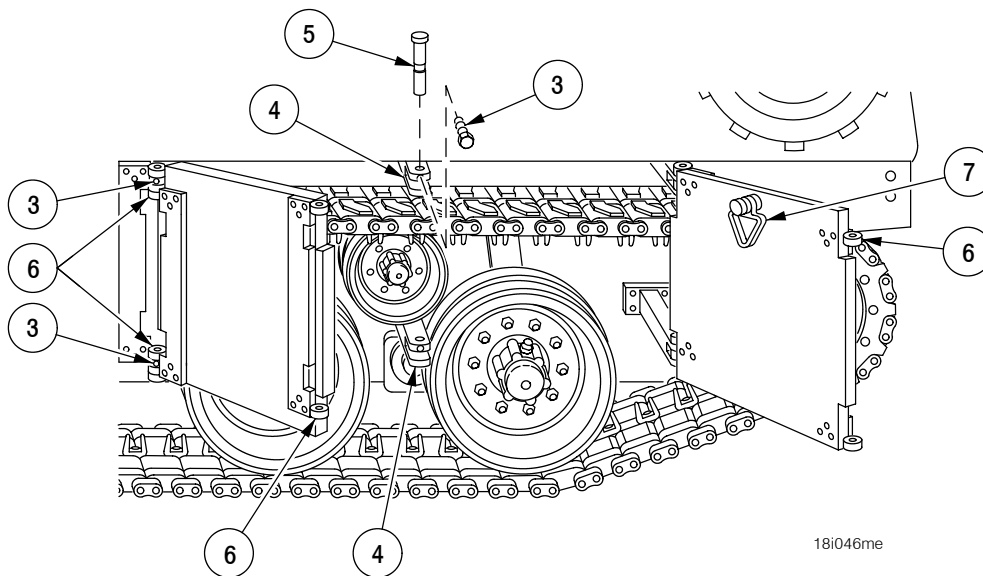

18i046me

**OPENING, REMOVAL, INSTALLATION AND CLOSING OF ARMOR SKIRT
PANELS - CONTINUED****0106 00****CLOSING ARMOR SKIRT PANELS - CONTINUED**

Panels #1 and #8.

NOTE

Skirt panel #1 may be equipped with a foot step.

1. Close panel against stop.
2. Install two flat washers (2) and two bolts (1).

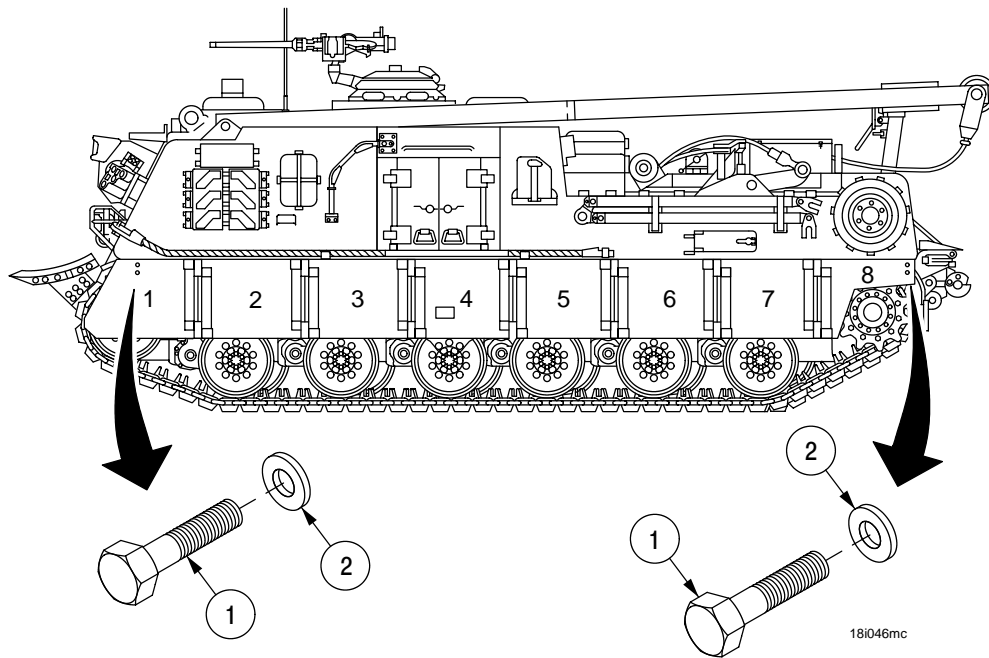
**END OF TASK**

OPENING, REMOVAL, INSTALLATION AND CLOSING OF ARMOR SKIRT PANELS WITH QUICK-RELEASE PIN

0107 00

THIS WORK PACKAGE COVERS:

Opening, Removal, Installation, Closing

INITIAL SETUP:

Tools and Special Tools

- Adjustable wrench (item 40, Table 2, WP 0133 00)
- Driftpin (item 11, Table 2, WP 0133 00)
- Hammer (item 18, Table 2, WP 0133 00)
- Auxiliary boom (item 1, Table 1, WP 0133 00) (For Removal and Installation of panel)
- Chain hoist (item 8, Table 1, WP 0133 00)

Personnel Required

Three

References

- WP 0133 00
- WP 0039 00
- WP 0019 00

Equipment Conditions

Vehicle parked and engine shut down (WP 0019 00)



Do not drive vehicle unless skirts are secured in the closed position with hinge pins in place. Failure to comply may result in panel swinging and causing damage.

OPENING ARMOR SKIRT PANELS

Panels #1, #4, #5 and #8:

1. Remove pin assembly (1) from straight headed pin (2).
2. Remove straight headed pin (2) securing skirt panel against stop (3).
3. Open panel by hand.

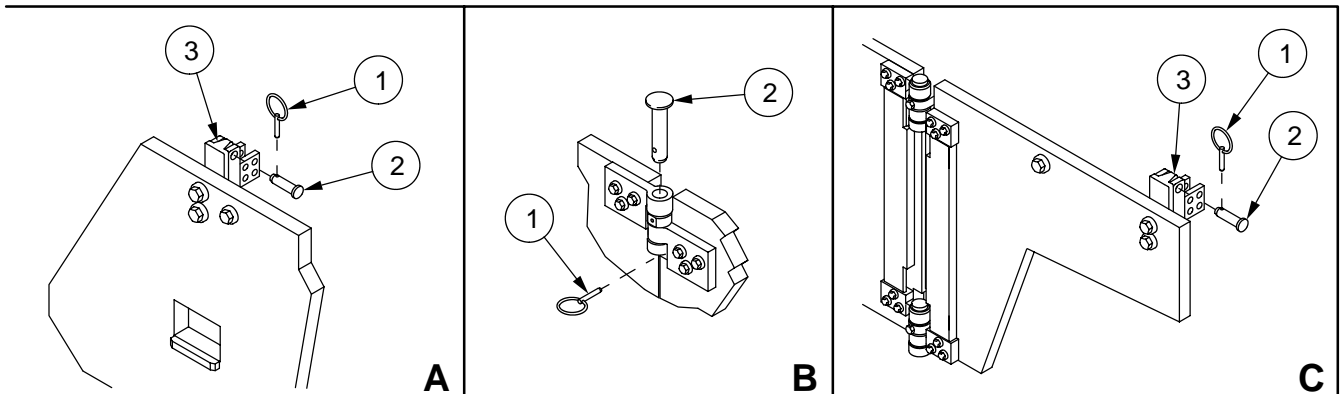
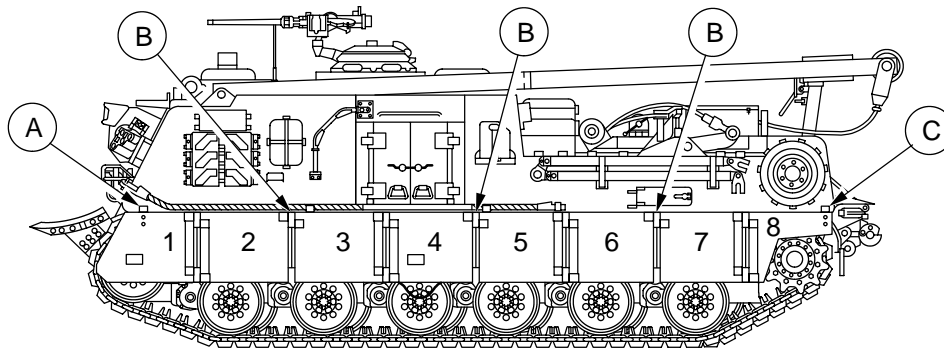

18i368m

**OPENING, REMOVAL, INSTALLATION AND CLOSING OF ARMOR SKIRT
PANELS WITH QUICK-RELEASE PIN - CONTINUED****0107 00****OPENING ARMOR SKIRT PANELS - CONTINUED****Panels #2, #3, #6 and #7:**

1. Remove two screws (4) from two stand-offs (5) and two hinge pins (6).

CAUTION

Do not use steel hammer or punch when removing hinge pins. Metal to metal contact will mushroom hinge pin making it impossible to remove pin. Failure to comply may result in damage to equipment.

2. Using brass drift punch and hammer, remove two hinge pins (6) from two panel hinges (7) and two standoffs (5).
3. Swing panels open by hand.

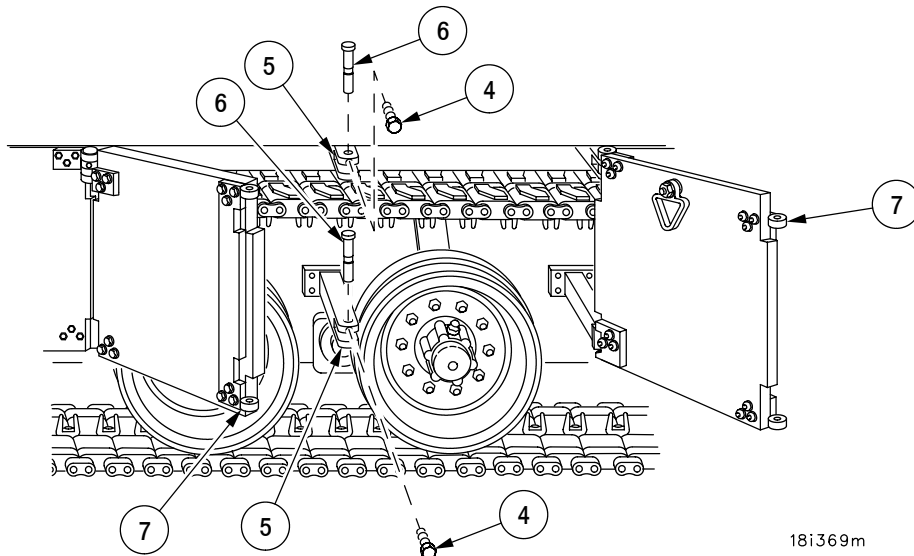

18i369m

OPENING, REMOVAL, INSTALLATION AND CLOSING OF ARMOR SKIRT PANELS WITH QUICK-RELEASE PIN - CONTINUED

0107 00

REMOVAL OF ARMOR SKIRT PANELS FROM VEHICLE

NOTE

The removal procedure for all armor skirts is the same except for the location of the auxiliary boom.

1. Open panels in accordance with this work package.
2. Assemble auxiliary boom (WP 0039 00) and attach to D-ring (8) located inside each skirt panel.
3. Using chain hoist, lift weight of the panel hinges (7) off of two stand-offs (5), remove two screws (4) from two stand-offs (5) and two hinge pins (6).
4. Using a brass drift punch and hammer, remove two hinge pins (6).
5. Pull skirt panel away from two stand-offs (5) and lower skirt panel to ground. Disconnect chain hoist.

INSTALLATION OF ARMOR SKIRT PANELS



Do not drive vehicle unless skirts are secured in the closed position with hinge pins in place. Failure to comply may result in panel swinging and causing damage.

NOTE

The installation procedure for all armor skirts is the same except for the location of the auxiliary boom.

1. Assemble auxiliary boom (WP 0039 00), and attach to D-ring (8) located inside each armor skirt panel.
2. Using chain hoist, lift and position armor skirt panel onto two stand-offs (5), aligning mounting holes. Install two hinge pins (6) into two panel hinges (7) and two stand-offs (5).
3. Install two screws (4) into two stand-offs (5) to secure two hinge pins (6). Disconnect and stow chain hoist.

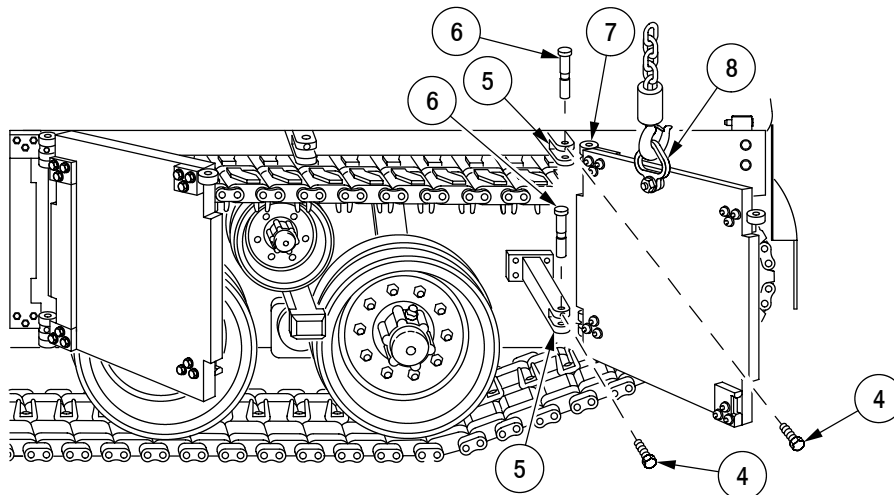

18i370m

**OPENING, REMOVAL, INSTALLATION AND CLOSING OF ARMOR SKIRT
PANELS WITH QUICK-RELEASE PIN - CONTINUED****0107 00****CLOSING ARMOR SKIRT PANELS**

Panels #2, #3, #6 and #7:

CAUTION

Do not use steel hammer or punch when installing hinge pins. Metal to metal contact will mushroom hinge pin making it impossible to remove pin. Failure to comply may result in damage to equipment.

1. Close panel against stand-offs.
2. Using hammer and brass drift, install two hinge pins (6) into two panel hinges (7) and two stand-offs (5).
3. Install two screws (4) into two stand-offs (5) to secure hinge pins (6).

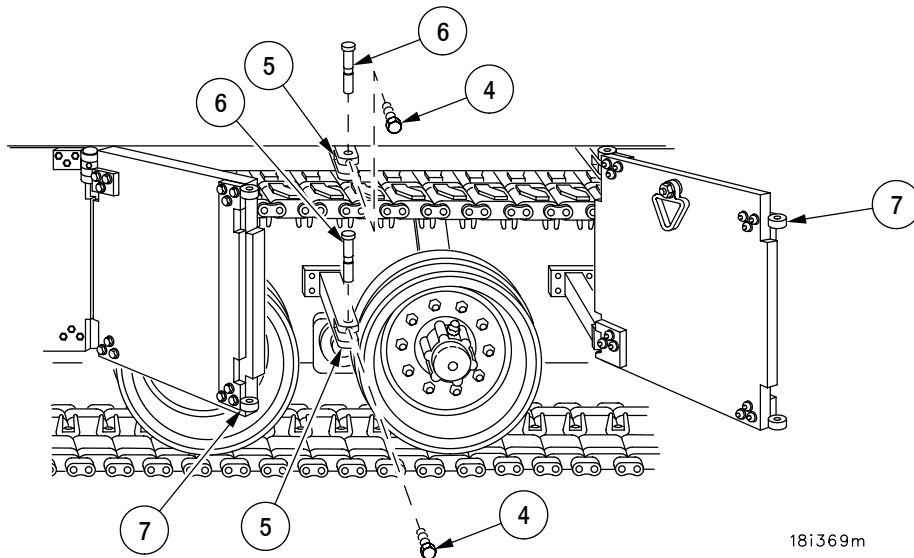

18i369m

**OPENING, REMOVAL, INSTALLATION AND CLOSING OF ARMOR SKIRT
PANELS WITH QUICK-RELEASE PIN - CONTINUED**

0107 00

CLOSING ARMOR SKIRT PANELS - CONTINUED

Panels #1, #4, #5 and #8:

1. Close panel against stop (3).
2. Install straight headed pin (2) securing panel against stop (3).
3. Install pin assembly (1) in straight headed pin (2).

NOTE

Skirt panel #1 may not be equipped with a foot step.

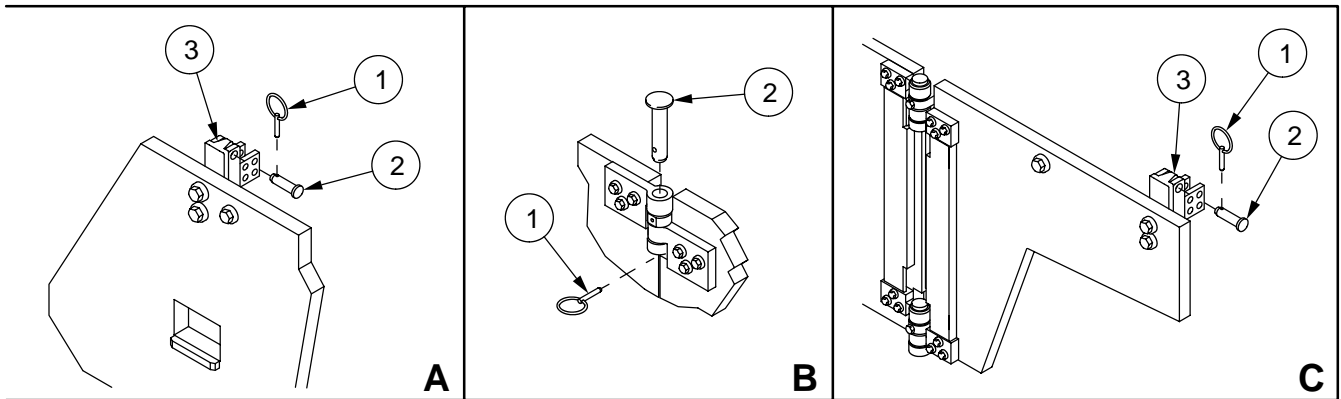
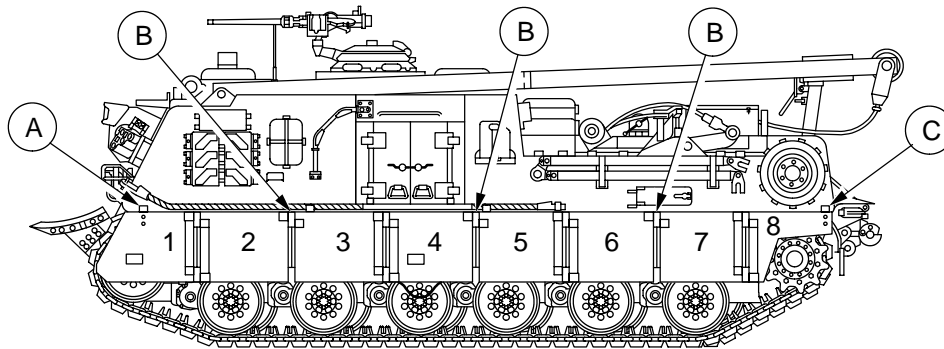

18i368m

END OF TASK

TRACK TENSION ADJUSTMENT (OLD CONFIGURATION)**0108 00****THIS WORK PACKAGE COVERS:**

Adjustment

INITIAL SETUP:**Tools and Special Tools**

Wire brush
 Grease gun adapter (item 2, Table 2, WP 0133 00)
 Grease gun (item 17, Table 2, WP 0133 00)
 Adjustable wrench (item 40, Table 2, WP 0133 00)
 Spanner wrench (item 44, Table 2, WP 0133 00)
 Screwdriver (item 30, Table 2, WP 0133 00)

Personnel Required

Three

References

WP 0135 00
 WP 0106 00
 WP 0019 00
 WP 0133 00
 WP 0113 00

Materials/Parts

Rags, wiping (item 45, WP 0135 00)
 Grease (item 16, WP 0135 00)

1. Move vehicle back and forth two or three times over hard, level ground. Coast to a stop and stop engine (WP 0019 00).
2. Open armor skirt panels #1 through #7 (WP 0106 00).
3. Using wire brush, clean threads (1) on track adjusting link (2).
4. Using wiping rag (item 45, WP 0135 00), clean relief valve (3) and grease fitting (4).
5. Connect grease gun adapter (item 2, Table 2, WP 0133 00) (5) to grease fitting (4).

WARNING

Grease will be under pressure. Personnel must wear goggles. Failure to comply may result in eye injury to personnel.

6. Using grease gun (item 17, Table 2, WP 0133 00), pump small amount of grease (item 16, WP 0135 00) into adjusting link (2) to release locknut (6).

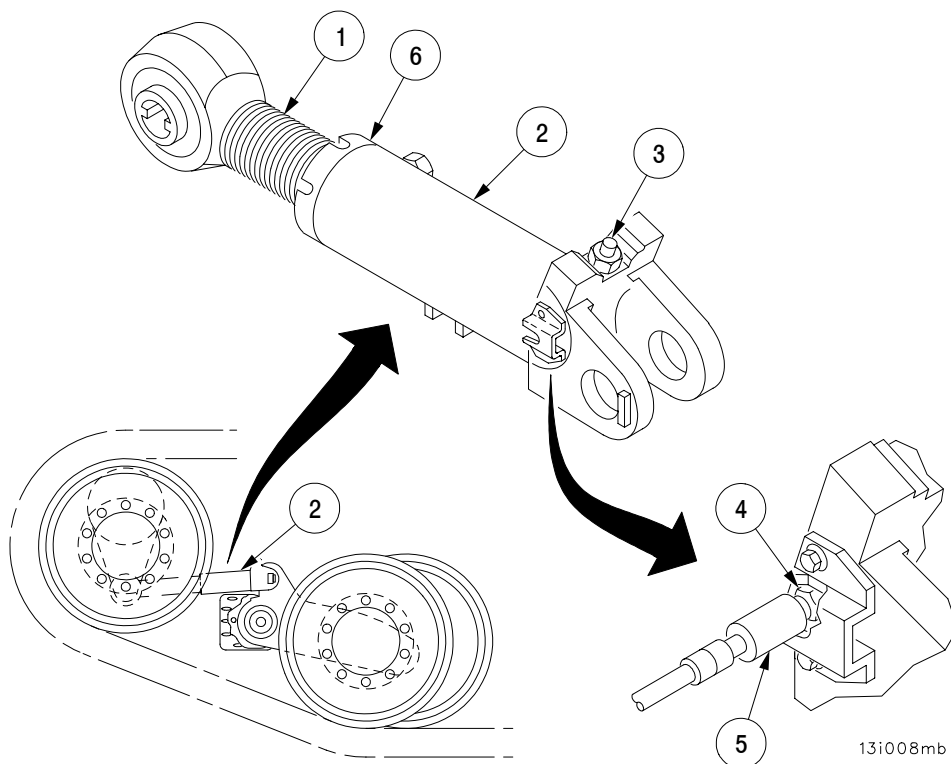

NOTE

- If grease fitting will not take grease or continues to leak grease after one minute, replace grease fitting.
- If relief valve works too easily, or if track adjusting link will not move, notify unit maintenance.
- If grease under pressure comes out of valve at bottom of cylinder during adjustment, track adjusting link is extended too far. Remove one track shoe (WP 0113 00) to shorten track and repeat track adjustment procedure.
- As track adjusting link moves, turn locknut to keep it close to cylinder assembly.
- Removing a shoe from one track does not require removing a shoe from other track.

7. Loosen locking screw (7) about 3 1/2 turns.

8. Back off locknut (6) using spanner wrench.

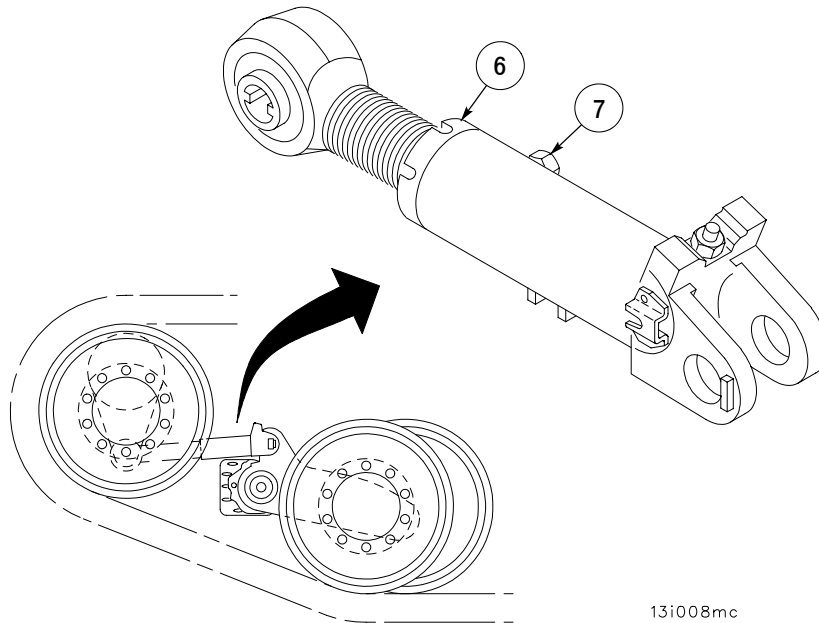

13i008mc

TRACK TENSION ADJUSTMENT (OLD CONFIGURATION) - CONTINUED

0108 00

9. Pump grease into track adjusting link grease fitting (4).
10. Stop pumping grease when grease flows from relief valve (3).
11. Tighten track adjusting link locknut (6).

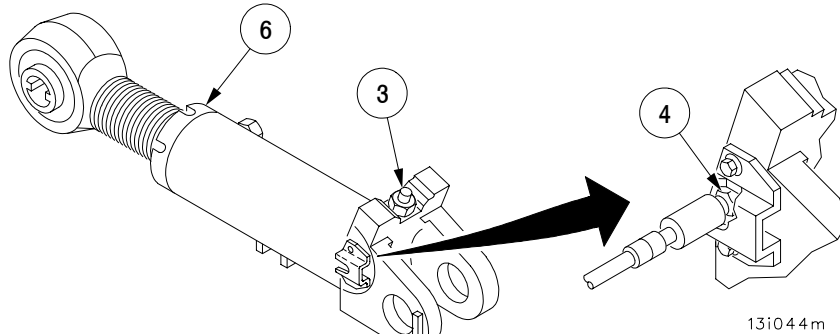

12. Disconnect grease gun adapter (5) from grease fitting (4).
13. Repeat steps 1 through 12 for other side of vehicle.
14. Alternately repeat steps 1 through 13 two more times for a total of three times for each side of vehicle.
15. Using spanner wrench, align nearest slot in locknut (6) with locking screw (7). Tighten locking screw (7) on track adjusting link (2).
16. Using a screwdriver, lift up and hold valve pin (8), so grease flows out.
17. Catch grease in wiping rags.
18. Let valve pin (8) go when grease stops flowing.
19. Close and secure armor skirt panels #1 through #7 (WP 0106 00).
20. Repeat steps 15 through 19 for other side of vehicle.

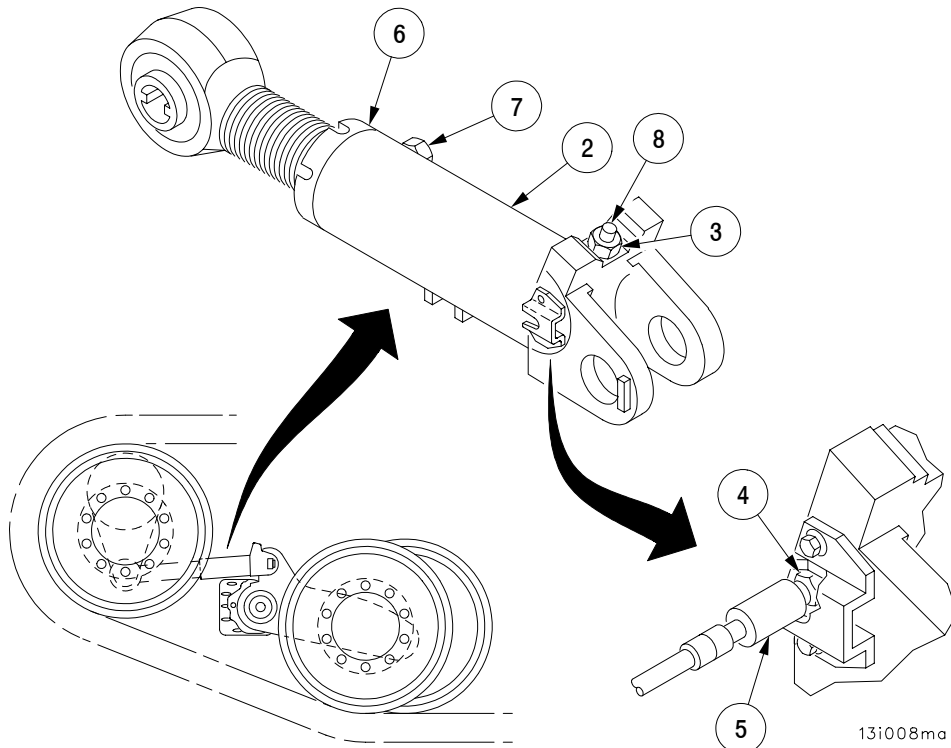

END OF TASK

TRACK TENSION ADJUSTMENT (NEW CONFIGURATION)

0109 00

THIS WORK PACKAGE COVERS:

Adjustment

INITIAL SETUP:

Tools and Special Tools

- Wire brush
- Grease gun adapter (item 2, Table 2, WP 0133 00)
- Grease gun (item 17, Table 2, WP 0133 00)

Personnel Required

Three

References

- WP 0133 00
- WP 0135 00
- WP 0019 00
- WP 0106 00
- WP 0113 00

Materials/Parts

- Rags, wiping (item 45, WP 0135 00)
- Grease (item 16, WP 0135 00)

1. Move vehicle back and forth two or three times over hard, level ground. Coast to a stop and stop engine (WP 0019 00).
2. Open armor skirt panel #1 (WP 0106 00).
3. Using wire brush, clean shaft (1) of track adjusting link (2).
4. Using rag, clean grease bleed valve (3), pressure relief valve (4) and grease fitting (5).
5. Connect grease gun adapter, (6) to grease fitting (5).

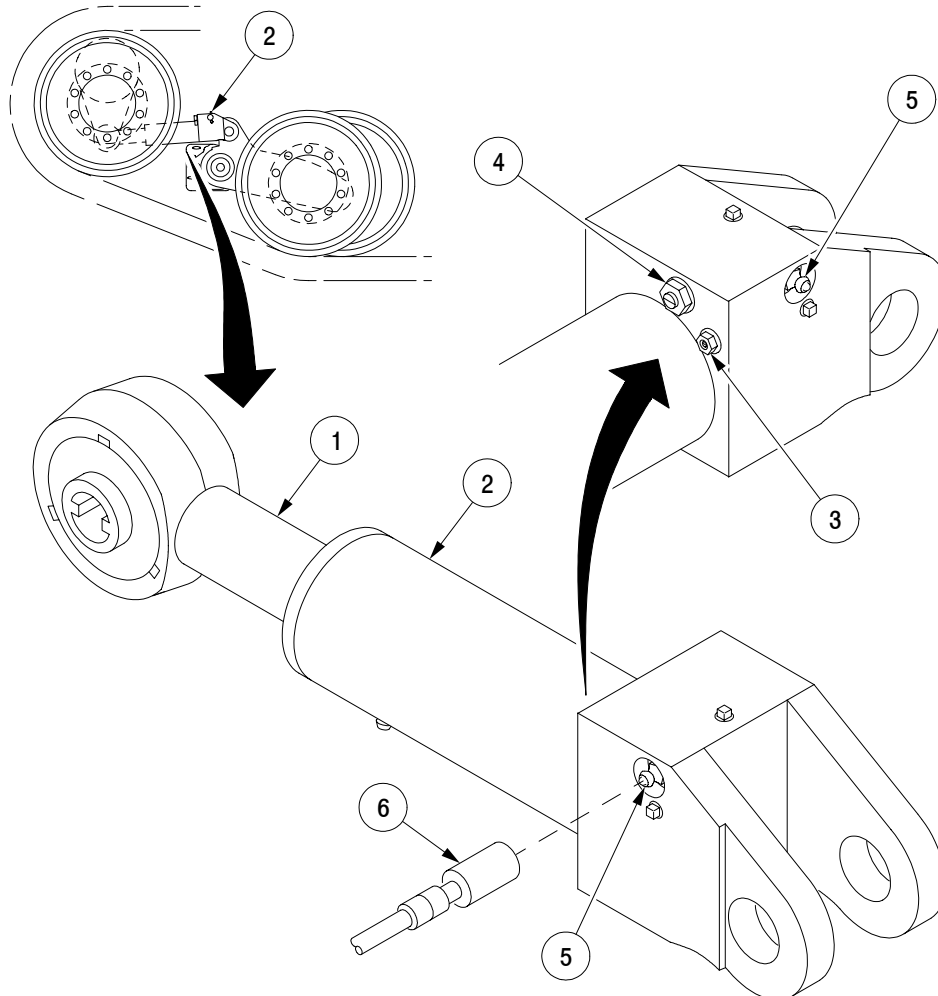

13i046m

WARNING

Grease will be under pressure. Personnel must wear goggles. Failure to comply may result in eye injury to personnel.

NOTE

If grease fitting will not take grease or continues to leak grease after one minute, replace grease fitting.

If pressure relief valve or grease bleed valve works too easily, or if track adjusting link will not move, notify unit maintenance.

If bronze link overextension indicator is exposed on shaft during adjustment, track adjusting link is extended too far. Remove one track shoe (WP 0113 00) and restart task.

Removing a shoe from one track does not require removing a shoe from other track.

- Using a grease gun, pump grease into track adjusting link grease fitting (5) until grease spurts out of pressure relief valve (4).

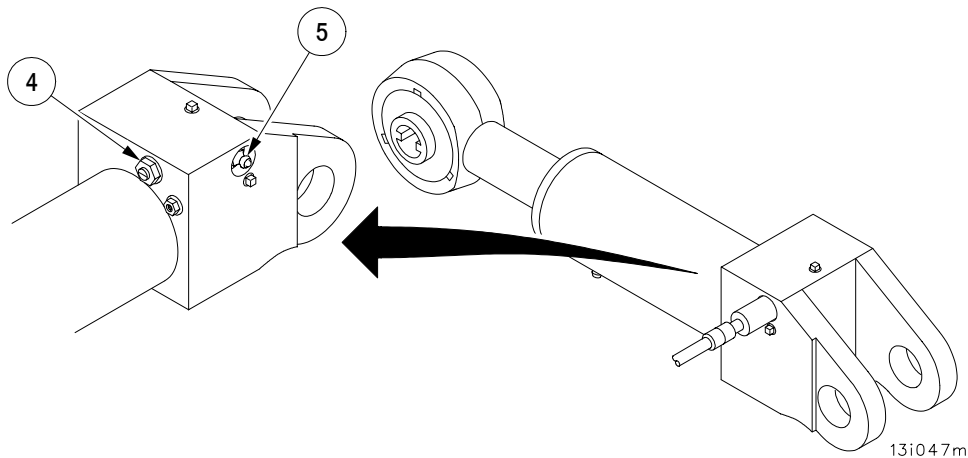

TRACK TENSION ADJUSTMENT (NEW CONFIGURATION) - CONTINUED**0109 00**

7. Disconnect grease gun adapter (6) from grease fitting (5).
8. Repeat steps 1 through 7 for other side of vehicle.
9. Repeat Steps 1 through 7 two additional times, for a total of three times, for each side of vehicle alternately.
10. Close and secure armor skirt panel #1 (WP 0106 00).

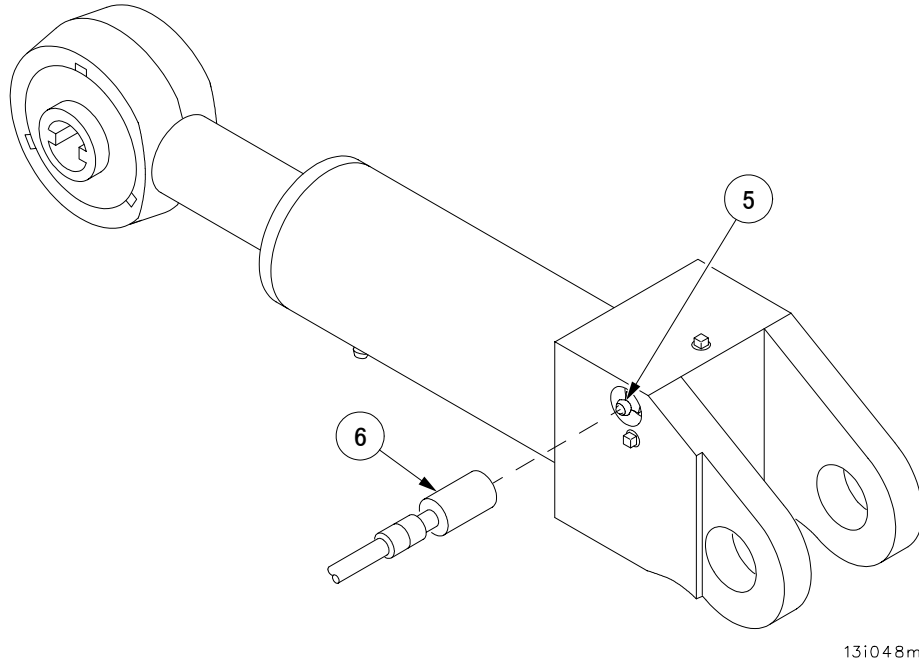
**END OF TASK**

RELEASE TRACK TENSION (OLD CONFIGURATION)**0110 00****THIS WORK PACKAGE COVERS:**

Release

INITIAL SETUP:**Tools and Special Tools**

Wire brush
 Grease gun adapter (item 2, Table 2, WP 0133 00)
 Grease gun (item 17, Table 2, WP 0133 00)
 Adjustable wrench (item 40, Table 2, WP 0133 00)
 Spanner wrench (item 44, Table 2, WP 0133 00)
 Screwdriver (item 30, Table 2, WP 0133 00)

Materials/Parts

Rags, wiping (item 45, WP 0135 00)
 Grease (item 16, WP 0135 00)

Personnel Required

Three

References

WP 0133 00
 WP 0135 00
 WP 0019 00
 WP 0014 00
 WP 0106 00

Equipment Conditions

Engine shutdown (WP 0019 00)
 Tracks blocked
 Transmission in neutral (N) (WP 0014 00)
 Armor skirt panel #1 open (WP 0106 00)

1. Using wire brush, clean threads (1) on track adjusting link (2).
2. Using wiping rag (item 45, WP 0135 00), clean relief valve (3) and grease fitting (4) on track adjusting link (2).
3. Loosen lock screw (5) about 3-1/2 turns.
4. Connect grease gun adapter (item 2, Table 2, WP 0133 00) (6) to grease fitting (4).

WARNING

Grease will be under pressure. Personnel must wear goggles. Failure to comply may result in eye injury to personnel.

NOTE

If grease fitting will not take grease, replace grease fitting.
 If relief valve works too easily, or if adjusting link does not move, notify unit maintenance.
 Locknut is released when cylinder assembly of track adjusting link has moved away from locknut.

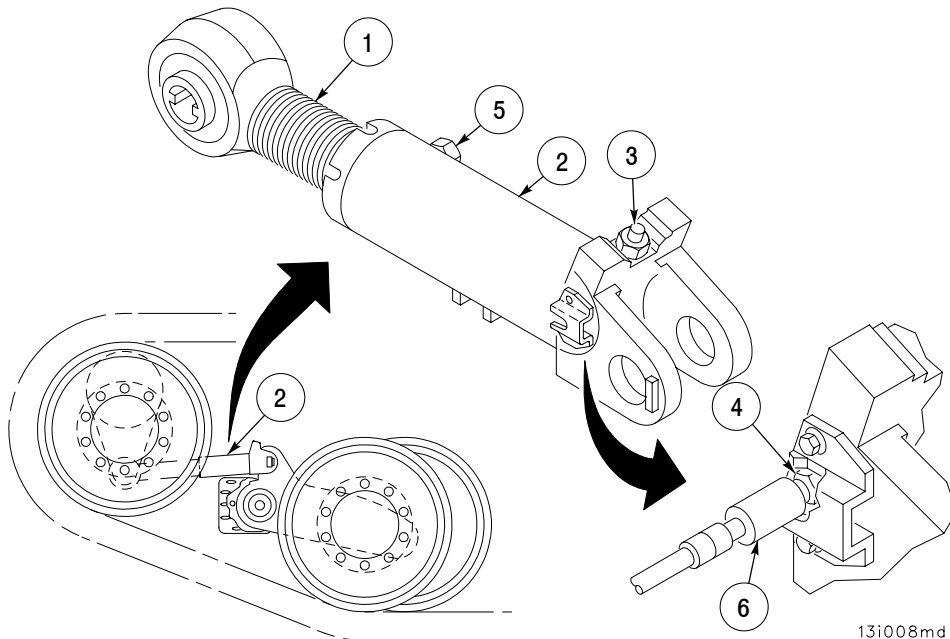

13i008md

**PACKET NAME RELEASE TRACK TENSION (OLD CONFIGURATION) -
CONTINUED**

0110 00

5. Using grease gun, pump grease into grease fitting (4) to help release locknut (7).
6. When locknut (7) is released, stop pumping grease into grease fitting (4).

NOTE

When grease gun adapter is removed from grease fitting, the space between locknut and cylinder assembly should remain the same. If space does not remain the same, replace grease fitting and go back to step 5.

7. Disconnect grease gun adapter (6) from grease fitting (4).
8. Using spanner wrench, unscrew locknut (7) to end of threads (1).
9. Using screw driver, lift up and hold valve pin (8) so grease flows out.
10. Catch grease with wiping rags.
11. Let valve pin (8) go when grease stops flowing out.
12. Wipe up grease with wiping rags.

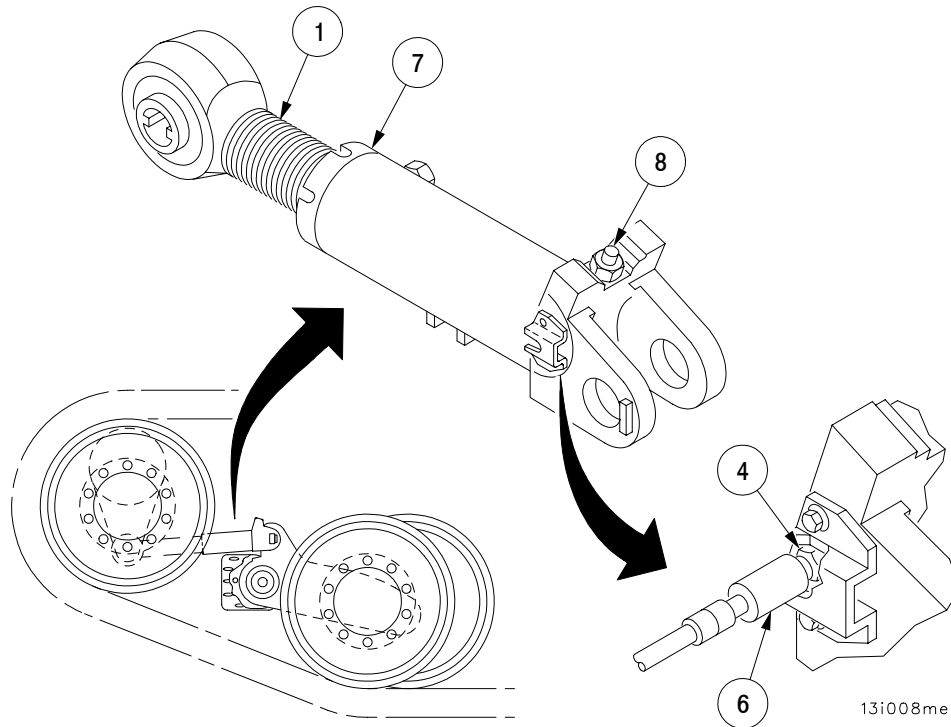
END OF TASK

RELEASE TRACK TENSION (NEW CONFIGURATION)**0111 00****THIS WORK PACKAGE COVERS:**

Release

INITIAL SETUP:**Tools and Special Tools**

Wire brush
 Adjustable wrench (item 40, Table 2, WP 0133 00)
 Screwdriver (item 30, Table 2, WP 0133 00)

Materials/Parts

Wiping rags (item 45, WP 0135 00)
 Grease (item 16, WP 0135 00)

Personnel Required

Three

References

WP 0133 00
 WP 0135 00
 WP 0019 00
 WP 0014 00
 WP 0106 00
 WP 0012 00

Equipment Conditions

Engine shutdown (WP 0019 00)
 Tracks blocked
 Transmission in neutral (N) (WP 0014 00)
 Armor skirt panel #1 open (WP 0106 00)

WARNING

Always release track tension before performing maintenance on track or track adjusting link. Failure to comply may result in injury or death to personnel.

- Using wire brush, clean shaft (1) of track adjusting link (2). Wipe shaft (1) clean with clean wiping rag (item 45, WP 0135 00). Apply coat of grease (item 16, WP 0135 00) to shaft (1).

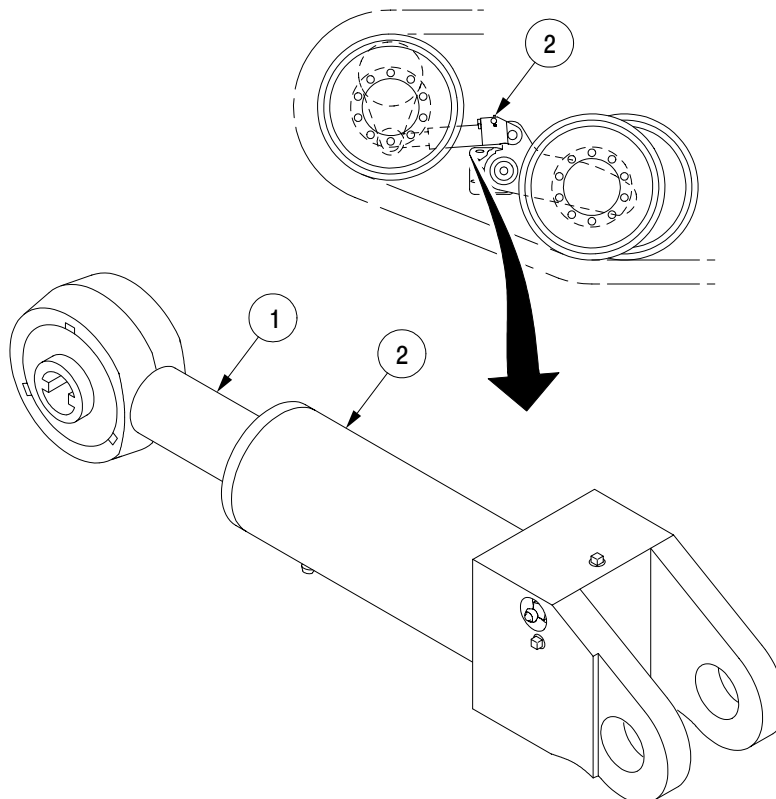

13i049m

RELEASE TRACK TENSION (NEW CONFIGURATION) - CONTINUED**0111 00****WARNING**

Grease will be under pressure. Personnel must wear goggles. Failure to comply may result in eye injury to personnel.

2. Press in and hold plunger (3) on grease relief valve (4) to allow grease to flow out of track adjusting link (2).
3. Catch grease with clean wiping rag.
4. Release plunger (3) when grease stops flowing out of track adjusting link (2).
5. Wipe up grease with wiping rags.

NOTE

If further compression of the track adjusting link is required, perform steps 5 through 10.

6. Remove two machine plugs (5).
7. Start engine (WP 0012 00).
8. To compress track adjusting link, turn vehicle to the rear in the direction opposite to the track adjusting link (2).
9. Shut down engine (WP 0019 00).
10. Install two machine plugs (5).

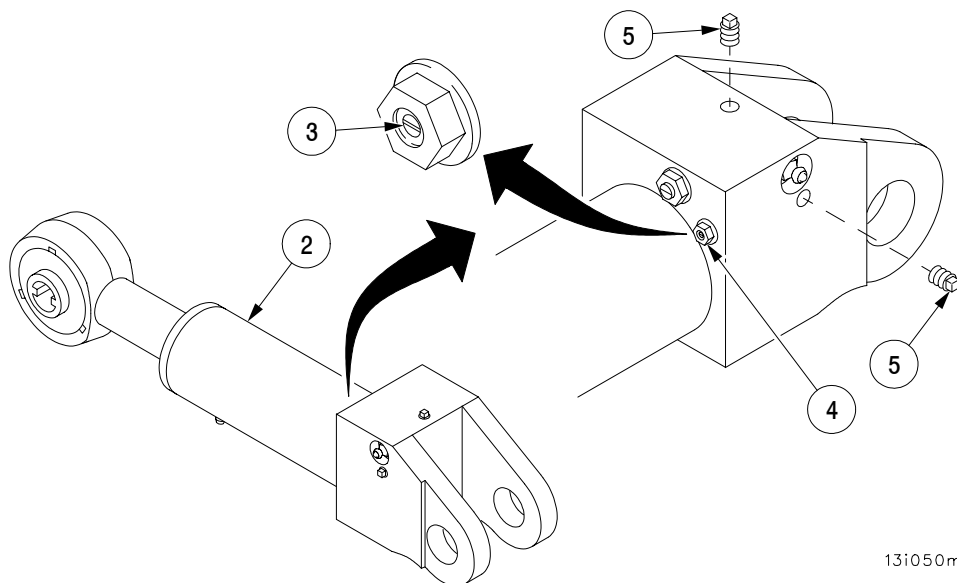

13i050m

END OF TASK

TRACK ADJUSTING LINK GREASE FITTING REPLACEMENT**0112 00****THIS WORK PACKAGE COVERS:**

Replacement

INITIAL SETUP:**Tools and Special Tools**

Lubrication fitting tool (item 23, Table 2, WP 0133 00)

Materials/Parts

Wiping rags (item 45, WP 0135 00)

Personnel Required

Three

References

WP 0133 00

WP 0135 00

WP 0109 00

WP 0108 00

WP 0110 00

WP 0111 00

Equipment Conditions

Track tension released (WP 0110 00 or WP 0111 00)

NOTE

Replacement of track adjusting link grease fitting is the same for both sides.

1. Using lubrication fitting tool (1), remove grease fitting (2) from track adjusting link (3).
2. Clean area around grease fitting (2) with clean rag.
3. Loosely install new grease fitting (2) into track adjusting link (3). Using lubrication fitting tool (1), tighten new grease fitting (2).
4. Adjust track tension (WP 0108 00 or WP 0109 00).

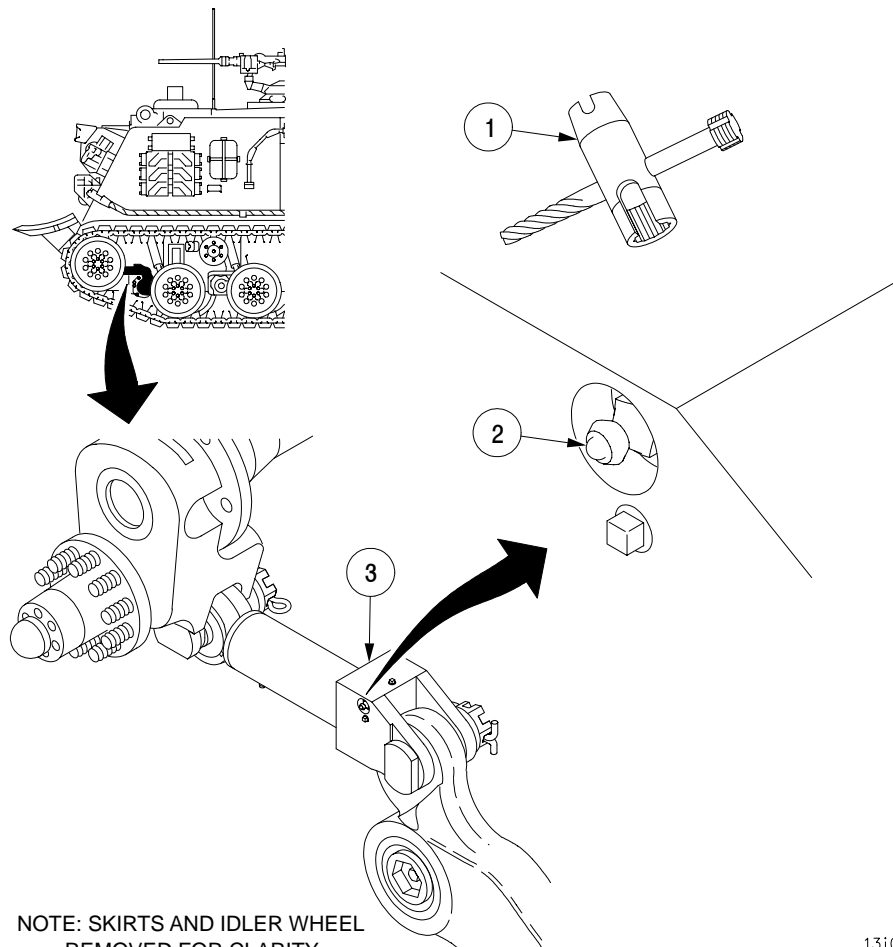

NOTE: SKIRTS AND IDLER WHEEL
REMOVED FOR CLARITY

13i051m

END OF TASK

TRACK SHOE REPLACEMENT**0113 00****THIS WORK PACKAGE COVERS:**

Replacement

INITIAL SETUP:**Tools and Special Tools**

Track binder (item 7, Table 2, WP 0133 00)
 End connector puller and pump (item 28, Table 2, WP 0133 00)
 Sledgehammer (item 32, Table 2, WP 0133 00)
 Track connecting fixtures (item 14, Table 2, WP 0133 00)
 Ratchet (item 38, Table 2, WP 0133 00)
 Tanker's bar (item 5, Table 2, WP 0133 00)

References

WP 0133 00
 WP 0115 00
 WP 0108 00
 WP 0109 00
 WP 0106 00
 WP 0012 00
 WP 0110 00
 WP 0111 00

Personnel Required

Three

1. Position vehicle until shoe to be replaced is between idler wheel and front road wheel.
2. Open armor skirt plates #1, #3, #5 and #7 (WP 0106 00).
3. Install track binder (WP 0115 00).
4. Release track tension (WP 0110 00 or WP 0111 00).

**NOTE**

Disconnect track between idler wheel and first roadwheel.

5. Remove two bolts (1) and two wedges (2) from two end connectors (3). After loosening bolt a few turns, rap bolt with sledgehammer sharply to loosen wedge.
6. Hit end connector (3) with sledgehammer to loosen.
7. Place hook (5) of end connector puller (4) behind end connector (3).
8. Align two studs (6) with shoe pins (7).
9. Pump handle (8) until gap between end connector (3) and track shoes (9) is about 1 in. (2.5 cm).

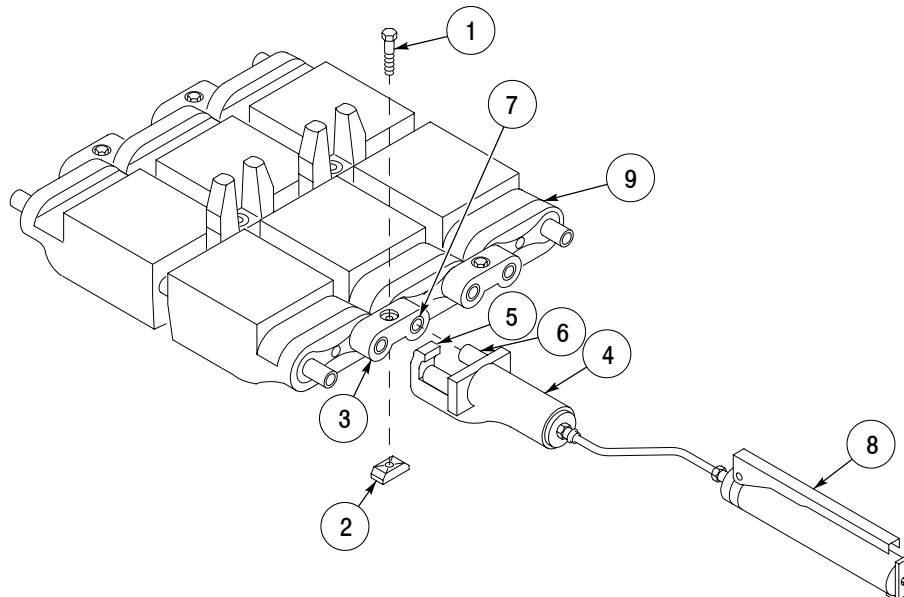

TRACK SHOE REPLACEMENT - CONTINUED**0113 00**

10. Put track connecting fixture (10) between end connector (3) and track shoes (9).
11. Hook jaws (11) around track shoe pins (12).
12. Using ratchet (13), turn screw (14) until jaws (11) are tight against track shoe pins (12).
13. Pump handle (8) until end connector (3) is removed from track shoe pins (12).
14. Check end connector (3) for cracks or breaks. Replace as required.
15. Repeat steps (6) through (14) on the opposite side of track shoe with 2nd track connecting fixture (10).

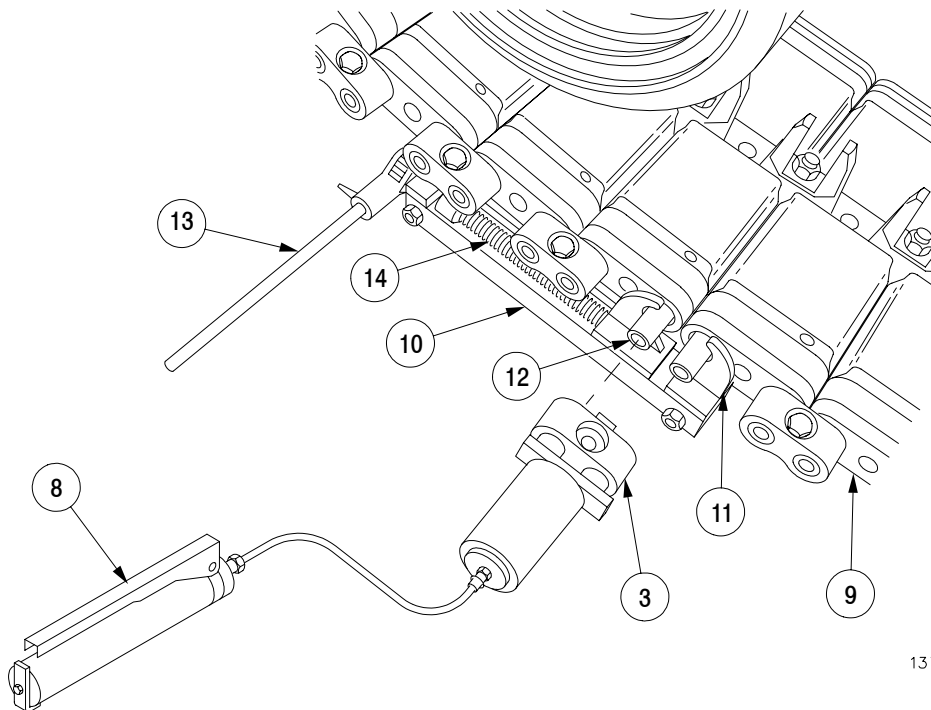

13i009m

TRACK SHOE REPLACEMENT - CONTINUED**0113 00**

16. Remove nut (15), bolt (16), and track center guide (17).
17. Loosen the two track connecting fixtures (10) evenly.
18. Hold track up with tanker's bar and remove track connecting fixtures (10).
19. Separate track.
20. Remove center guide (17) and end connectors (3) of track shoes to be replaced.
21. Remove track shoes from stowage by loosening nuts (18) and clamps (19).
22. Install center guide (17) and end connectors (3) on track shoes being replaced.
23. Hold track up with bar and install two track connecting fixtures (10).
24. Pull track together with track connecting fixtures (10) until center guide (17) can be installed.
25. Install center guide (17), bolt (16), and nut (15). Tighten bolt (16) and nut (15).
26. Using sledgehammer, install end connectors (3) on both sides of track shoe pins (12).
27. Remove track connecting fixtures (10).
28. Remove track binder (WP 0115 00).
29. Use sledgehammer to move end connectors (3) tight against track.
30. Install wedge (2) and bolt (1) in each end connector (3).
31. Move vehicle so track shoe assembly is starting over compensating idler wheel.
32. Tighten end connector bolt (1) in each end connector (3).
33. Adjust track tension (WP 0108 00 or WP 0109 00).
34. Close armor skirt plates #1, #3, #5 and #7 (WP 0106 00).
35. Notify unit maintenance that end connector and center guide bolts require torque as soon as possible. Torque again after 50 miles.

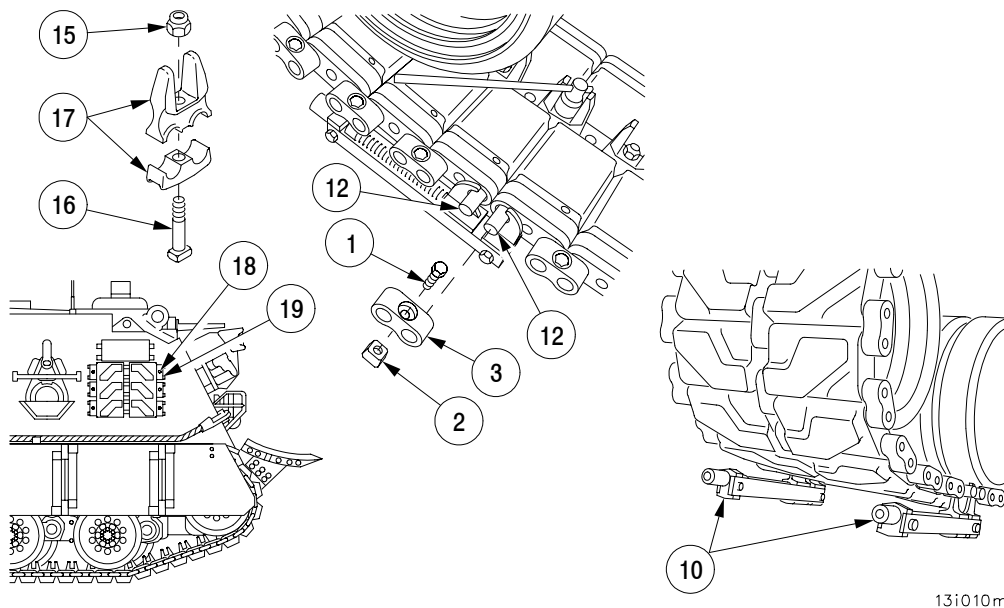

131010m

END OF TASK

TRACK REMOVAL**0114 00****THIS WORK PACKAGE COVERS:**

Removal

INITIAL SETUP:**Tools and Special Tools**

- Track binder (item 7, Table 2, WP 0133 00)
- Adjustable wrench (item 40, Table 2, WP 0133 00)

Materials/Parts

- Rope, fibrous (item 29, Table 2, WP 0133 00)

Personnel Required

Three

References

- WP 0133 00
- WP 0014 00
- WP 0113 00
- WP 0012 00
- WP 0019 00
- WP 0106 00
- WP 0115 00

**WARNING****NOTE**

If both tracks are to be replaced, do only one at a time.

1. Disconnect track (WP 0113 00, steps 1 through 19).
2. Remove screw (1) and lockwasher (2) from fender section (3).
3. Secure fender in the up position using rope or wire.
4. Start main engine (WP 0012 00).
5. Turn steering wheel to right if removing left track or turn steering wheel left if removing right track.
6. Shift transmission selector (4) to R (WP 0014 00) and release brakes.

**WARNING**

7. Using ground guides, move vehicle slowly backwards, keeping a constant, slow speed so track does not become fouled up in the support rollers.
8. As soon as track leaves sprocket, apply brakes and shift transmission selector to P (WP 0014 00), locking the steering wheel and brakes. Stop main engine (WP 0019 00).
9. Remove track binder ((WP 0115 00).
10. Close armor skirt plates #1, #3, #5 and #7 (WP 0106 00).

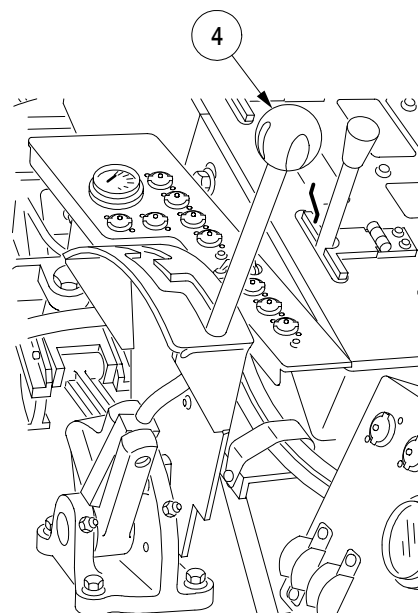
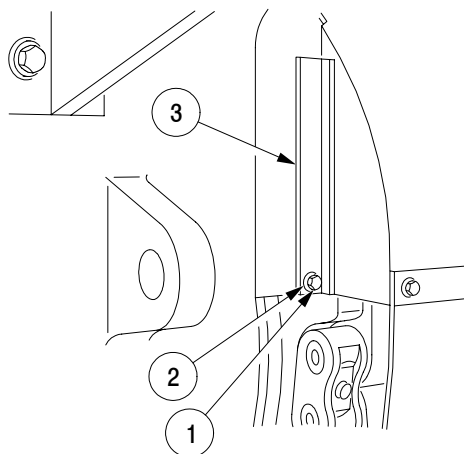

07i006m

END OF TASK

TRACK INSTALLATION

0115 00

THIS WORK PACKAGE COVERS:

Installation

INITIAL SETUP:

Tools and Special Tools

- Track binder (item 7, Table 2, WP 0133 00)
- Adjustable wrench (item 40, Table 2, WP 0133 00)
- Tankers bar (item 5, Table 2, WP 0133 00)
- Track connecting fixtures (2) (item 14, Table 2, WP 0133 00)
- Sledgehammer (item 32, Table 2, WP 0133 00)

Materials/Parts

- Rope, fibrous (item 29, Table 2, WP 0133 00)

Personnel Required

Three

References

- WP 0133 00
- WP 0108 00
- WP 0012 00
- WP 0109 00
- WP 0106 00
- WP 0014 00
- WP 0019 00



WARNING

1. Lay out new or thrown track (1) in front of vehicle and in line with the roadwheels (2) with the “V” pattern of the track pads pointing to the rear.

NOTE

If installing new track, temporarily attach new track to old track with two end connectors but without wedges or bolts.

2. Place heavy metal plate or sturdy plank (3) on track link near vehicle to form a ramp. If plate or plank are not available, dig a trough under the first few track links so that the upper surface of the links are level with or slightly below ground surface.
3. Start main engine (WP 0012 00).
4. Shift transmission selector to first gear (1st) (WP 0014 00) and release brakes.
5. Turn steering wheel in the direction of the track being installed.
6. Using ground guides move vehicle forward onto track (1) until center of first roadwheel (2) is resting on top of the 16th track link from front of track.
7. Apply brakes and shift transmission selector to park (P) (WP 0014 00).
8. Open armor skirt plates #1, #3, #5, and #7 (WP 0106 00).

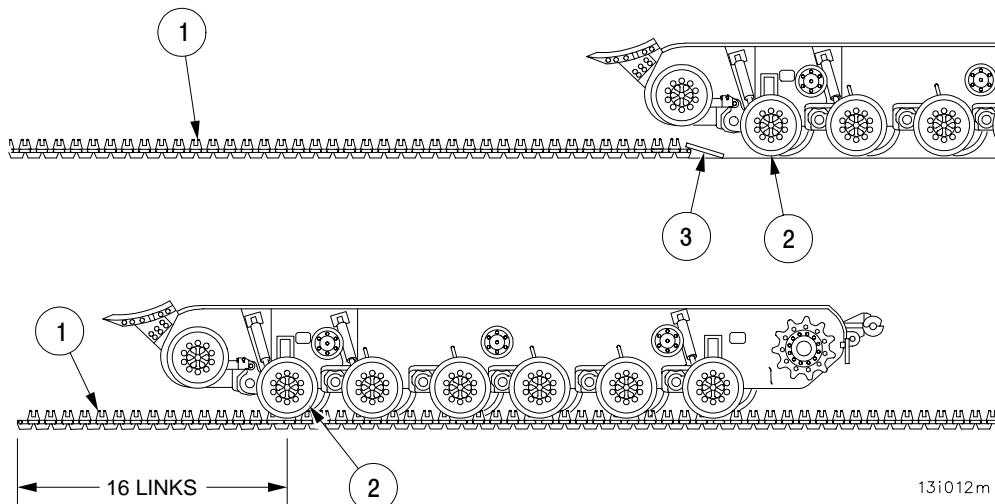

13i012m

SIDE ARMOR SKIRT PANELS REMOVED FOR CLARITY

TRACK INSTALLATION - CONTINUED**0115 00**

9. Install track binder (4) into retainers (5 and 6) and behind the three track support rollers (7).
10. Tighten track binder (4) to support the weight of track (1) between support rollers (7), sprocket (8) and idler wheel (9).
11. Tie rope (10) to center of front track shoe in front of vehicle.
12. Guide rope over compensating idler wheel (9), through center guide grooves of support rollers (7), to drive sprocket (8).
13. Raise front of track (1) as high as possible by hand.
14. Keep rope (10) taut, wrap two turns of rope around drive sprocket (8), (clockwise for left hand track, counterclockwise for right hand track) and over and around top sprocket tooth (11).
15. With engine at idle, shift transmission selector to R (WP 0014 00) and release brakes.
16. Holding free end of rope (10) taut, stand to the side of drive sprocket (8). This setup forms a power pulley system which pulls front of track (1) onto compensating idler wheel (9).
17. When track (1) starts over compensating idler wheel (9), move slowly backwards keeping rope (10) taut around drive sprocket (8).
18. Carefully guide track over support rollers (7).
19. When end of track has engaged drive sprocket (8), stop vehicle, unwind rope (10) from drive sprocket (8) and pull straight back, thereby guiding track (1) over drive sprocket (8).
20. Apply brakes and place transmission shift lever in park (WP 0014 00) and shut off engine (WP 0019 00).
21. Disconnect rope (10) from track (1).
22. Remove the track binder (4).

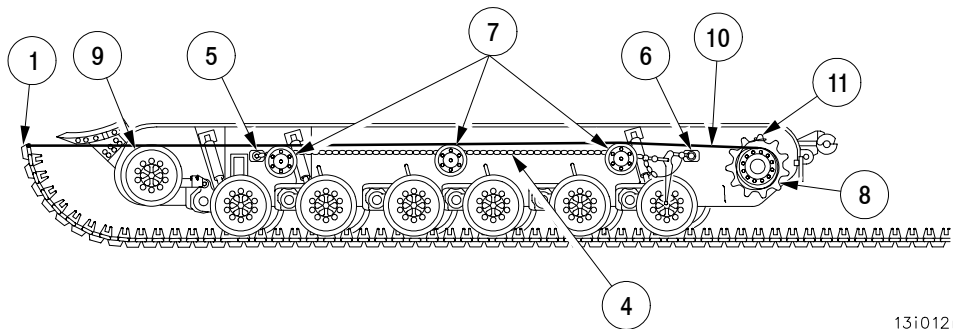

13i012m

SIDE ARMOR SKIRT PANELS REMOVED FOR CLARITY

TRACK INSTALLATION - CONTINUED**0115 00**

23. Using tanker's bar bring both ends of track (1) together and install track connecting fixtures (12) .
24. Tighten track connecting fixtures (12) evenly to bring link pins (13) together.
25. Install center guide (14) and two end connectors (15), but do not tighten.
26. Remove track connecting fixtures (12) by using sledgehammer drive on two end connectors.
27. Tighten bolt on center guide and install two wedges and two bolts on two end connectors.
28. Start main engine (WP 0012 00) and shift transmission selector to R (WP 0014 00).
29. Release brakes and slowly move vehicle backward until connection point is on curve of compensating idler wheel. Tighten bolts on end connector.
30. Adjust track tension (WP 0108 00 or WP 0109 00).
31. Notify unit maintenance to torque end connector and center guide bolts as soon as possible. Torque bolts again after 50 miles.
32. Install fender section (18) with lockwasher (17) and screw (16).
33. Close skirts #1, #3, #5 and #7 (WP 0106 00).

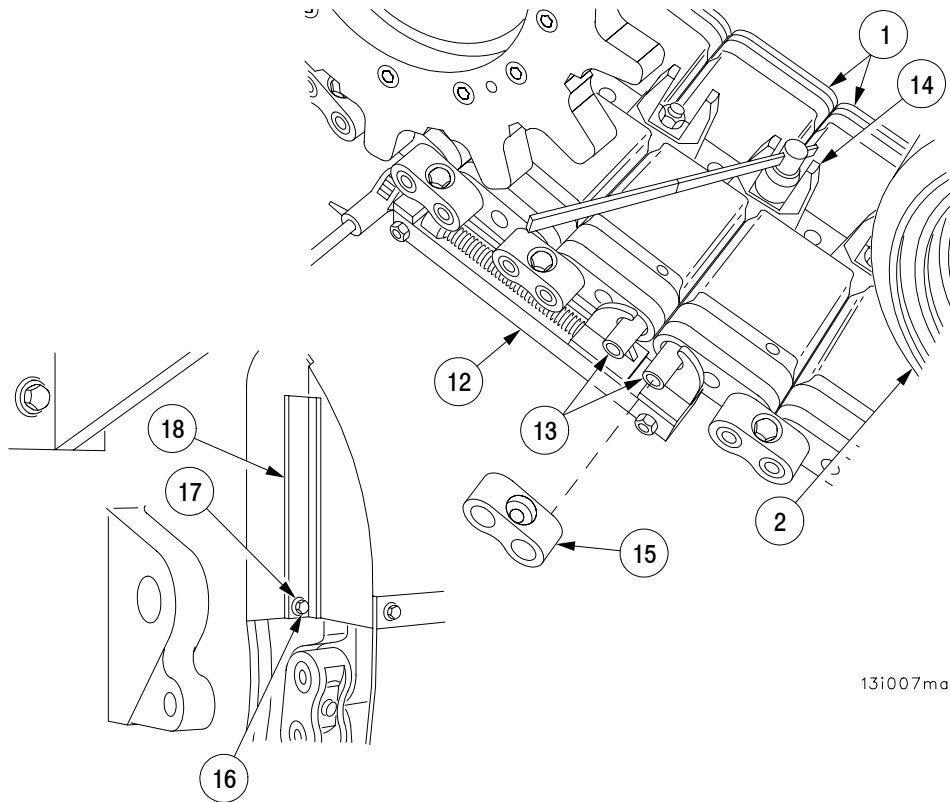
**END OF TASK**

AIR CLEANER MAINTENANCE**0116 00****THIS WORK PACKAGE COVERS:**

Servicing Main Engine Air Cleaner, Air Cleaner Restriction Gauge, Servicing Air Intake Screens, Servicing Dust Cover, Servicing Filter Elements

INITIAL SETUP:**Materials/Parts**

Detergent (item 10, WP 0135 00) (Servicing filter element)

Personnel Required

Three

References

WP 0135 00

SERVICING MAIN ENGINE AIR CLEANER

The main engine air cleaner is the only source of air to the main engine. It is the crew's responsibility to ensure that it is properly maintained to avoid damaging the main engine. Maintenance instructions are given for the air intake screens, air cleaner dust cover and the filter element.

AIR CLEANER RESTRICTION GAUGE

A restriction gauge (1) is located above each air cleaner. It indicates green when the air cleaner is working properly. As the filter becomes restricted, a red sleeve (2) begins to drop into view. The air flow restriction is maximum when the red sleeve fully covers the green and locks into place. When this happens, the filter element must be cleaned or replaced (in accordance with this work package). To reset the gauge, press the top of the gauge (1).

SERVICING AIR INTAKE SCREENS

Clean away any dirt, mud or leaves restricting the free flow of air through the air intake screens (3 and 4).

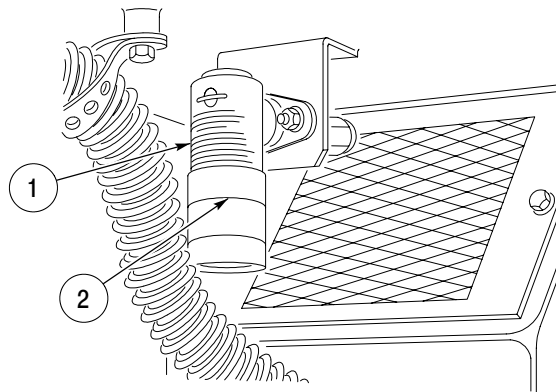

031004m

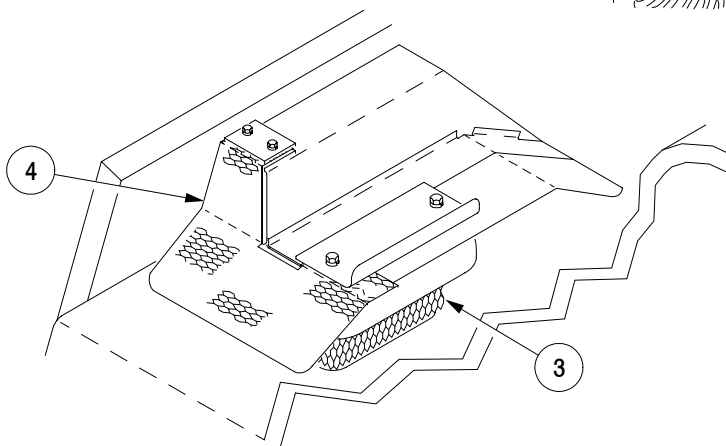

181048m

AIR CLEANER MAINTENANCE - CONTINUED

0116 00**SERVICING DUST COVER**

The air cleaner dust cover must be removed and cleaned daily or more often as required (in accordance with this work package). Be sure the filter element wingnut is tight each time you remove the dust cover. Open dust cover cap, clean out dust, wipe with a clean, damp cloth and replace.

SERVICING FILTER ELEMENTS

When the restriction gauge window is completely red, the filter element must be removed, and cleaned or replaced.

**WARNING****CAUTION**

Do not hit filter on a hard surface to clean. Damage to the seals may occur which will allow dirt to enter the engine and degrade performance.

Do not wash filter more than two times. When filter is due for third washing, replace it. Failure to comply may result in damage to equipment or degraded filtration.

AIR CLEANER MAINTENANCE - CONTINUED**0116 00****SERVICING FILTER ELEMENTS - CONTINUED**

1. Loosen and pull away four wingnut clamps (1) from dust cover (2).
2. Remove dust cover (2).
3. Remove wingnut (3) and pull ring (4) to remove dust cover baffle (5).
4. Clean dust cover (2) interior and dust cover baffle (5) with a damp cloth.
5. Unscrew filter element wingnut (6) and remove filter element (7).

NOTE

Check date scribed on filter bottom. If two dates are present, replace filter. Filter may be washed two times before it must be replaced.

6. Rinse away dust from filter element (7) with clean water at no more than 10 psi.
7. Soak filter element (7) in lukewarm water using nonfoaming detergent for 15 minutes. Do not use solvents, fuel oils, or gasoline.

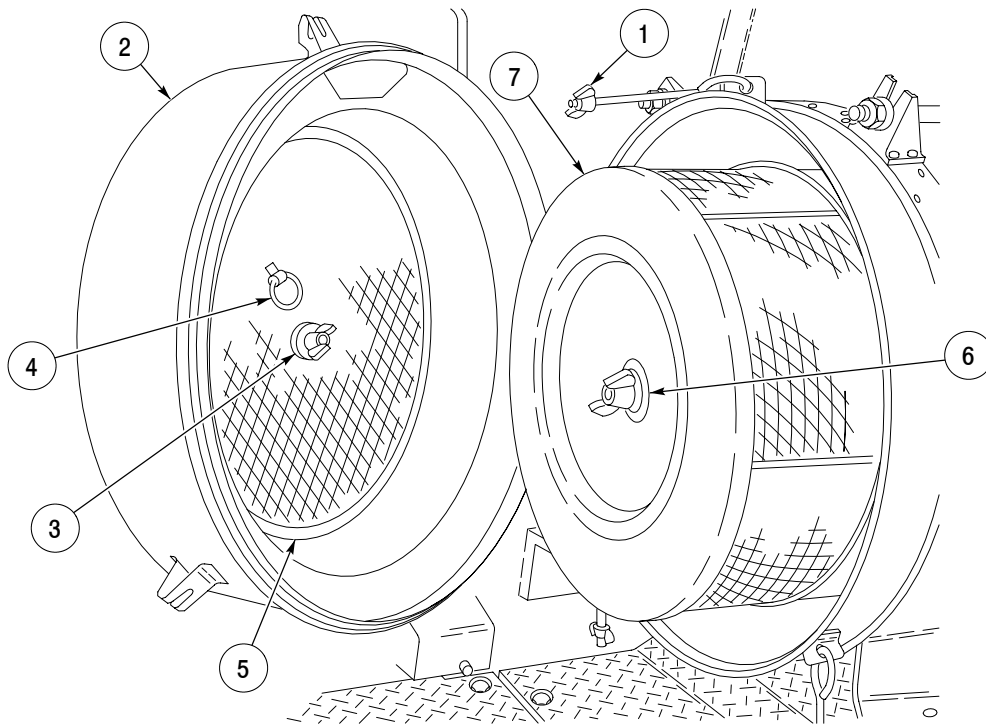

03i003m

AIR CLEANER MAINTENANCE - CONTINUED**0116 00****SERVICING FILTER ELEMENTS - CONTINUED**

8. Shake filter element (7) slightly before removing from water.
9. Rinse filter element (7) with clean water (not more than 10 psi) from inside out.
10. Shake filter element (7) lightly to remove excess water.
11. Set filter element (7) aside in a dust free area to dry or circulate heated air at no more than 150°F (65°C).
12. Wipe the inside of the air filter housing (8) with a clean, damp cloth.
13. Before putting filter element (7) back, inspect it for tears or holes. If any are found, replace filter element (7).
14. Use a sharp pointed tool to scribe the date the filter was cleaned on the bottom of the filter element (7).
15. Install filter element (7) and hand tighten filter element wingnut (6).
16. Install dust cover baffle (5) and hand tighten wingnut (3).
17. Install dust cover (2) and hand tighten four wingnut clamps (1).
18. Reset restriction gauge in accordance with this work package.

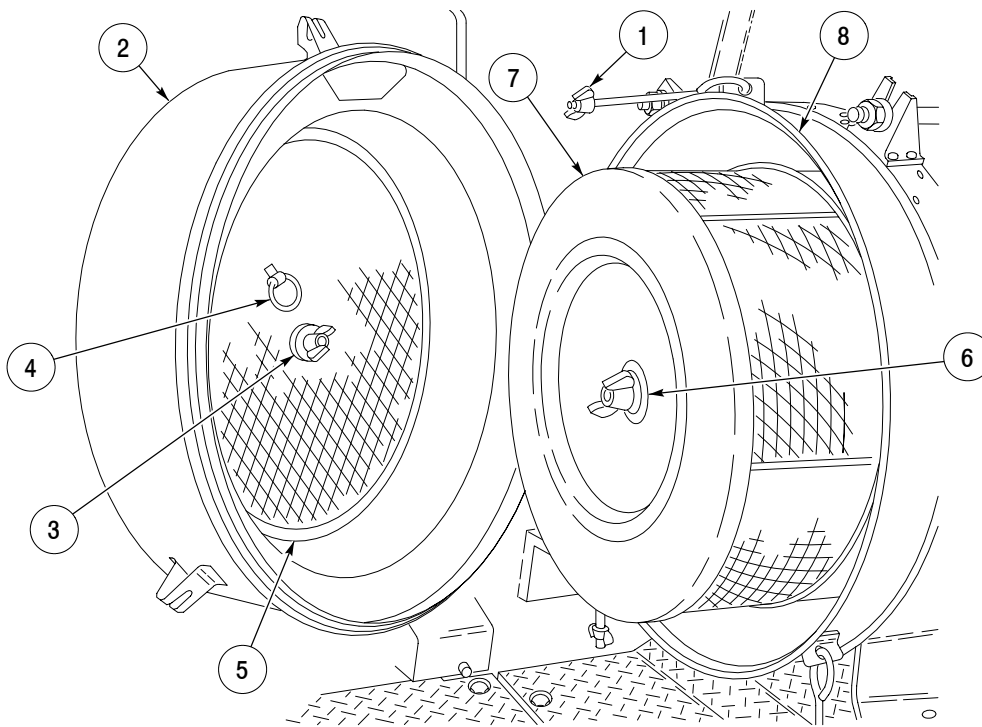

03i003m

END OF TASK

AUXILIARY POWER UNIT AIR CLEANER MAINTENANCE**0117 00****THIS WORK PACKAGE COVERS:**

Servicing

INITIAL SETUP:**Materials/Parts**

Detergent (item 10, WP 0135 00)
Wiping rags (item 45, WP 0135 00)

Personnel Required

Three

References

WP 0135 00

The Auxiliary Power Unit air cleaner is located on the right rear wall behind the personnel heater. It supplies air to the APU.

1. Unlatch two air cleaner filter housing clips (1) and remove housing cover (2) from filter housing (3).
2. Remove wing nut (4), gasket (5), plate (6) and filter element (7) from housing (3).

NOTE

Check for dates on the bottom of the filter element. If two dates are present, replace filter element. Filter element may be washed two times before it must be replaced.

3. Rinse away dust from filter element (7) with clean water at no more than 10 psi (69 kp).
4. Soak filter element (7) in lukewarm water using nonfoaming detergent for 15 minutes. Do not use solvents, fuel oils, or gasoline.
5. Shake filter element (7) slightly before removing from water.
6. Rinse filter element (7) with clean water (not more than 10 psi (69 kp) from inside out.

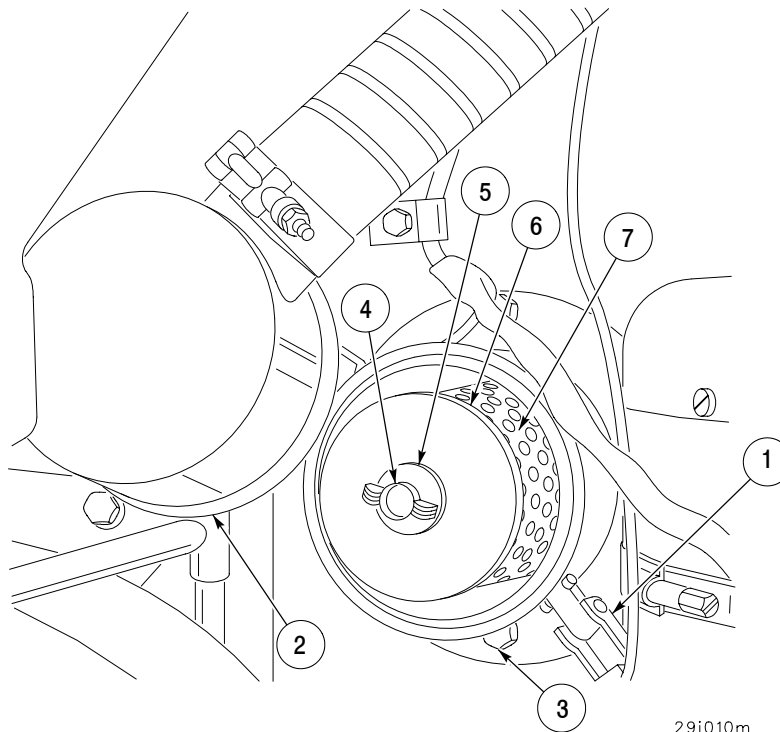

AUXILIARY POWER UNIT AIR CLEANER MAINTENANCE - CONTINUED**0117 00**

7. Shake filter element (7) lightly to remove excess water.
8. Set filter element (7) aside in a dust free area to dry or circulate heated air at no more than 150°F (65°C).
9. Wipe the inside of the air filter housing cover (2) with a clean, damp cloth.
10. Before putting filter element back, inspect it for tears or holes. If any are found, replace filter element (7).
11. Use a sharp, pointed tool to scribe the date the filter element was cleaned on the bottom of the filter element (7).
12. Install filter element (7) and plate (6) in filter housing (3), and install wingnut (4) with gasket (5). Hand tighten wingnut (4).
13. Install air cleaner filter housing cover (2) on filter housing (3) and secure with two filter housing clips (1).

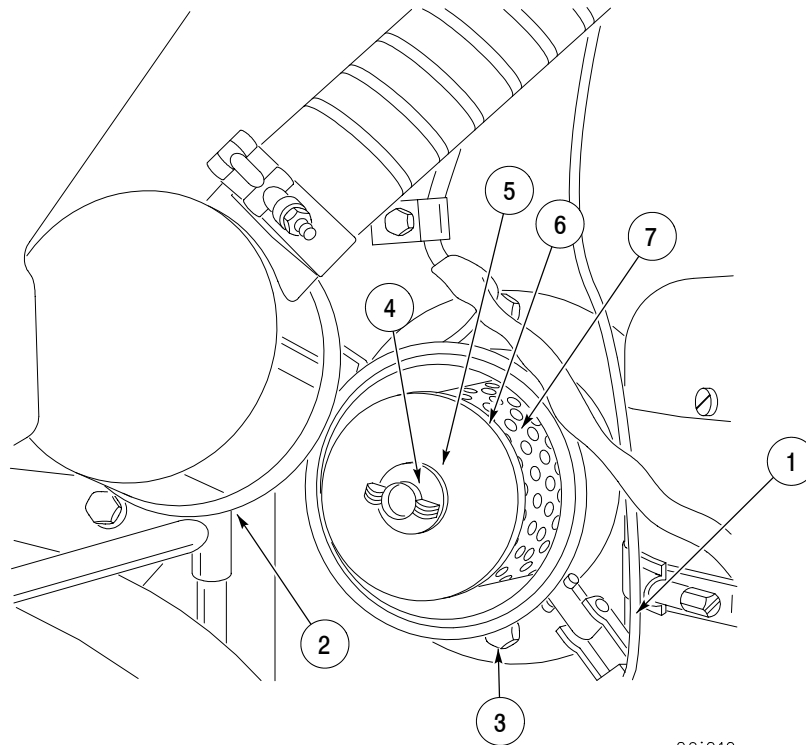
**END OF TASK**

INSTRUMENT, DOME AND BLACKOUT MARKER LIGHTS MAINTENANCE

0118 00

THIS WORK PACKAGE COVERS:

Replacement of Instrument Panel Light, Dome Light Lamp Replacement, Blackout Marker Light Lamp Replacement

INITIAL SETUP:

Tools and Special Tools

Screwdriver (item 30, Table 2, WP 0133 00) (For domelight lamp or blackout marker light lamp replacement)

Personnel Required

Three

References

WP 0133 00

The crew is authorized to change the dome, instrument and blackout marker lamps on the vehicle. Notify unit maintenance for other services.

INSTRUMENT PANEL LIGHT LAMP REPLACEMENT

1. Unscrew lens (1).
2. Push in and turn lamp (2) to left and remove.
3. Push in and turn new lamp (2) to right to install.
4. Screw lens (1) into instrument panel.

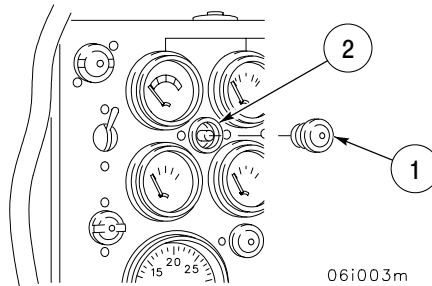

DOME LIGHT LAMP REPLACEMENT

1. Loosen eight screws (1) and remove dome light cover from dome light assembly.
2. Push in and turn lamp (2) or lamp (3) to remove.
3. Push in and turn new lamp (2) or new lamp (3) to install.



Ensure dome light assembly is properly positioned on bracket before securing screws to prevent damage to seal.

4. Place dome light cover on dome light assembly and tighten eight screws (1).

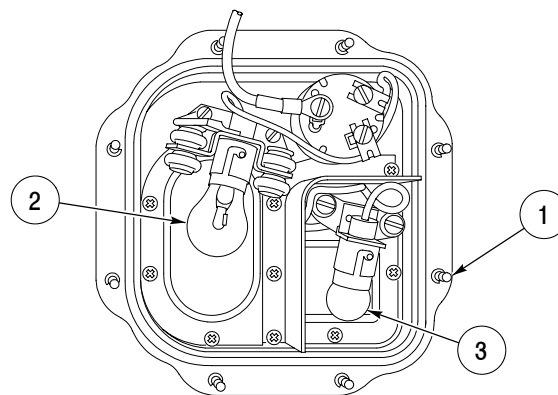

**INSTRUMENT, DOME AND BLACKOUT MARKER LIGHTS MAINTENANCE -
CONTINUED****0118 00****BLACKOUT MARKER LIGHT LAMP REPLACEMENT**

1. Loosen four screws (1) and remove cluster cover (2).
2. Push in and turn blackout driver lamp (3) and remove.
3. Push in and turn new blackout driver lamp (3) to install.

CAUTION

Ensure cluster cover is properly positioned on headlight assembly before securing screws to prevent damage to seal.

4. Place cluster cover (2) in place and tighten four screws (1).

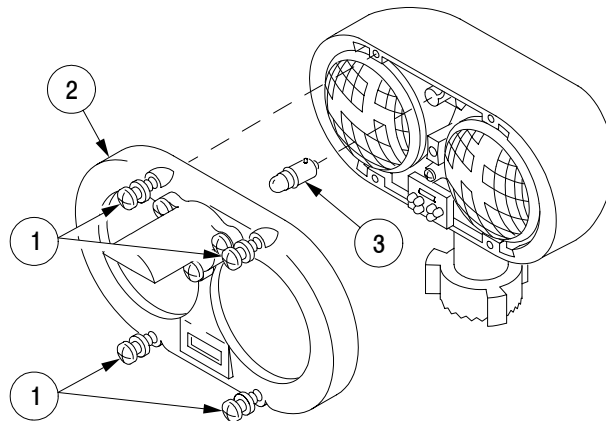

06i038m

END OF TASK

VISION DEVICES MAINTENANCE**0119 00****THIS WORK PACKAGE COVERS:**

Care and Handling of Vision Devices, Cleaning Vision Device Lens, M17 Periscope Replacement

INITIAL SETUP:**Materials/Parts**

Paper, lens tissue (item 35, WP 0135 00)

Personnel Required

Three

References

TM 11-5855-249-10

WP 0135 00

CARE AND HANDLING OF VISION DEVICES

1. For care and handling of passive night viewer AN/VVS-2(V)1A see TM 11-5855-249-10.
2. Vision devices are generally rugged, but mishandling will result in damage to the equipment.
3. Touch up scratched or chipped areas that expose bare metal. Never paint the whole device.

CLEANING VISION DEVICE LENS

1. Keep lenses clean and dry. Proper care will ensure good vision. See step (4).
2. It is prohibited to clean lenses and windows with liquid, pastes or abrasives.
3. Use lens tissues (item 35, WP 0135 00) only to wipe lenses and windows.
4. Keep lenses free of oil or grease. Do not touch lenses or windows with fingers. Use alcohol on lens tissue to remove grease or oil. If no alcohol is available, use lens tissue.

M17 PERISCOPE REPLACEMENT

1. Loosen wing nut (1) and turn retainers (2) until they clear periscope (3).
2. Pull down on periscope (3) to remove it from recess.
3. Insert periscopes (3) into recess and push it into place.
4. Turn retainers (2) until they contact the periscope (3) and tighten wing nuts (1).

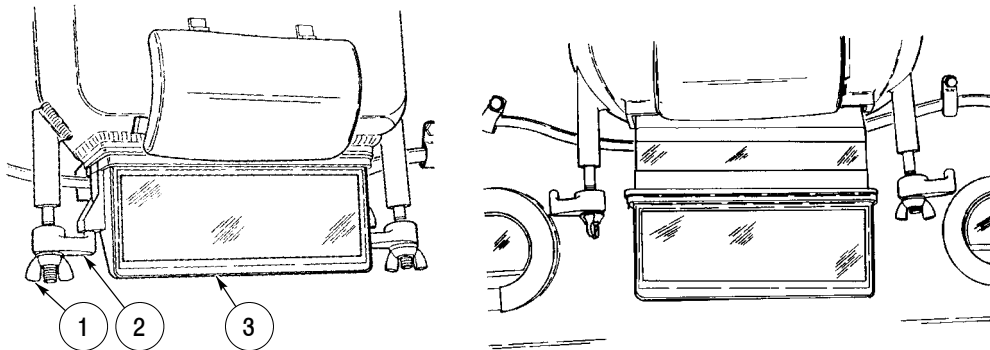
**END OF TASK**

TURBO DUST DETECTOR MAINTENANCE**0120 00****THIS WORK PACKAGE COVERS:**

Servicing

INITIAL SETUP:**Tools and Special Tools**

Adjustable wrench (item 40, Table 2, WP 0133 00)

Personnel Required

Three

References

WP 0133 00

WP 0034 00

WP 0047 00

1. Raise boom (WP 0047 00).
2. Open engine deck side grilles (WP 0034 00).
3. Loosen three screws (1) on turbo dust detector (2).
4. Unspool filter paper (3) until contaminated portion can be removed.
5. Tighten three screws (1) on turbo dust detector (2).
6. Tear off filter paper (3).
7. Reset turbo dust detector (2) by pressing in on detector pressure switch (4).
8. Repeat steps c through g for other turbo dust detector.
9. Close engine deck side grilles (WP 0034 00).
10. Continue with mission and monitor indicator.
11. Upon completion of mission, notify unit maintenance.

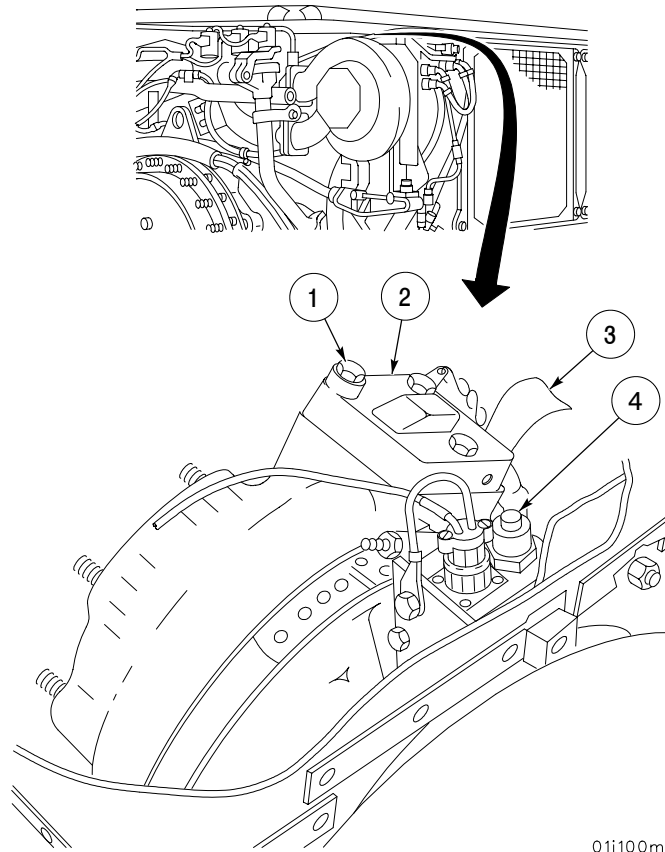

01i100m

END OF TASK

REFUELING**0121 00****THIS WORK PACKAGE COVERS:**

Refueling

INITIAL SETUP:**Personnel Required**

Three

References

WP 0019 00

**WARNING****WARNING**

Use goggles and proper grounding procedures during refueling to prevent serious injury or DEATH to personnel.

1. Shut down engine (WP 0019 00).
2. Ensure MASTER SWITCH is OFF.
3. Ground fuel hose nozzle to vehicle.
4. Before removing protective cap (1), clean away debris.
5. Remove two pins (2) from protective cap (1) and remove protective cap (1).
6. Remove fuel cap (3) slowly.
7. Fill to level at bottom of filler neck screen.
8. Remove fuel hose nozzle ground from vehicle.
9. Install fuel cap (3).
10. Install fuel protective cap (1) with two pins (2).

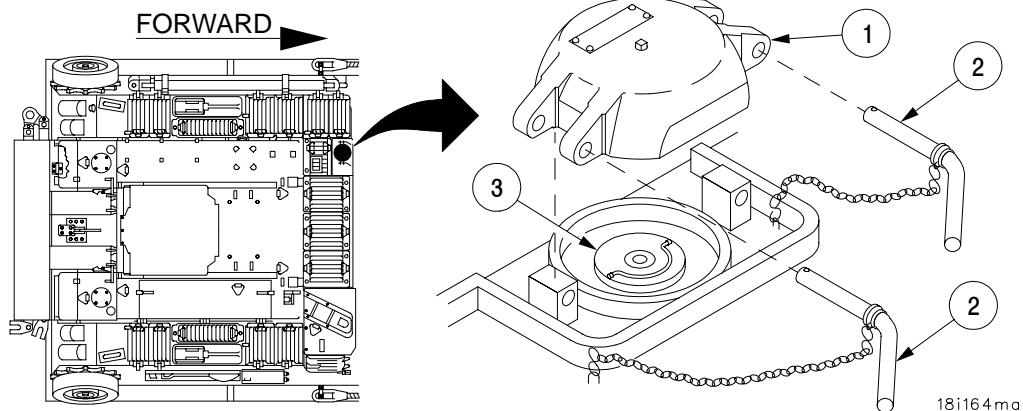
**END OF TASK**

BLEEDING TRAPPED AIR FROM BRAKE LINES

0122 00

THIS WORK PACKAGE COVERS:

Bleeding trapped air from brake lines

1. Turn MASTER switch (1) OFF.
2. Slowly depress and release brake pedal (2) until pressure gauge (3) reading is between 100–150 psi (689–1034 kPa) (old configuration).
3. Slowly pull bleed valve knob (4) and hold open for 5 seconds. Listen for trapped air being released into reservoir. When gurgling sound stops, air in brake lines has been purged. Release bleed valve knob (4) (new configuration), new configuration with brake modulation and new configuration with brake modulation and enhanced parking brake.

NOTE

Pump motor starts when brake pressure drops below 770 psi (5309 kPa) and shuts off when brake pressure reaches 950 psi (6550 kPa) (old and new configuration). Pump motor starts when brake pressure drops below 1100 psi (7584 kPa) and shuts off when brake pressure reaches 1300 psi (8963 kPa) (new configuration with brake modulation and new configuration with brake modulation and enhanced parking brake). Low brake pressure is an indication of air in brake lines.

4. Turn MASTER switch (1) ON and charge brake system until pump motor stops (770–950 psi or 1100–1300 psi). If pump motor does not stop, repeat steps 1 through 4 until no air is detected in the brake lines.
5. If pump motor does not stop after repeating steps 1 through 4, notify unit maintenance.

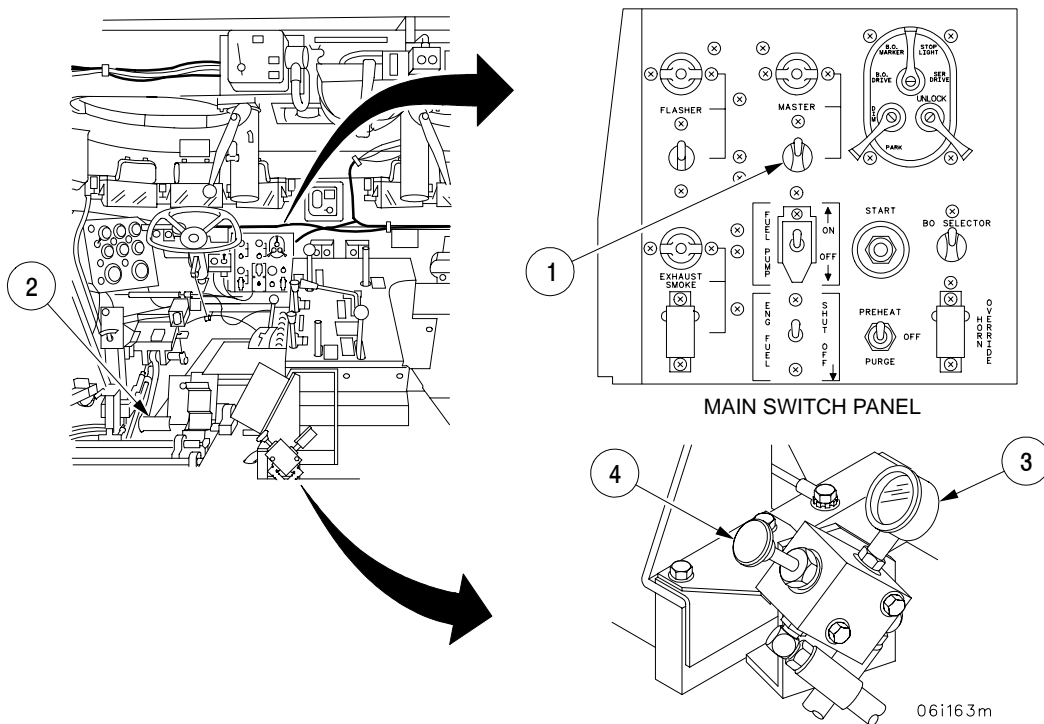

06i163m

END OF TASK

EXTREME COLD WEATHER MAINTENANCE

0123 00**THIS WORK PACKAGE COVERS:**Extreme Cold Weather Maintenance

INITIAL SETUP:**Personnel Required**

Three

ReferencesWP 0105 00
DA Form 2404
FM 9-207
FM 23-65
TM 9-1005-213-10

1. Special care in cleaning and lubricating the vehicle must be taken where extremes in temperature, humidity, and terrain conditions exist. Good care of vehicle ensures proper operation and functioning. It also guards against excessive wear of the working parts and deterioration of the materiel. Approved storage and handling instructions for lubricants and fuels should be followed.
2. Refer to WP 0105 00, Table 6 for lubrication instructions. These services should be done often during extremely cold and hot weather, prolonged travel periods, fording, continued exposure to wet or salty air, operation in sand, dust, mud, or for short start-and-stop operation periods. Any of these conditions may reduce the effectiveness of the lubricants.
3. When repeated failure of the materiel results from exposure to extreme conditions, report the problem on DA Form 2404 and notify unit maintenance.

NOTE

Make frequent inspections of inactive vehicles.

4. Batteries.

Extreme cold causes batteries to freeze and prevents them from furnishing enough power for engine starts. FM 9-207 gives information about the effects of cold weather on batteries. Have unit maintenance remove batteries from vehicle and store them in a warm place whenever the vehicle is not used for long periods.

5. Tracks and Suspension.

Park the vehicle on a footing of planks or brush to prevent tracks from freezing to the ground. Chock if necessary. Clean mud, snow and ice from tracks and suspension as soon as possible. Refer to FM 9-207 for the effects of cold weather on the tracks and suspension.

6. Canvas Covers and Tarpaulins.

Canvas covers and tarpaulins are hard to use in cold weather. Whenever possible tarpaulins should be warmed and unfolded in heated areas. Clean the vehicle of snow, ice and mud before covering. Cover and shield the vehicle, but keep ends of cover off the ground to prevent them from freezing. Always cover the rear deck of the vehicle to keep snow out of the engine compartment.

**WARNING****7. Metal Parts.**

Metal parts become more brittle and cannot take shock loads at arctic temperatures. Make frequent inspections of metal areas. Remove corrosion from exterior metal surfaces with abrasive paper or cloth and apply a protective coating of paint, oil or suitable rust preventative.

8. Plastic and Rubber Parts.

Any parts made of plastic or rubber materials must be handled carefully. These become brittle in cold weather and may break due to vibration or handling. To prevent insulation from cracking and causing short circuits, warm plastic or rubber insulation cables before bending and be sure all cables are secured in the vehicle.

9. Vision devices.

Do not expose vision devices to sudden changes in temperature. Equipment used outside at low temperatures should stay outside to avoid fogging.

10. Armament.**CAUTION**

Do not allow weapon's recoil mechanism to freeze. Severe damage to the weapon might result if the recoil mechanism is frozen.

- Keep bore of machine gun and firing mechanism covered when not in use to prevent entrance of snow.
- Clean bore of the machine gun while barrel is still warm, if possible.
- The recoil mechanism may stick unless it is exercised frequently. Refer to FM 23-65 or TM 9-1005-213-10 for methods of exercising.

END OF TASK

EXTREME HOT WEATHER MAINTENANCE**0124 00****THIS WORK PACKAGE COVERS:**

Extreme Hot Weather Maintenance

INITIAL SETUP:**Materials/Parts**

Lubricating oil, preservative (item 20, WP 0135 00)
 Compound, Silicone (item 38, WP 0135 00)
 Cloth, Abrasive Crocus (item 7, WP 0135 00)

References

WP 0135 00
 TM 9-1005-213-10

Personnel Required

Three

1. Batteries.

- Electrolyte level - In hot climates, check electrolyte level daily.
- Specific gravity - Batteries should have a weaker electrolyte in hot areas (1.200 to 1.225 at full charge). Have specific gravity level checked by unit maintenance.
- Self-discharge - A battery will self-discharge faster if left standing for long periods in high temperatures. If the vehicle is parked for several days, have the batteries removed by unit maintenance and stored in a cool place.

2. Hull and Crew Compartment.

In hot, damp areas, corrosion will occur on all parts of the materiel. It will appear as rust and paint blisters on metal surfaces and mildew, mold, or fungus growth on fabric and glass. Protect all unfinished, exposed metal surfaces with a film of preservative lubricating oil. Cables and terminals should be protected by silicone compound.

**WARNING**

Frequently inspect inactive vehicles. Remove corrosion from exterior with abrasive paper or cloth and apply a protective coating of paint, oil or suitable rust preventative.

3. Armament.

Inspect parts often for moisture or corrosion. Thoroughly dry all exposed, unpainted surfaces such as machine gun bore, breech and firing mechanisms, and oil as prescribed in TM 9-1005-213-10. In dry, dusty, or sandy areas, leave exposed surfaces, such as recoil slides, free of oil or preservative. Combining the oil with sand makes an abrasive paste far more damaging than no oil at all. At other times keep these surfaces lubricated to prevent rusting.

4. Vision Devices.

Inspect parts for moisture, corrosion, or fungus growth. In dry, dusty or sandy areas, keep exposed optical surfaces protected from blowing sand and dirt.

END OF TASK

MAINTENANCE AFTER FORDING**0125 00****THIS WORK PACKAGE COVERS:**

Maintenance After Fording

INITIAL SETUP:**Tools and Special Tools**

Lubricating oil (item 20, WP 0135 00)

Personnel Required

Three

References

WP 0135 00

WP 0105 00

WP 0053 00

WP 0116 00

TM 9-1005-213-10

Although the vehicle housings are sealed to prevent leakage, water may enter, especially during submersion. The following services should be performed when the vehicle is exposed to partial or total submersion, especially in salt water.

**WARNING**1. Hull and Cab.

Drain and clean hull. Clean exposed surfaces and touch up with paint where necessary. Coat unpainted metal parts with preservative lubricating oil.

2. Engine and Transmission.

Check the lubricant in the engine and transmission. If water or signs of water are present, have unit maintenance drain and refill the assemblies with the correct lubricant. Refer to WP 0105 00.

3. Suspension.

Clean and lubricate all parts of the suspension as specified in WP 0105 00. Force lubricant generously into each lubrication fitting to force out water.

4. Batteries.

Check the batteries' electrolyte level to be sure that no water entered through the vent caps. This is important if the vehicle was submerged in salt water. Notify unit maintenance to check specific gravity and service batteries.

5. Electrical Connections.

Check all electrical connections for corrosion. Notify unit maintenance to clean or repair electrical connectors.

6. Auxiliary Power Unit.

Check oil level for water. If water or signs of water are present, have unit maintenance drain and refill with correct lubricant. Refer to WP 0105 00. Start APU (WP 0053 00), run under load until engine and generator assembly are free from residual moisture in and around the unit.

MAINTENANCE AFTER FORDING - CONTINUED

0125 007. Fuel system.

Drain fuel tanks of any accumulated water.

8. Air Cleaners.

If water is found in the air cleaner, clean and dry the filter element (WP 0116 00).

9. Condensation.

The sudden cooling of the warm interior air upon submersion might cause condensation of moisture within instruments. A period of exposure to warm air after fording should eliminate this condition.

10. Vision Devices.

If moisture has entered optical instruments, turn them in to unit maintenance for repair at the earliest opportunity.

11. Armament.

Perform authorized lubrication services on the .50 caliber machine gun (TM 9-1005-213-10). Assemblies which require disassembly for proper lubrication must be disassembled, dried and lubricated as soon as possible. Notify unit maintenance personnel so that complete disassembly, cleaning and lubrication can be accomplished as soon as possible.

END OF TASK

MAINTENANCE AFTER OPERATION ON UNUSUAL TERRAIN**0126 00****THIS WORK PACKAGE COVERS:**

Maintenance After Operation On Unusual Terrain

INITIAL SETUP:**Personnel Required**

Three

References

WP 0105 00

WP 0116 00

1. Mud.

Clean and lubricate all parts as soon as possible after operation in mud (WP 0105 00).

2. Air Cleaners.

If water is found in the air cleaner, clean and dry the filter element (WP 0116 00).

3. Sand and Dust.

Operation in dusty or sandy areas requires more frequent cleaning and servicing of filters to prevent dust entering engine, transmission, fuel system, and hydraulic system. Dust build-up on major components increases chance of entry into internal areas, and interferes with adequate cooling. Pay particular attention to the following service areas:

- Lubricate vehicle as specified in WP 0105 00, shortening service interval as required.
- Carefully clean all areas around lubrication fittings, fill ports, dipsticks, breathers, and filters, before servicing or inspecting.
- Have unit maintenance service engine oil filters, fuel filters, transmission oil filter, and hydraulic oil filters.
- Check and clean door hinges, fuel filler protective cap and vent, spade lock, boom travel lock.
- Monitor brake and steering operation for binding/failure to release. Report malfunctions to unit maintenance personnel.

END OF TASK

CALIBER .50 MACHINE GUN AND MOUNT MAINTENANCE**0127 00****THIS WORK PACKAGE COVERS:**

Machine Gun Removal and Installation, Machine Gun Mount Removal and Installation

INITIAL SETUP:**Personnel Required**

Three

References

FM 23-65

TM 9-1005-213-10

For service, refer to FM 23-65 and TM 9-1005-213-10. Perform the maintenance and lubrication procedures authorized at crew level maintenance.

MACHINE GUN REMOVAL AND INSTALLATION

1. Pull two locking pins (1).
2. Lift machine gun from mount (2) and remove.
3. Position machine gun in mount (2).
4. Install two locking pins (1).

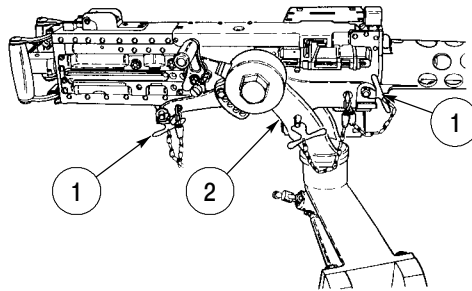
**MACHINE GUN MOUNT REMOVAL AND INSTALLATION**

1. Remove machine gun in accordance with this work package.
2. Loosen traverse lock (1).
3. Lift mount (2) from commander's cupola support bracket (3).
4. Position mount (2) on commander's cupola support bracket (3).
5. Tighten traverse lock (1).
6. Install machine gun if desired in accordance with this work package.

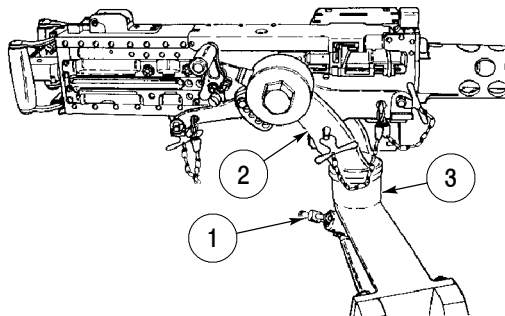
**END OF TASK**

WELDING EQUIPMENT MAINTENANCE**0128 00****THIS WORK PACKAGE COVERS:**

Oxygen Equipment Replacement, Acetylene Cylinder Replacement

INITIAL SETUP:**Tools and Special Tools**

Adjustable wrench (item 40, Table 2, WP 0133 00)

References

WP 0133 00

Personnel Required

Three

OXYGEN CYLINDER REPLACEMENT

1. Remove quick-release pin (1) and open guard (2).
2. Loosen two nuts (3) and open two strap assemblies (4).
3. Remove cylinder (5) from two strap assemblies (4).
4. Lay cylinder (5) between two strap assemblies (4).
5. Close two strap assemblies (4) and tighten two nuts (3).
6. Close guard (2) and install quick-release pin (1).

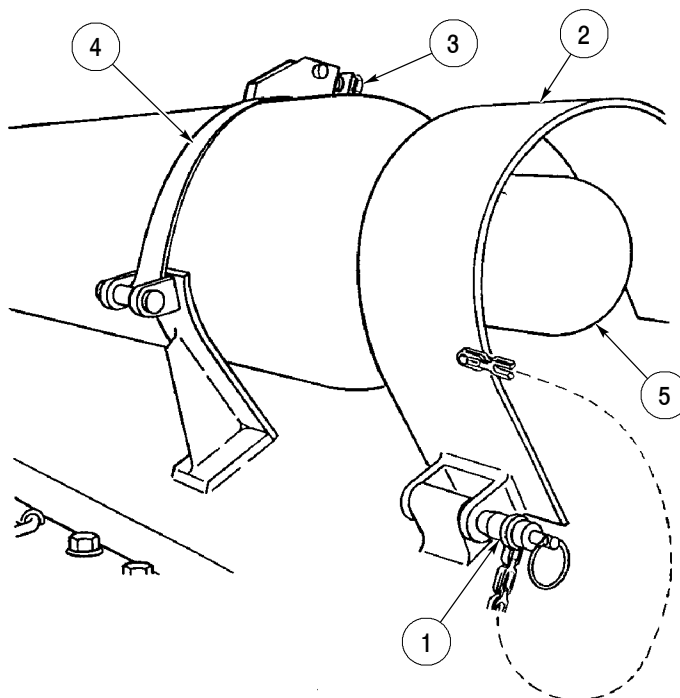

18i247m

WELDING EQUIPMENT MAINTENANCE - CONTINUED**0128 00****ACETYLENE CYLINDER REPLACEMENT**

1. Loosen wing nut (1) on top rear of hinge assembly (2).
2. Swing hinge assembly (2) (containing gas-particulate filter and portable fire extinguisher) out of the way.
3. Open acetylene stowage cabinet door.
4. Remove valve outlet (3) from cylinder (4).
5. Cap cylinder with safety cap (5).
6. Remove four screws (6), four lockwashers (7), and two brackets (8).
7. Remove acetylene cylinder (4) from vehicle.
8. Install new acetylene cylinder (4) in acetylene cylinder stowage cabinet.
9. Remove safety cap (5) from cylinder (4).
10. Install two brackets (8), four lockwashers (7) and four screws (6).
11. Connect valve outlet (3) to cylinder (4).
12. Close cabinet door.
13. Swing hinge assembly (2) back into position and tighten wing nut (1).

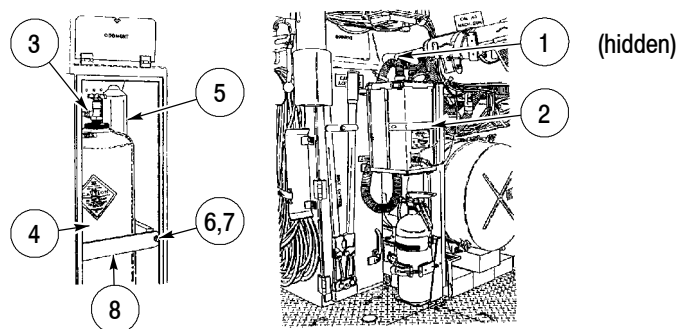
**END OF TASK**

GAS-PARTICULATE FILTER UNIT**0129 00****THIS WORK PACKAGE COVERS:**

Gas-Particulate Filter Change Requirements, Particulate Filter Change Requirements

**GAS-PARTICULATE FILTER CHANGE REQUIREMENTS**

Notify unit maintenance to replace the gas-particulate filter of the filter unit when any one of the following conditions exists:

1. Physical damage.
2. Water-soaked.
3. Low airflow to the masks which is not found to be caused by clogged particulate filter, incorrect hose connections or low electrical power.
4. 5,000-mile (8,045 km) vehicle overhaul (peacetime operations).
5. 10,000 hours of vehicle operation (wartime operations), no chemical agents used.
6. 1,500 hours (approximately 5 months) of vehicle operation (wartime operations), chemical agents used.
7. After each NBC attack (as soon as possible).
8. At beginning of combat conditions and when the use of NBC agents is expected.

PARTICULATE FILTER CHANGE REQUIREMENTS

Notify unit maintenance to replace the M13 particulate filter when any one of the following conditions exists:

1. Physical damage.
2. The M12A1 gas filter is changed.
3. The particulate filter becomes clogged, resulting in not enough air flow to each crew member station.

END OF TASK

COMMUNICATIONS SYSTEM**0130 00****THIS WORK PACKAGE COVERS:**

Preventive Maintenance, Cleaning, Reference

INITIAL SETUP:**Materials/Parts**

Dry-cleaning solvent (item 11, WP 0135 00)
 Detergent, general purpose (item 10, WP 0135 00)
 Cleaning cloth
 Brush

Personnel Required

Three

References

WP 0105 00
 WP 0135 00
 TM 11-5820-890-10-1 (AN/VRC 90A)
 TM 11-5820-890-10-2 (AN/VRC 90A)
 TM 11-5830-340-12 (AN/VIC-1(V))
 TM 11-5830-263-10 (AN/VIC-3(V))

PREVENTIVE MAINTENANCE

Preventive maintenance checks and services (WP 0105 00) will be done daily on all radio and intercommunication equipment. This maintenance will also be done when:

1. Equipment is first installed.
2. Equipment is reinstalled after removal for any reason.
3. At least once a week if equipment is in stand-by mode.

CLEANING

1. Inspect the outside surfaces of equipment for dirt, grease, dust or fungus.
2. Remove dust, fungus and loose dirt on the cases and connectors with a soft, clean cloth or brush.

**WARNING**

3. Use dry-cleaning solvent on a cloth to remove grease and dirt from cases.
4. Clean the front panels and knobs with a soft, clean cloth. If dirt is hard to remove, dampen cloth with water. Use a mild soap if necessary.

REFERENCE

Refer to the following Technical Manuals for further information on the radio and intercommunication equipment supplied with the M88A2:

1. TM 11-5820-890-10-1 or TM 11-5820-890-10-2 for radio set AN/VRC 90A.
2. TM 11-5830-340-12 for intercommunication set AN/VIC-1(V) or TM 11-5830-263-10 for intercommunication set AN/VIC-3(V).

END OF TASK

M239 SMOKE GRENADE SYSTEM

0131 00

THIS WORK PACKAGE COVERS:

Record and Report Forms, Cleaning, Shipping and Storage Requirements

INITIAL SETUP:

Materials/Parts

- Cleaning compound, rifle (item 6, WP 0135 00)
- Detergent, general purpose (item 10, WP 0135 00)
- Lubricating oil (item 28, WP 0135 00)
- Wiping rags (item 45, WP 0135 00)

Personnel Required

Three

References

- DA PAM 738-750
- AR 385-40
- AR 75-1
- TM 3-250
- TM 1300-200-12
- FM 5-250
- TM 43-0139
- WP 0135 00

RECORD AND REPORT FORMS

1. Equipment maintenance forms and procedures are prescribed in DA PAM 738-750.
2. Report accidents involving injury to personnel or damage to material in accordance with AR 385-40.
3. Report accidents or malfunctions in combat or training in accordance with AR 75-1.
4. Refer to TM 3-250, TM 1300-200-12, and FM 5-250 for destruction instructions for grenade launcher.
5. Refer to TM 43-0139, Painting Instructions for Field Use, for painting instructions on the grenade launcher.

CLEANING

NOTE

Do not use wire brush to clean barrels of dischargers.

1. Clear debris from discharger barrels.
2. See that drain holes in barrels are clear by inserting a stiff wire.
3. Clean barrels with rifle cleaning compound or soap and water as applicable.
4. Wipe with a clean, dry cloth. Be sure that no residue remains around the tip plugs which are located at bottom center in each barrel.
5. Lightly apply lubricant to pins in each barrel.
6. After cleaning and after missions, install canvas covers to protect discharger barrels from dust, grit and debris.

SHIPPING AND STORAGE REQUIREMENTS

<u>Requirements</u>	<u>Designation</u>
Storage Compatibility Group	G
Quality Distance Class	1.4
DOT* Class	Explosive C
DOT* Marking Label	Explosive C
DOT* Marking	Smoke Grenade Handle Carefully Keep Fire Away

*Department of Transportation

END OF TASK

CHAPTER 5

SUPPORTING INFORMATION

REFERENCES

This work package lists all forms, field manuals, technical manuals and miscellaneous publications referenced in this manual.

FORMS

Preventive Maintenance Schedule and Record DD Form 314

Product Quality Deficiency Reports SF Form 368

Recommended Change to Publications DA Form 2028

Recommended Changes to Equipment Technical Publications DA Form 2028-2

Report of Deficiency (ROD) SF Form 364

US Army Accident Report DA Form 285

Equipment Inspection and Worksheet DA Form 2404

Equipment Log Assembly DA Form 2408

Equipment Modification Record DA Form 2408-5

Equipment Control Record DA Form 2408-9

Accident Identification Card DD Form 518

Motor Equipment Utilization Record DD Form 1970

Operator Report on Motor Vehicle Accidents SF Form 91

Maintenance Request DA Form 2407

FIELD MANUALS

First Aid for Soldiers FM 21-11

NBC Protection FM 3-4

NBC Decontamination FM 3-5

Explosives and Demolitions FM 5-250

Vehicle Recovery Operations FM 9-43-2

Manual for the Tracked Combat Vehicle Driver FM 21-306

Browning Machine Gun, Caliber .50, Heavy Barrel, M2 FM 23-65

NBC Contamination Avoidance FM 3-3

Basic Cold Weather Manual FM 31-70

Mountain Operations FM 90-6

Operations in the Arctic FM 31-71

Driver Selection, Training and Supervision FM 21-17

Operation and Maintenance of Ordnance Material in Extreme Cold Weather
0° to -65° F FM 9-207

REFERENCES - CONTINUED

0132 00

TECHNICAL BULLETINS

- Warranty Technical Bulletin: Recovery Vehicle, Heavy, Full-tracked: M88A2 TB 9-2350-292-15
- Color, Markings and Camouflage Painting of Military Vehicles, Construction Equipment, and Material Handling Equipment TB 43-0209
- Munitions, Suspended or Restricted TB 9-1300-385
- The Army Oil Analysis Program TB 43-0210

TECHNICAL MANUALS.

- Operator's, Organizational, Direct Support, and General Support Maintenance Manual for Lead-Acid Storage Batteries TM 9-6140-200-14
- Procedures for Destruction of Equipment to Prevent Enemy Use TM 750-244-6
- Painting Instructions for Field Use TM 43-0139
- Operator's Manual: Machine Gun, Caliber .50, Browning M2 Heavy Barrel TM 9-1005-213-10
- Operator's and Organizational Maintenance Manual for Grenades TM 9-1330-200-13
- Ammunition, General TM 9-1300-200
- Organizational, Field and Depot Maintenance Repair Parts List for Wrench, Impact, Hydraulic (5130-00-790-2284), Change 1 TM 9-5130-338-12&P
- SINGGARS ICOM Ground Radio Operator's Pocket Guide for Manpack Radio AN/PRC-119A (NSN 5820-01-267-9482) (EIC: L2Q) Short Range Vehicular Radio AN/VRC-87A (5820-01-267-9480) (EIC: L22) Short Range Vehicular Radio with Single Radio Mount AN/VRC-87C (5820-01-304-2045) (EIC: GDC) Short Range Vehicular Radio with Dismount AN/VRC (5820-01-267-9481) (EIC: L23) Short Range Vehicular Radio with Dismount and Single Radio Mount AN/VRC-88C (5820-01-304-2044)(EIC: GDD) Short Range/Long Range Vehicular Radio AN/VRC-89A (5820-01-267-9479) (EIC: L24) Long Range Vehicular Radio AN/VRC-90A (5820-01-268-5105) (EIC: L25) Short Range/Long Range Vehicular Radio with Dismount AN/VRC-91A (5820-01-267-9478) (EIC: L26) Long Range/ Long Range Vehicular Radio AN/VRC-92A (5820-01-267-9477) (EIC: L27) TM 11-5820-890-10-2
- Operator's Manual for SINGGARS Ground Combat Net Radio, ICOM Manpack Radio AN/PRC-119A (NSN 5820-01-267-9482) (EIC: L2Q) Short Range Vehicular Radio AN/VRC-87A (5820-01-267-9480) (EIC: L22) Short Range Vehicular Radio with Single Radio Mount AN/VRC-87C (5820-01-304-2045) (EIC: GDC) Short Range Vehicular Radio with Dismount AN/VRC-88A (5820-01-267-9481) (EIC: L23) Short Range Vehicular Radio with Dismount and Single Radio Mount AN/VRC-88C (5820-01-304-2044) (EIC: GDD) Short Range/Long Range Vehicular Radio AN/VRC-89A (5820-01-267-9479) (EIC: L24) Long Range Vehicular Radio AN/VRC-90A (5820-01-288-5105) (EIC: L25) Short Range/Long Range Vehicular Radio with Dismount AN/VRC-91A (5820-01-267-9478) (EIC: L26) Long Range/ Long Range Vehicular Radio AN/VRC-92A (5820-01-267-9477) (EIC: L27) TM 11-5820-890-10-1
- Operator's and Organizational Maintenance Manual for Intercommunication Set, AN/VIC-1(V) (NSN 5830-00-856-3273): Control Intercommunication Set, C-10456/VRC 5830-01-082-0804, C-108680/VRC and Amplifier, Audio Frequency, AM7046/VRC TM 11-5830-340-12

REFERENCES - CONTINUED

0132 00

TECHNICAL MANUALS - CONTINUED

Operator's Manual for Vehicular Intercommunications Systems AN/VIC-3(V), including Control Indicator CD-82/VRC (NSN 5895-01-382-3221), Control Intercommunication set C-12357/VRC, (NSN 5830-01-382-3218), Control Intercommunication set C-1258/VRC (NSN 5830-01-382-3209), Interface Unit, Communication Equipment C-12359/VRC (NSN 5895-01-382-3220), Loudspeaker LS-688/VRC (NSN 5965-01-382-3222) TM 11-5830-263-10

Operator's Manual Viewers, Driver's Night Vision AN/VVS-2(V)1A TM 11-5855-249-10

Operators and Unit Maintenance Manual, Driver's Vision Enhancer AN/VAS-5A(V)8 ... TM 11-5855-311-12&P-1

Operator's and Organizational Maintenance Manual Including Repair Parts and Special Tools List for Decontaminating Apparatus, Portable, 14 Liter, M13 TM 3-4230-214-12&P

Operator's Manual for Mask, Chemical-Biological: Aircraft, ABC-M24 and Accessories; Mask, Chemical-Biological, Tank, M25/M25A1 and Accessories TM 3-4240-280-10

Storage, Shipment, Handling, and Disposal of Chemical Agents and Hazardous Chemicals TM 3-250

Operator's Manual: (Hand Receipt), Recovery Vehicle Heavy Full-Tracked, M88A2 TM 9-2350-292-10-HR

REGULATIONS

Accident Reporting and Records AR 385-40

Malfunctions Involving Ammunitions and Explosives AR 75-1

Packaging of Army Materiel for Shipment and Storage AR 746-1

MILITARY SPECIFICATIONS

Grease, Automotive and Artillery MIL-G-10924

Grease, Molybdenum Disulfide MIL-G-21164

Grease, Aircraft and Instrument MIL-G-23827

Hydraulic Fluid, Petroleum Base, Aircraft Missile and Ordnance MIL-H-5606

Hydraulic Fluid, Petroleum Base, Preservative, Hydraulic Equipment MIL-H-6083

Lubricating Oil, ICE, Tactical Service MIL-L-2104

Lubricating Oil, Gear, Multi-Purpose MIL-L-2105

Lubricating Oil, Internal Combustion Engine, Arctic MIL-L-46167

Fire Resistant Synthetic Hydrocarbon Base Hydraulic Fluid MIL-H-46170

Cleaner, Lubricant, Preservative MIL-L-63460

REFERENCES - CONTINUED

0132 00

MISCELLANEOUS PUBLICATIONS

Army Medical Department Expendable/Durable Items CTA 8-100

Expendable Items (Except Medical, Class V, Repair Parts, and Heraldic Items) CTA 50-970

The Army Maintenance Management System (TAMMS), as contained in the
Maintenance Management Update DA PAM 738-750

Hearing Conservation DA PAM 40-501

Application, Installation, Maintenance and Testing of Suppressed Electrical Transient ... SB 11-638

Consolidated Index of Army Publications and Blank Forms DA PAM 25-30

END OF TASK

COMPONENTS OF END ITEM (COEI) AND BASIC ISSUE ITEMS (BII) LISTS**0133 00**

This work package lists components of the end item and basic issue items for the M88A2 Recovery Vehicle to help inventory the items for safe and efficient operation of the equipment.

GENERAL

The Components of End Item (COEI) and Basic Issue Items (BII) List are divided into the following lists:

Components of End Item (COEI). This listing is for information purposes only, and is not authority to requisition replacements. These items are part of the M88A2, but they are to be removed and separately packaged for transportation or shipment. As part of the end item, these items must be with the end item whenever it is issued or transferred between property accounts. Illustrations are furnished to help find and identify the items.

Basic Issue items (BII). These essential items are required to place the M88A2 in operation, operate it, and to do emergency repairs. Although shipped separately packaged, BII must be with the M88A2 during operation and when it is transferred between property accounts. Listing these items is the authority to request/requisition them for replacement based on authorization of the end item by the TOE/MTOE. Illustrations are furnished to help find and identify the items.

EXPLANATION OF COLUMNS IN COEI AND BII LISTS

Column (1) Illus Number - Indicates the callout number used to reference the item in the illustration.

Column (2) National Stock Number - Indicates the National Stock Number assigned to the item which will be used for requisitioning.

Column (3) Description, CAGEC Part Number - Identifies the Federal item name followed by a minimum description when needed. The last line below the description is the CAGEC (Commercial And Government Entity Code) (in parentheses) and the part number.

Column (4) Unit of Issue (U/I) - This column indicates how the item is issued for the National Stock Number shown in column 2.

Column (5) Quantity Required (QTY REQ) - This column lists the quantity of each item required for a complete major item.

**COMPONENTS OF END ITEM (COEI) AND BASIC ISSUE ITEMS (BII) LISTS -
CONTINUED**

0133 00

Table 1 COMPONENTS OF END ITEM LIST

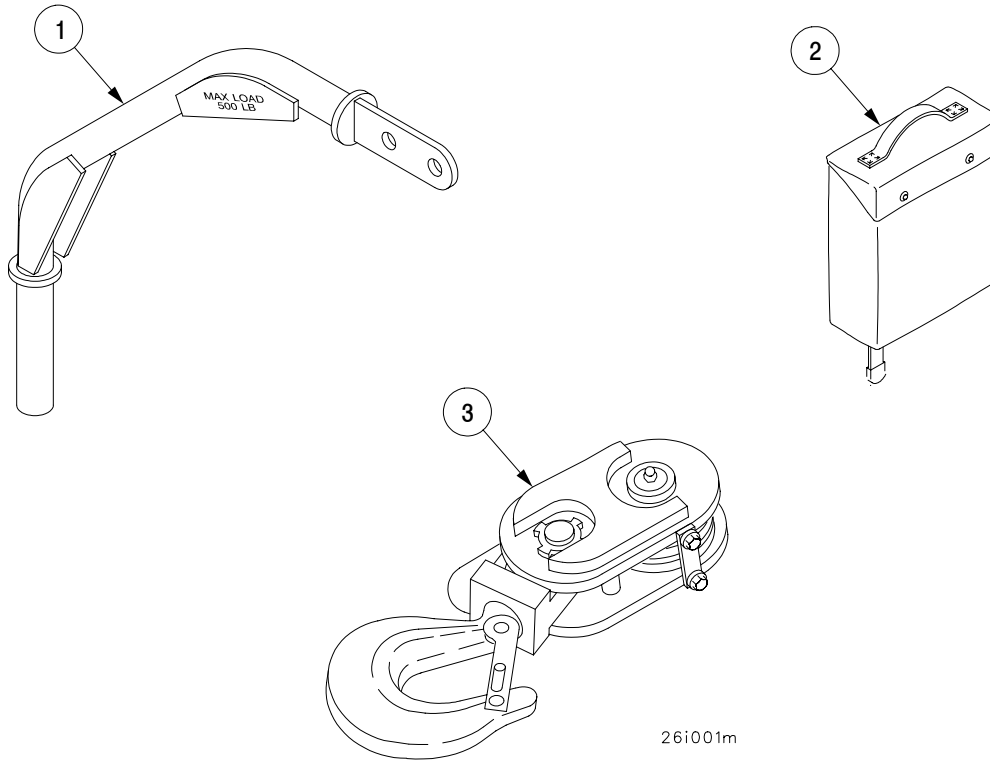

(1) Illus Number	(2) National Stock Number	(3) Description CAGEC and Part Number	(4) U/M	(5) QTY REQ
1	2590-01-431-1220	Auxiliary Boom (500 lb limit) (19207) 12365452	EA	1
2	2540-00-670-2459	Bag, Pamphlet (19207) 11676920	EA	1
3	3940-01-429-8206	Block, Hook, 35-Ton (19207) 12365945	EA	1

COMPONENTS OF END ITEM (COEI) AND BASIC ISSUE ITEMS (BII) LISTS - CONTINUED

0133 00

Table 1 COMPONENTS OF END ITEM LIST - CONTINUED

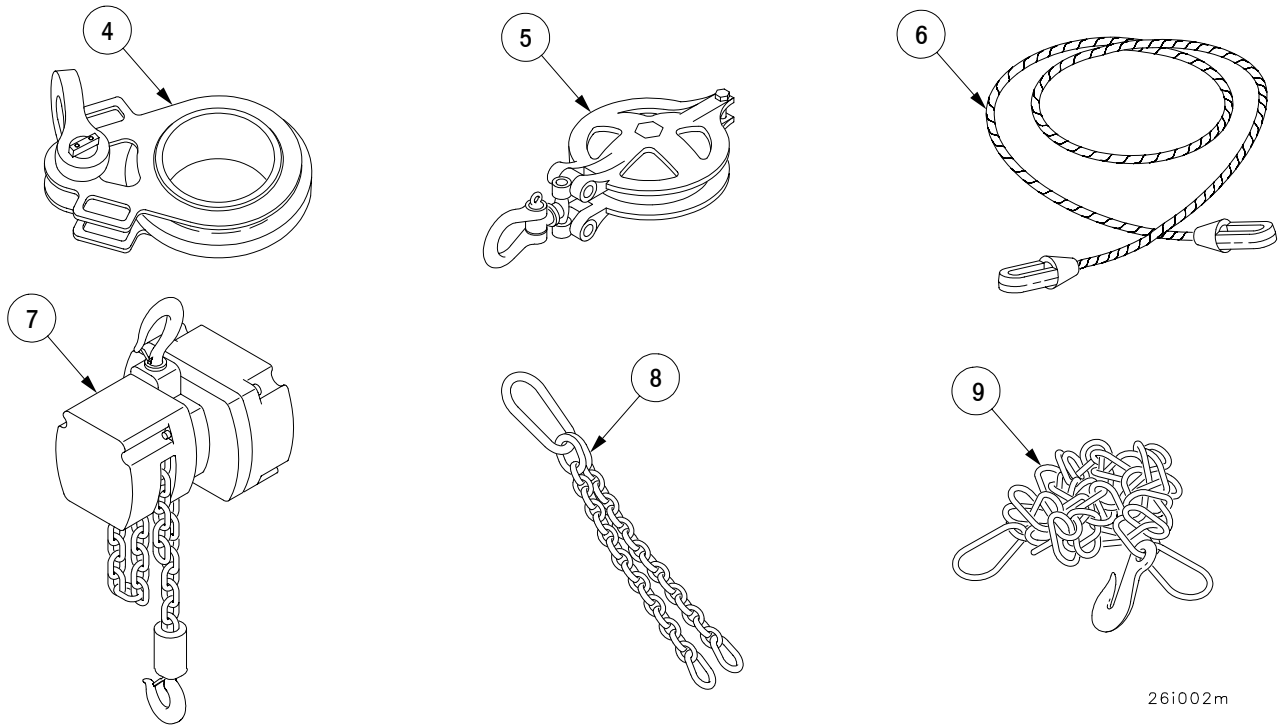

26i002m

(1) Illus Number	(2) National Stock Number	(3) Description CAGEC and Part Number	(4) U/M	(5) QTY REQ
4	3940-01-421-6962	Block, Snatch, 140-Ton (19207) 12364523	EA	1
5	3940-01-435-6371	Block, Snatch, 6.5-Ton (19207) 12366387	EA	1
6	4010-01-421-2793	Cables, Tow, Steel, 1-1/2" dia x 15' long (19207) 12364389	EA	2
7	3950-01-436-4605	Chain Hoist (19207) 12366425	EA	1
8	4010-00-133-6517	Chain, Lifting, Heavy Duty 7/8" (19207) 10929894	EA	1
9	4010-00-473-6166	Chain, Utility, 5/8" V 16' Single Leg w/Hook and End Link (19207) 7077063	EA	3

COMPONENTS OF END ITEM (COEI) AND BASIC ISSUE ITEMS (BII) LISTS - CONTINUED

0133 00

Table 1 COMPONENTS OF END ITEM LIST - CONTINUED

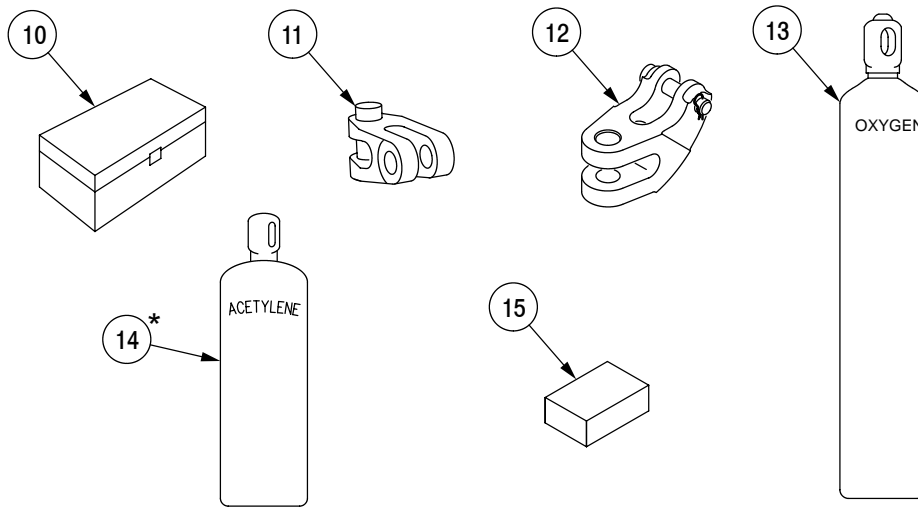

* SOME VEHICLES ARE NOT EQUIPPED WITH ACETYLENE BOTTLES (14).

26i003m

(1) Illus Number	(2) National Stock Number	(3) Description CAGEC and Part Number	(4) U/M	(5) QTY REQ
10	3439-00-383-3634	Cleaner Set, Welding & Cutting Tips, 12 Pieces in Metal Case (00741) 832-4597	EA	1
11	5340-01-267-2908	Clevis, M1 (12322662)	EA	4
	5315-00-539-9174	Pins for Clevis: Pin, Lock (19207) 10929861	EA	6
	5315-00-350-4326	Pin, Locking, Quick Attach	EA	20
12	2540-00-863-3153	Coupler, Drawbar 113 (19207) 10894255	EA	2
13	6830-01-049-5263	Cylinder, Comp. Gas "Oxygen", w/Valve and Cap, Filled (81348) BB-0-925	EA	1
14	6830-00-292-0137	Cylinder, Compressed Gas "Acetylene" (81348) BBA106 (US Army/Egypt)	EA	1
15	5120-00-965-0603	Flint Tip, Friction Ignitor w/Holder 5/Box (22527) 12-010	BX	1

COMPONENTS OF END ITEM (COEI) AND BASIC ISSUE ITEMS (BII) LISTS - CONTINUED

0133 00

Table 1 COMPONENTS OF END ITEM LIST - CONTINUED

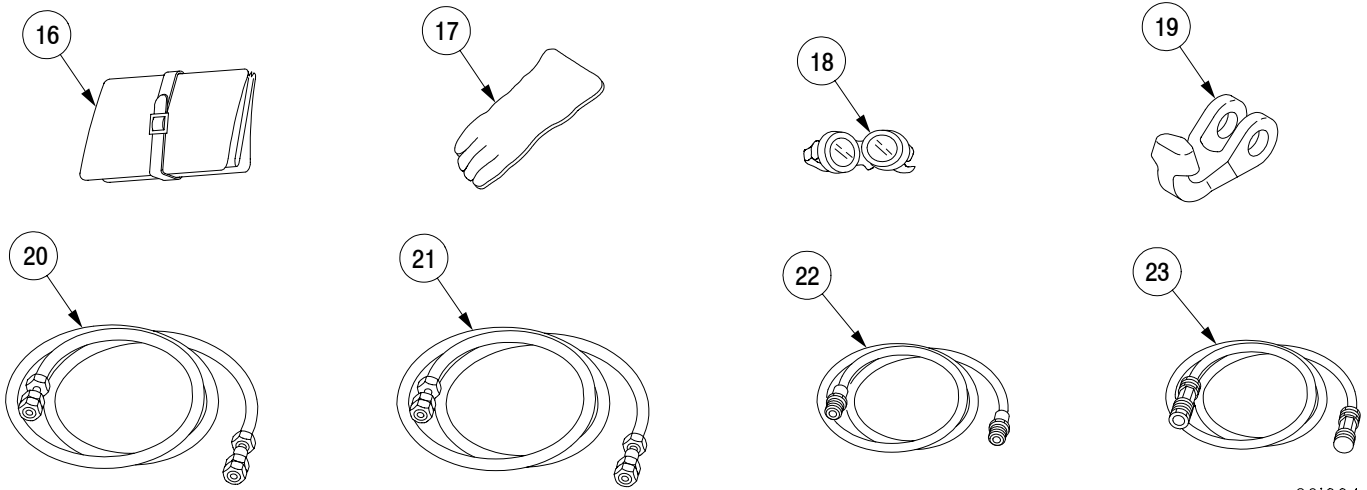

26i004m

(1) illus Number	(2) National Stock Number	(3) Description CAGEC and Part Number	(4) U/M	(5) QTY REQ
16	7530-01-065-0166	Folder Equipment Record (81349) MIL-F-43986	EA	1
17	8415-00-268-7859	Glove, Welding Leather Gauntlet, Size Large (58536) A-A-50022	PR	1
18	4240-00-203-3804	Goggles, Industrial Welding w/Eye Cups, w/o Case (58536) A-A-1814	PR	1
19	2540-00-706-8219	Hook, Tow Cable (19207) 7068219	EA	4
20	4720-00-273-9886	Hose, Gas, "Acetylene" Red, w/Coupling, 5/16" x 50' (US Army, Egypt) (81348) ZZ-H-461	EA	1
21	4720-00-293-7997	Hose, Gas, "Oxygen", Green w/Coupling, 5/16" x 50' (81348) ZZ-H-461	EA	1
22	4720-01-475-6916	Hose, Hydraulic, Impact Wrench a. Hose, Hydraulic, Impact Wrench, 1/2" x 25' (19207) 10867293	EA	2
	4720-00-856-0484	b. Hose, Hydraulic, Impact Wrench, 1/2" x 5' (19207) 10894462	EA	1
23	4720-00-792-9884	Hose, Hydraulic, Impact Wrench a. Hose, Hydraulic, Impact Wrench, 3/8" x 25' (19207) 10867295	EA	2
	4720-00-856-0483	b. Hose, Hydraulic, Impact Wrench, 3/8 x 5' (19207) 10894463	EA	1

COMPONENTS OF END ITEM (COEI) AND BASIC ISSUE ITEMS (BII) LISTS - CONTINUED

0133 00

Table 1 COMPONENTS OF END ITEM LIST - CONTINUED

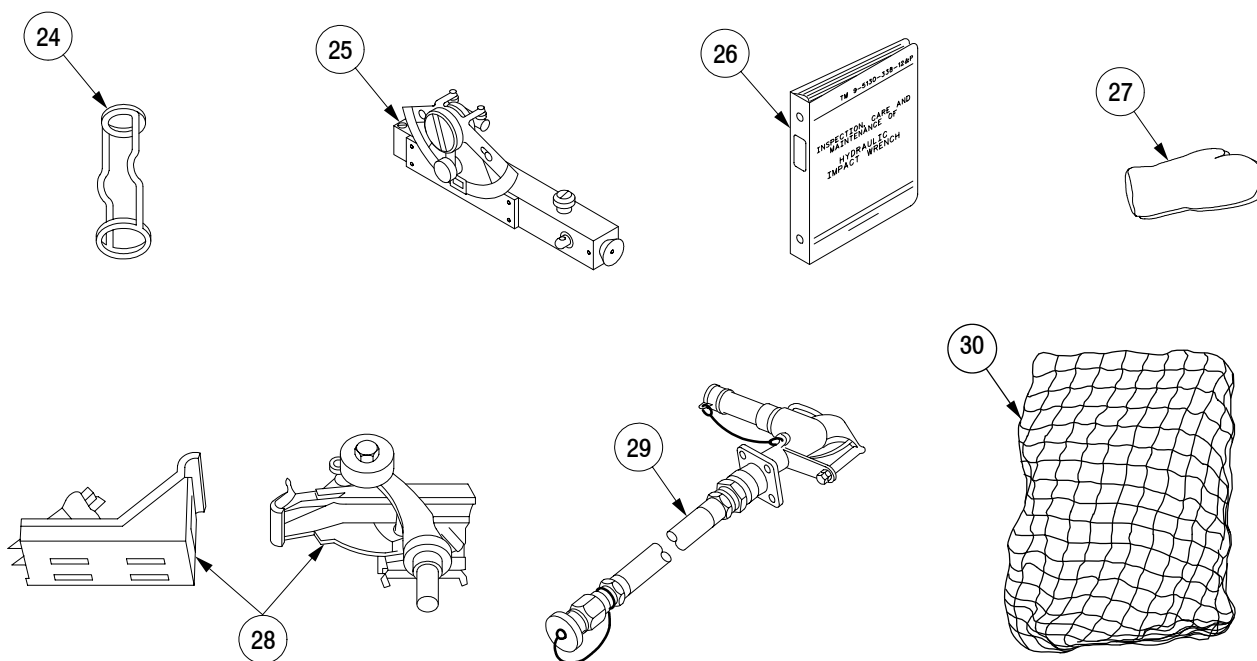

26i004ma

(1) Illus Number	(2) National Stock Number	(3) Description CAGEC and Part Number	(4) U/M	(5) QTY REQ
24	5120-00-965-0326	Igniters, Friction Wire Frame Style, Single Flint (92878) 25000-52	EA	1
25	6675-00-641-3163	Level, Surveying (63848) 40-1750	EA	1
26	TM 9-5130-338-12&P	Manual, Technical, Hydraulic Impact Wrench	EA	1
27	8415-01-092-0039	Mittens, Asbestos, M1942 (81349) MIL-M-11199	PR	2
28	1005-00-836-7286	Mount, Machine Gun Cal .50 (19207) 8367286	EA	1
29	4930-00-861-9982	Nozzle & Fuel Hose Assy (19207) 10884808	EA	1
30	3940-01-477-7074	Net Cargo (098P0) B9154-096-064-2R (US Army)	EA	1

COMPONENTS OF END ITEM (COEI) AND BASIC ISSUE ITEMS (BII) LISTS - CONTINUED

0133 00

Table 1 COMPONENTS OF END ITEM LIST - CONTINUED

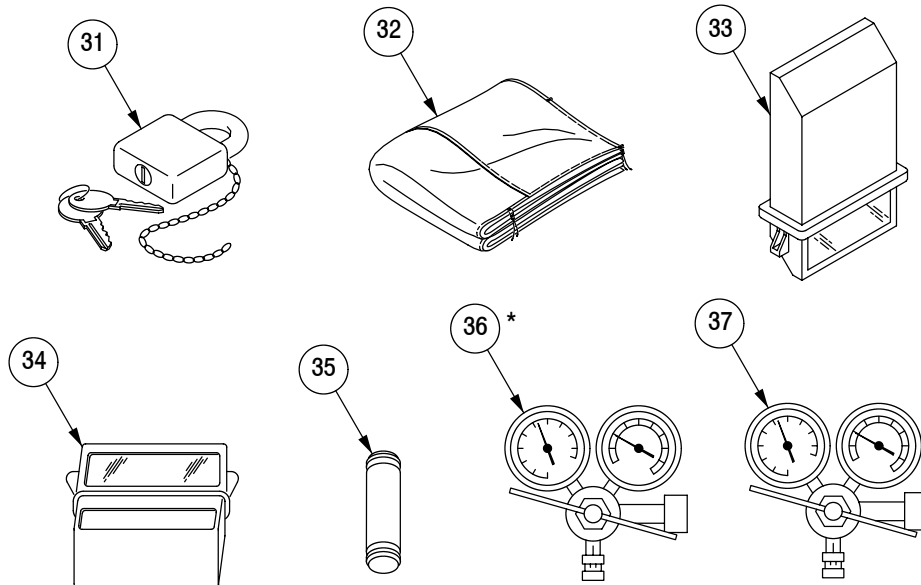

* SOME VEHICLES ARE NOT EQUIPPED WITH PRESSURE REGULATOR ACETYLENE (36).

26i004mb

(1) Illus Number	(2) National Stock Number	(3) Description CAGEC and Part Number	(4) U/M	(5) QTY REQ
31	5340-00-682-1505	Padlock Set, 1-3/4" (5 locks/set) (96906) MS21313-54	EA	2
32	2540-00-653-7589	Paulin, Nylon 12' x 12' (19207) 6537589	EA	1
33	6650-00-704-3549	Periscope, M17 (T24) (Egypt) (Driver, Mechanic and Rigger) (on hull) (56161) 10502011	EA	7
34	6650-01-317-9138	Periscope, M17 (T24) (US Army)	EA	7
	5330-00-900-8006	a. Periscope, M17 (T24) with seal (19207) 12357918	EA	1
		b. Seal only (19207) 10940477	EA	1
35	5315-00-706-9195	Pin, Tow Cable Hook (19207) 7069195	EA	8
36	4820-00-551-1094	Regulator, Pressure, Compressed Gas, Acetylene (63026) 0781-3983	EA	1
37	4820-01-079-8235	Regulator, Pressure, Compressed Gas, Oxygen (17941) RVT 8010 (0-125 PSIG)	EA	1

COMPONENTS OF END ITEM (COEI) AND BASIC ISSUE ITEMS (BII) LISTS - CONTINUED

0133 00

Table 1 COMPONENTS OF END ITEM LIST - CONTINUED

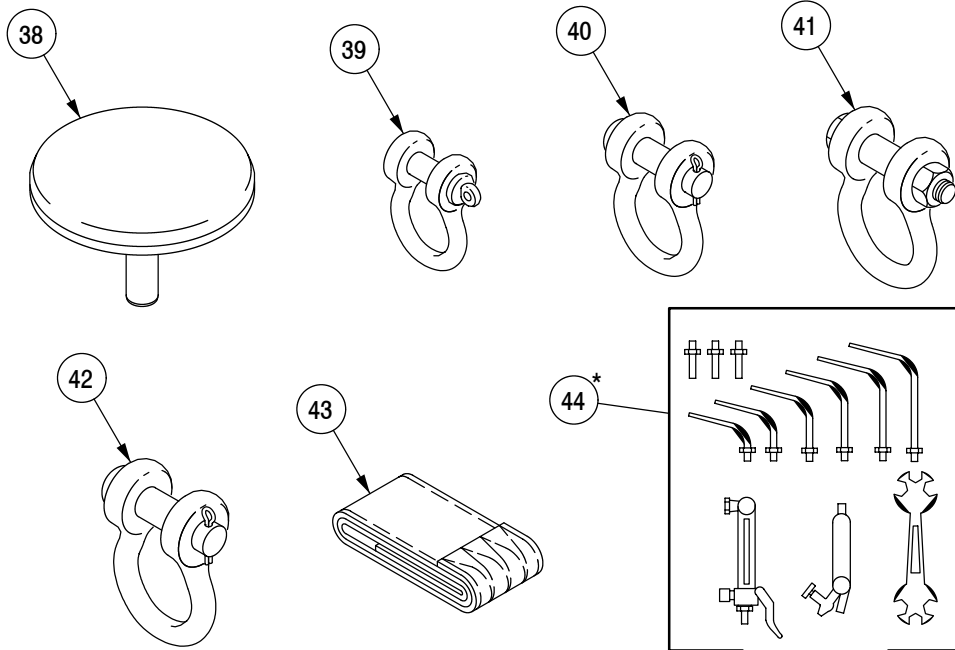

* SOME VEHICLES ARE NOT EQUIPPED WITH CUTTING TORCH SET (44).

26i004mc

(1) Illus Number	(2) National Stock Number	(3) Description CAGEC and Part Number	(4) U/M	(5) QTY REQ
38	2540-00-087-0199	Seat, Vehicular (19207) 8676244	EA	2
39	4030-01-433-2301	Shackle, 12-1/2 Ton (19207) 12364386	EA	6
40	4030-01-420-8863	Shackle, 18 Ton (19207) 12364735	EA	6
41	4030-01-420-8862	Shackle, 50 Ton (19207) 12364385-1	EA	4
42	4030-00-377-1389	Shackle, Anchor, High Strength, 2" dia (81349) MILS24214	EA	4
43	3940-00-675-5002	Sling, Endless 4 ft. PD101-48	EA	1
44	3433-00-294-6743	Torch Set Cutting Male-type Connections, 90° Angle of Head, w/Cutting Attachment, Furnished w/6 Welding Tips (17941) Model U-9838	EA	1

COMPONENTS OF END ITEM (COEI) AND BASIC ISSUE ITEMS (BII) LISTS - CONTINUED

0133 00

Table 1 COMPONENTS OF END ITEM LIST - CONTINUED

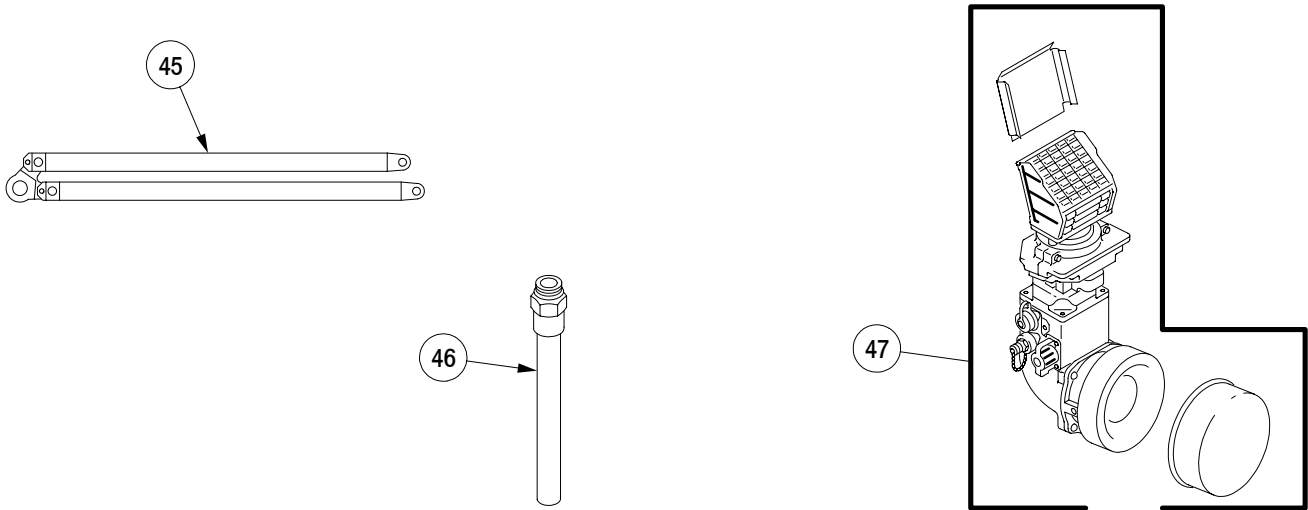

26i007m

(1) Illus Number	(2) National Stock Number	(3) Description CAGEC and Part Number	(4) U/M	(5) QTY REQ
45	2540-01-434-8595	Tow Bar Assy, Heavy Duty (19206) 11580775	EA	2
	2540-01-440-4979	COMPOSED OF: Leg, Tow Bar Adapter (19206) 11580774	EA	4
	2540-01-436-5503	Lunette, Tow Bar (19206) 11580772	EA	2
	5315-01-436-9974	Pin, Cotter (19206) B11580778	EA	4
	5315-01-441-2462	Pin, Large 2" (19206) 11580770	EA	4
	5315-01-440-1402	Pin, Small 1.4" (19206) 11580771	EA	2
	5315-01-439-4752	Pin, Grooved, Headed (19206) 11580766	EA	4
	5315-01-439-4165	Pin, Quick Attach (19206) 11580765	EA	6
46	4710-00-792-9886	Tube, Filler, Nozzle, 34", Long (19207) 10867298	EA	1
47	5855-01-096-0871	Viewer, Passive Night AN-VVS-2(V)1A (05234) AN/VVS-2(V)1A	EA	1

COMPONENTS OF END ITEM (COEI) AND BASIC ISSUE ITEMS (BII) LISTS - CONTINUED

0133 00

Table 1 COMPONENTS OF END ITEM LIST - CONTINUED

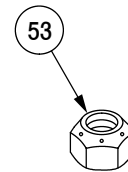
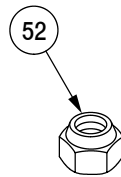
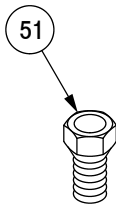
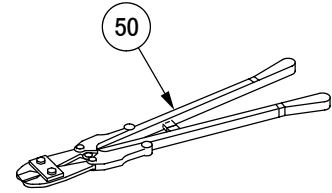
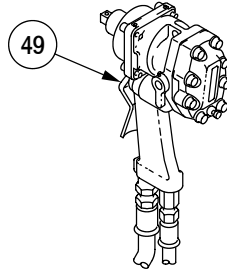
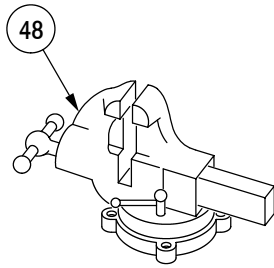

26i008m

(1) Illus Number	(2) National Stock Number	(3) Description CAGEC and Part Number	(4) U/M	(5) QTY REQ
48	5120-00-243-9072	Vise, Bench & Pipe, 5" Jaw & 6" Opening (9W988 or 6698) 330	EA	1
49	5130-01-471-1328	Wrench, Hydraulic, Impact (19207) 12390171	EA	1
50	5110-00-188-2524	Cutter, Bolt, Rigid-Head, Clipper Cut 5/8" Bolt & 9/16" Rod Capacity, 36" (81348) GGG-C-740	EA	1
51	5306-00-538-0854	<u>On Board Spares</u> Bolt, Support Roller (19207) 5380854	EA	12
52	5310-00-225-6408	Nut, Sprocket Bolt (96906) MS51922-53	EA	28
53	5310-01-064-3910	Nut, Roadwheel (19207) 12274570	EA	20

COMPONENTS OF END ITEM (COEI) AND BASIC ISSUE ITEMS (BII) LISTS - CONTINUED

0133 00

Table 1 COMPONENTS OF END ITEM LIST - CONTINUED

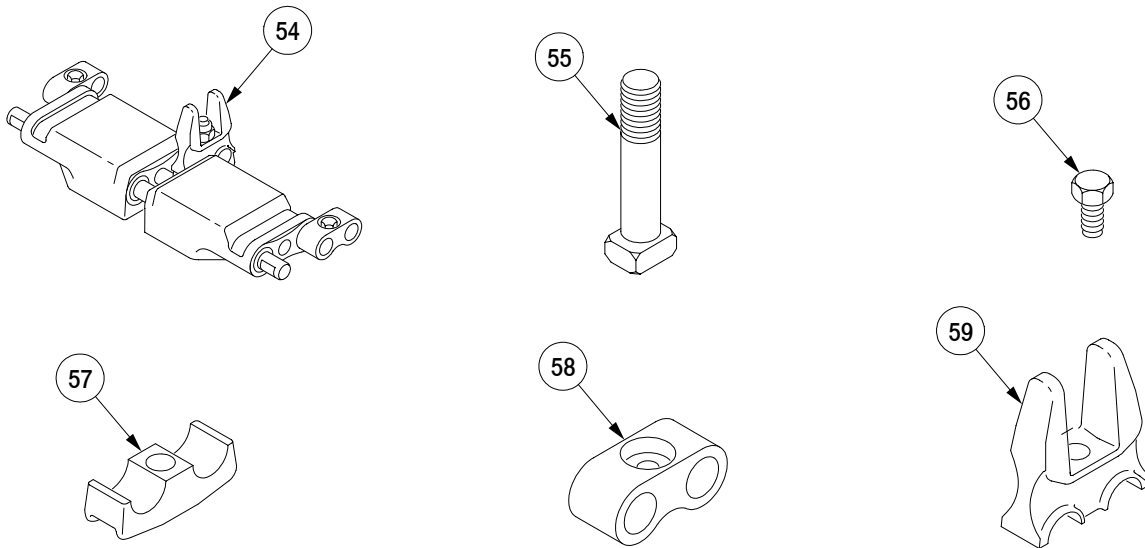

261009m

(1) Illus Number	(2) National Stock Number	(3) Description CAGEC and Part Number	(4) U/M	(5) QTY REQ
54	2530-00-692-9316	Shoe, Track Section (19207) 8705914	EA	6
COMPOSED OF: Items 55 through 62				
55	5306-00-706-9543	Bolt-7069543 (used w/Ctr Guide Cap (19207) 8705894)	EA	1
56	5306-00-695-6188	Bolt; Track Shoe End Conn Wedge (19207) 8382360	EA	2
57	2530-00-692-9314	Cap; Track Shoe Ctr Guide (19207) 8705894	EA	2
58	2530-00-692-9317	Connector; Track Shoe End (19207) 8705919	EA	2
59	2530-00-692-9315	Guide; Track Shoe Center (19207) 8705897	EA	1

COMPONENTS OF END ITEM (COEI) AND BASIC ISSUE ITEMS (BII) LISTS - CONTINUED

0133 00

Table 1 COMPONENTS OF END ITEM LIST - CONTINUED

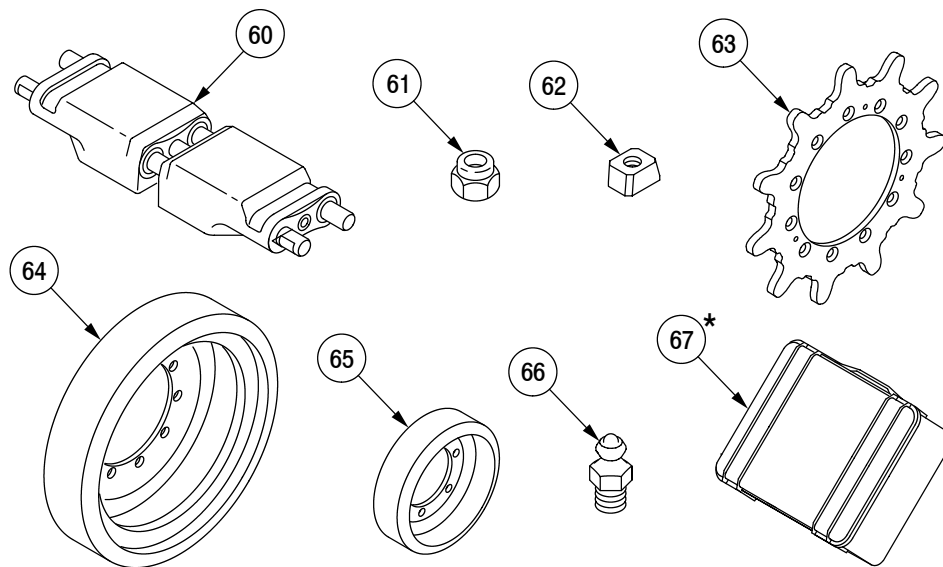

* SOME VEHICLES ARE EQUIPPED WITH DVE (67).

26i010m

(1) Illus Number	(2) National Stock Number	(3) Description CAGEC and Part Number	(4) U/M	(5) QTY REQ
60		Link, Track (19207) 8705899	EA	1
61	5310-00-241-6665	Nut: used w/Ctr Guide Cap 8706894 (96906) MS51943-48	EA	1
62	2530-00-150-5894	Parts Kit, Track Wedge (19207) 5703561	EA	2
63	3020-00-293-5136	Sprocket Wheel (19207) 8705893	EA	2
64	2530-00-701-3976	Wheel, Solid Rubber (19207) 7013976	EA	2
65	2530-00-293-5137	Wheel, Solid Rubber (19207) 8706067	EA	2
66	4730-00-050-4208	Fitting, Lubrication (96906) MS15003-1	EA	10
67		DVE Case Assembly (US Army, USMC) (19207) 12477732	EA	1
	6760-01-491-2706	Composed of: DVE Case (65442) 1550	EA	1
		Monitor, DVE (96214) 3245325-1	EA	1
		Sensor DVE with cable (96214) 3253259-1	EA	1
		Strap (19207) 8690482	EA	1
		Installation Instructions (19207) 12477732	EA	1

COMPONENTS OF END ITEM (COEI) AND BASIC ISSUE ITEMS (BII) LISTS - CONTINUED

0133 00

Table 2 BASIC ISSUE ITEMS LIST

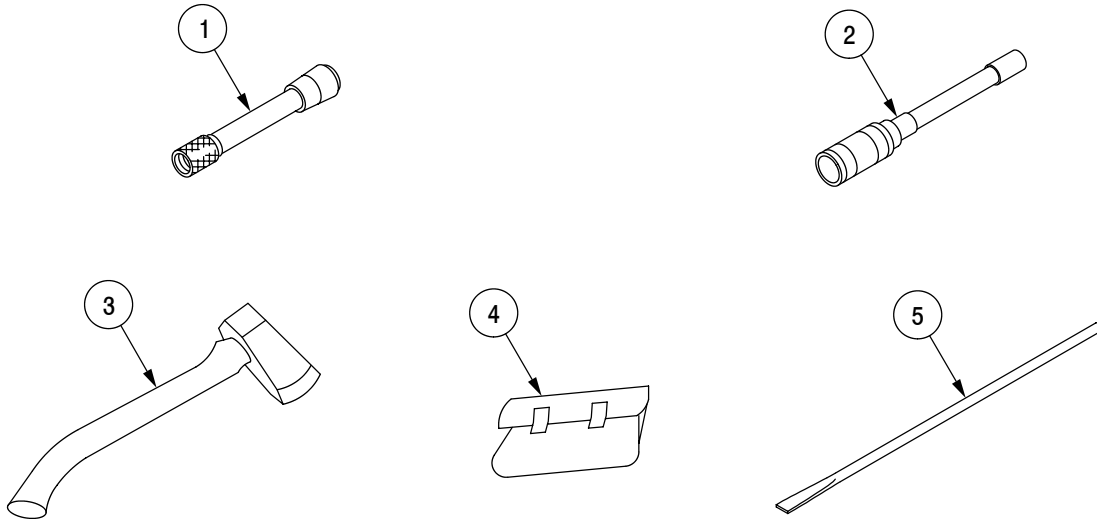

26i011m

(1) Illus Number	(2) National Stock Number	(3) Description CAGEC and Part Number	(4) U/M	(5) QTY REQ
1	4930-00-288-1511	Adapter, Extension, Hydraulic Gun Tube, Flex 12" 1g (36251) 102349	EA	1
2	4930-00-204-2550	Adapter, Thin Stem Gun, Lubr, Sleeve Type (19207) 5349744	EA	1
3	5110-00-293-2336	Axe, Single Bit, 4 lbs (19207) 6150925	EA	1
4	5140-00-473-6256	Bag, Tool, Satchel (19207) 11655979	EA	1
5	5120-00-224-1390	Bar, Crow, Pinch 5 ft long, 1-1/4" wide (19207) 11677049-1	EA	2

COMPONENTS OF END ITEM (COEI) AND BASIC ISSUE ITEMS (BII) LISTS - CONTINUED

0133 00

Table 2 BASIC ISSUE ITEMS LIST - CONTINUED

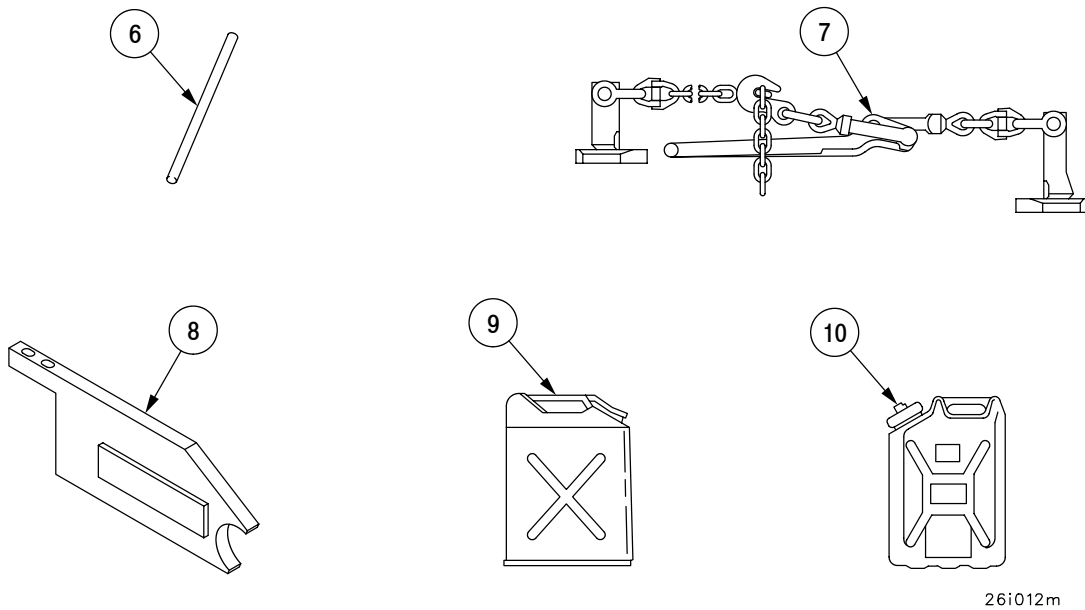

26i012m

(1) Illus Number	(2) National Stock Number	(3) Description CAGEC and Part Number	(4) U/M	(5) QTY REQ
6	5120-00-526-6044	Bar, Pinch	EA	1
7	3990-01-235-0367 3990-01-091-9058	Binder, Track (19207) 12344373 OR Binder, Track (19207) 12285481	EA	1
8	5340-01-460-1440 5340-01-440-6732	Block Assembly, Lockout (19207) 12365794-1 (Left) (19207) 12365794-2 (Right)	EA EA	1 1
9	7240-01-337-5268 7240-01-337-5269	Can, Fuel, Military 5 Gal. (81349) MIL-C-53109 Tan Olive Drab	EA	2
10	7240-00-089-3827	Can, Water, Military 5 Gal. (56161) 10502791	EA	2

COMPONENTS OF END ITEM (COEI) AND BASIC ISSUE ITEMS (BII) LISTS - CONTINUED

0133 00

Table 2 BASIC ISSUE ITEMS LIST - CONTINUED

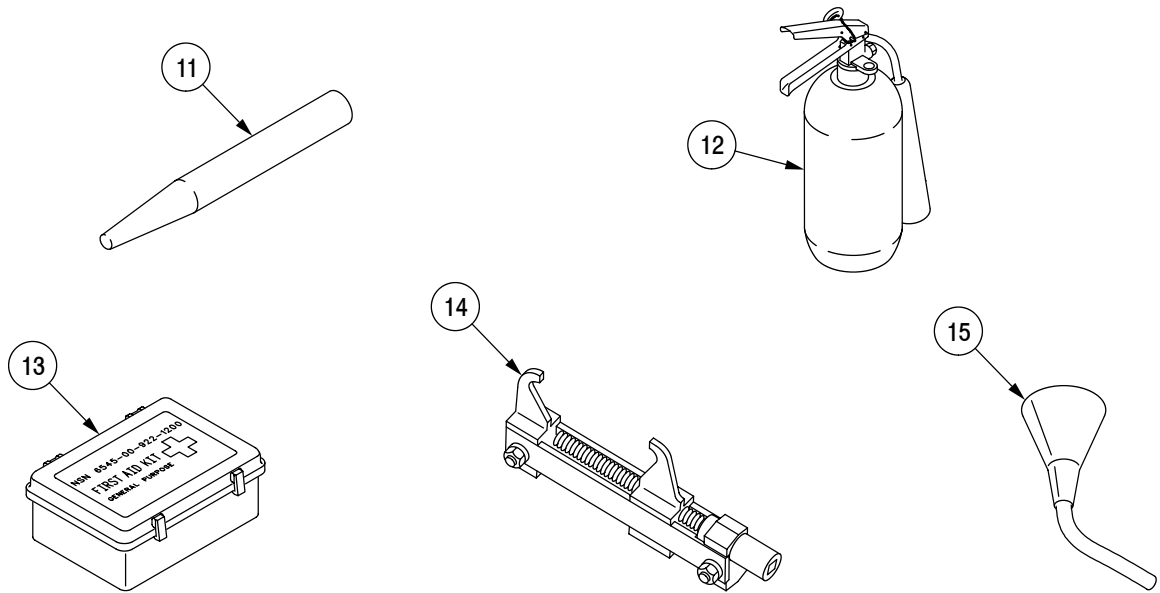

26i013m

(1) Illus Number	(2) National Stock Number	(3) Description CAGEC and Part Number	(4) U/M	(5) QTY REQ
11	5120-00-505-5918	Driftpin	EA	2
12	4210-00-270-4512	Extinguisher, Fire, Portable, 5-lb CO2 (19207) 7359703	EA	2
13	6545-00-922-1200	First Aid Kit, Motor Vehicle, 12 Unit, Size 1 (19207) 11677011	EA	2
14	5120-01-016-2149	Fixture, Track Connect 3/4" Drive 12252120	EA	2
15	7240-00-559-7364	Funnel, S, Zinc-coated, 1 qt (8-inch long flexible tube spout with removable strainer)	EA	1

COMPONENTS OF END ITEM (COEI) AND BASIC ISSUE ITEMS (BII) LISTS - CONTINUED

0133 00

Table 2 BASIC ISSUE ITEMS LIST - CONTINUED

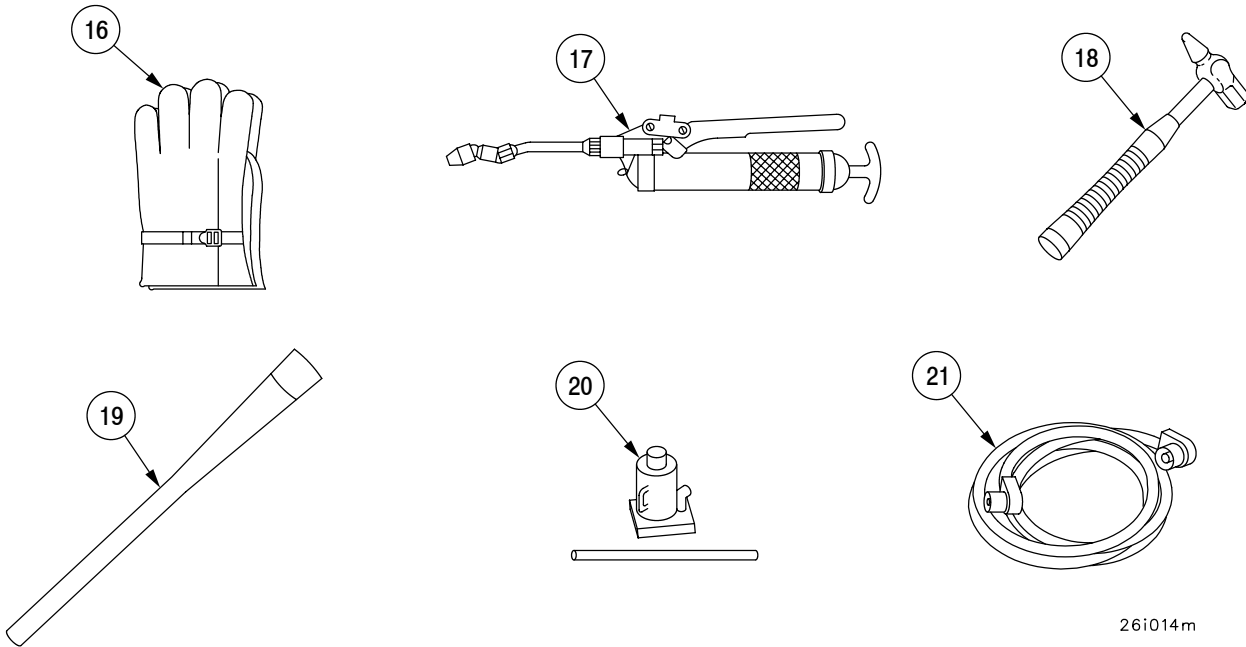

26i014m

(1) Illus Number	(2) National Stock Number	(3) Description CAGEC and Part Number	(4) U/M	(5) QTY REQ
16	8415-00-268-7870	Gloves, Leather, Work w/o Gauntlet (81348), MIL-G-2366	PR	3
17	4930-01-766-3545	Grease Gun, Hand, High Pressure, 21 oz. Cap 18,000 psi (OGF30) 6243-J3	EA	2
18	5120-00-061-8546	Hammer	EA	1
19	5120-00-288-6574	Handle, Mattock, 36" Long, Grade AA (19207) 11677021	EA	1
20	5120-00-188-1790	Jack, Hydraulic, Hand, 30-ton with Operating Handle (99696) 5029209-11-101	EA	1
21	2590-00-148-7961	Kit, Slave Cable, Special Purpose (19207) 11682379-1	EA	1

COMPONENTS OF END ITEM (COEI) AND BASIC ISSUE ITEMS (BII) LISTS - CONTINUED

0133 00

Table 2 BASIC ISSUE ITEMS LIST - CONTINUED

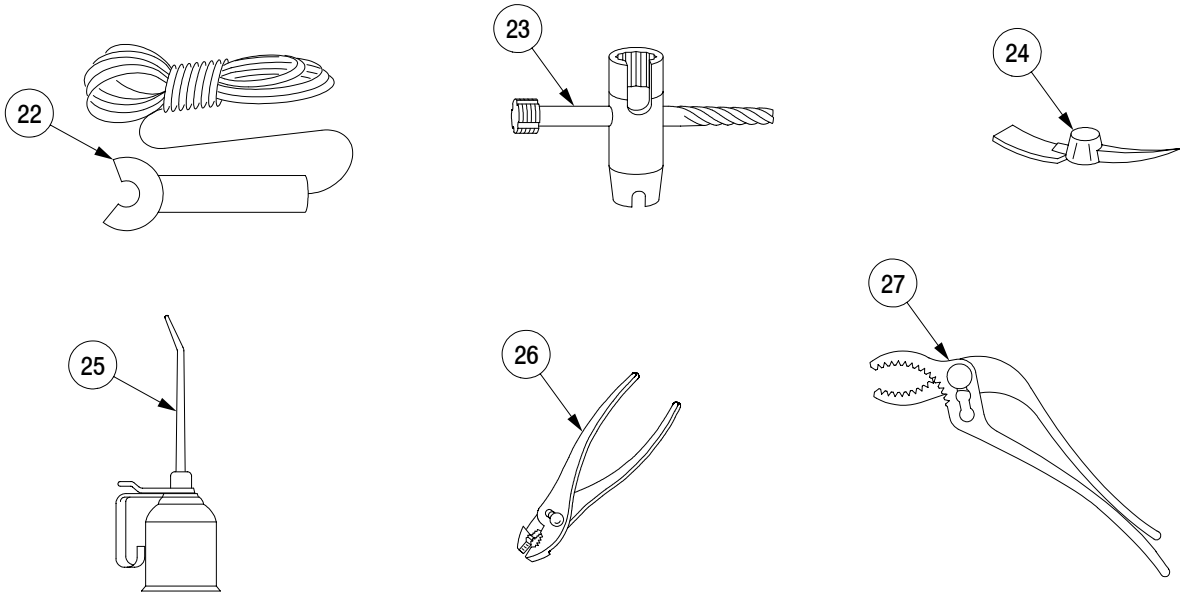

26i015m

(1) Illus Number	(2) National Stock Number	(3) Description CAGEC and Part Number	(4) U/M	(5) QTY REQ
22	6230-00-086-4293	Light, Inspection	EA	2
23	5120-00-246-2311	Lubrication Fitting Tool	EA	1
24	5120-00-243-2395	Mattock, Pick, without Handle (19207) 11677022	EA	1
25	4930-00-262-8868	Oiler, Hand Type I	EA	1
26	5120-00-239-8251	Pliers, 8" (72368) 1950	EA	1
27	5120-00-624-8065	Pliers, Slip Joint w/Removable Plastic Inserts, 9 in. long	EA	1

COMPONENTS OF END ITEM (COEI) AND BASIC ISSUE ITEMS (BII) LISTS - CONTINUED

0133 00

Table 2 BASIC ISSUE ITEMS LIST - CONTINUED

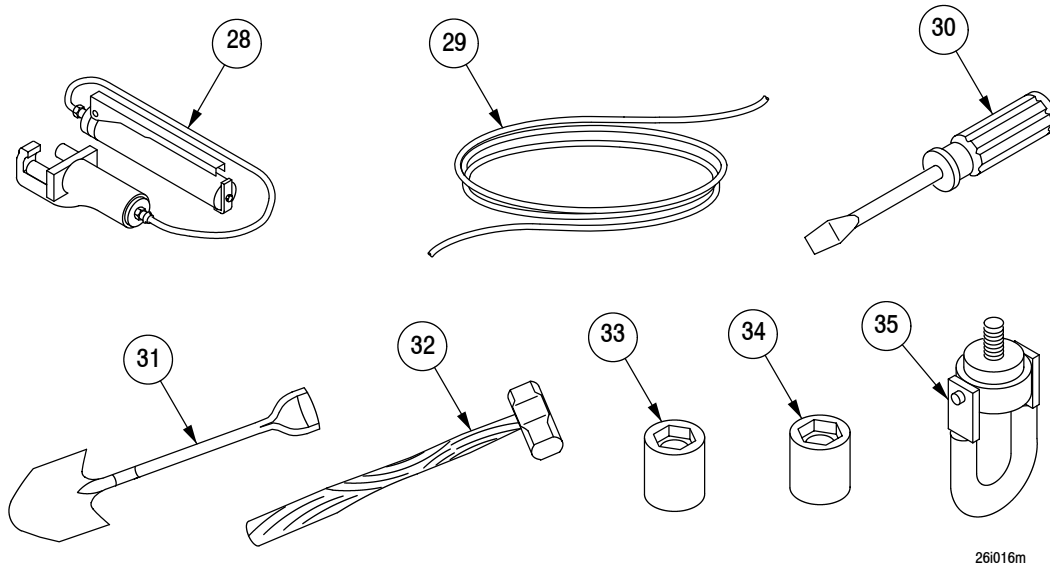

26i016m

(1) Illus Number	(2) National Stock Number	(3) Description CAGEC and Part Number	(4) U/M	(5) QTY REQ
28	5120-01-052-5642	Puller & Pump, Track End Connector (19207) 8708874	EA	1
29	4020-01-204-7039	Rope, Fiberous, 100' (19207) 12322571	EA	1
30	5120-01-335-6542	Screwdriver, Flat Tip (58536) A-A-2712	EA	1
31	5120-00-293-3336	Shovel, General Purpose	EA	1
32	5120-00-900-6097	Sledge, Blacksmith, Double Face, 10 lbs (58536) A-A-1293	EA	1
33	5130-00-964-9113	Socket, Socket Wrench Power Drive, 6-point, Thin Wall, 1-1/4" Opening (19207) 10894847	EA	1
34	5130-01-084-6025	Socket, Socket Wrench, Power Drive, 6-point, Thin Wall, 1-5/16" Opening (used on track center guide nut) (19207) 10894847-1	EA	1
35	TBD	Swivel Hoist Ring (19207) 12477781 (US Army)	EA	1

COMPONENTS OF END ITEM (COEI) AND BASIC ISSUE ITEMS (BII) LISTS - CONTINUED

0133 00

Table 2 BASIC ISSUE ITEMS LIST - CONTINUED

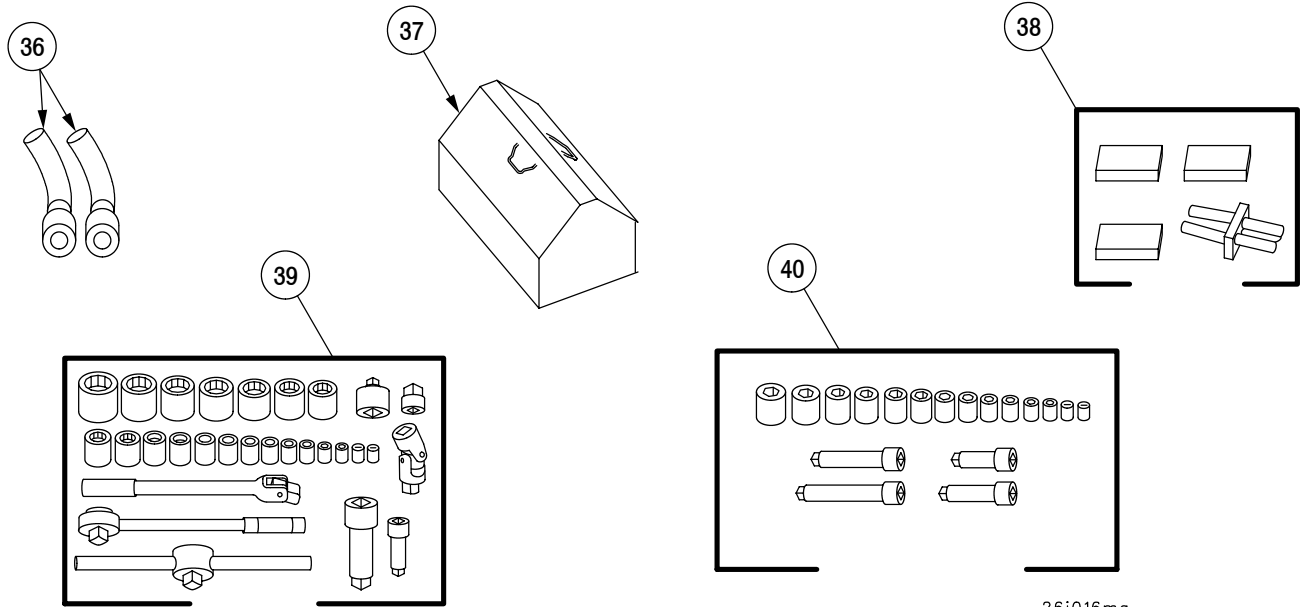

26i016ma

(1) Illus Number	(2) National Stock Number	(3) Description CAGEC and Part Number	(4) U/M	(5) QTY REQ
36	7240-00-177-6154	Spout, Can, Flex Nozzle (19207) 11677020	EA	2
37	5140-00-498-8772	Tool Box, Portable (19207) 07573Y	EA	1
38	9905-00-534-8376	Warning Device Kit, (80822) 1 (Egypt) OR	EA	1
	9905-00-148-9546	Highway Warning Device Set, Portable (19207) 11669000 (Egypt)		
39	5120-00-204-1999	Wrench Set, Socket 3/4" Square Drive, 12-point w/case 7/8" to 2" Opening 21 Pieces (81348) GGG-W-641	EA	1
40	5130-00-357-5135	Wrench Set, Socket 3/4" Square Drive, 6-point, Heavy-Duty, w/case & Extension Bars, 9/16" to 1-1/2" Opening, 16 Pieces (58536) A-A-399A	EA	1

COMPONENTS OF END ITEM (COEI) AND BASIC ISSUE ITEMS (BII) LISTS - CONTINUED

0133 00

Table 2 BASIC ISSUE ITEMS LIST - CONTINUED

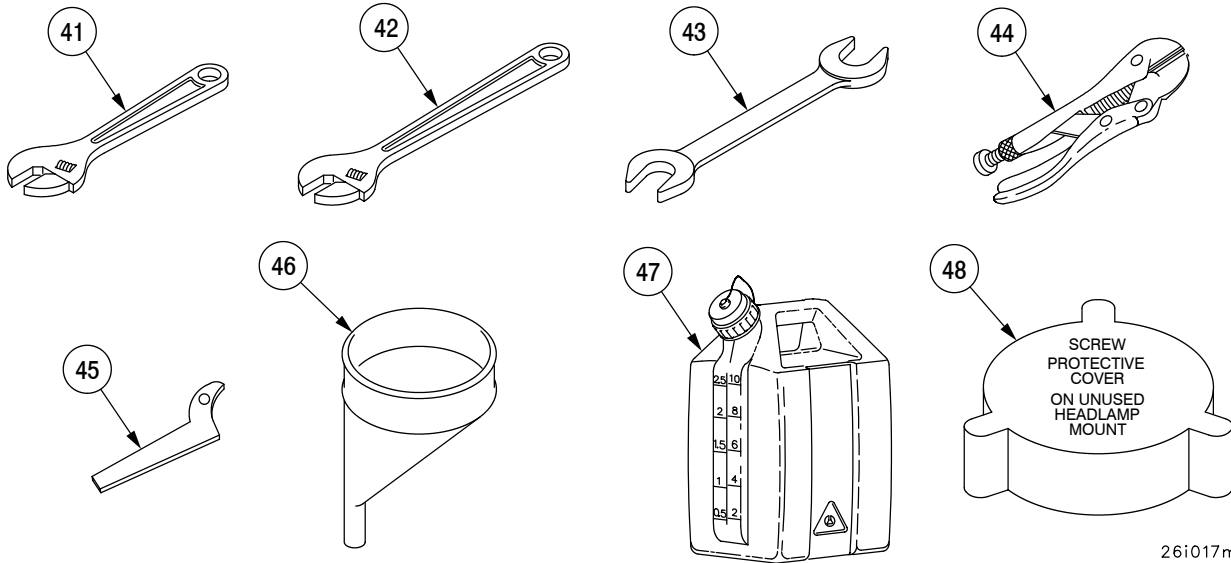

(1) illus Number	(2) National Stock Number	(3) Description CAGEC and Part Number	(4) U/M	(5) QTY REQ
41	5120-00-264-3793	Wrench, Adjustable, 15" Long (24617) 2117080	EA	1
42	5120-00-240-1414	Wrench, Adjustable, 18" Long (11915) 11205	EA	1
43	5120-00-277-2307	Wrench, Open End	EA	1
44	5120-00-277-4244	Wrench, Pliers, 1-3/4" Opening (81348) GGG-W-00649	EA	1
45	5120-00-277-9076	Wrench, Spanner (65814) 1474	EA	1
46		Funnel, Offset (19207) 12477631	EA	1
47	8125-01-502-0900	Utility Jug, Measure and Fill (19207) 12477632	EA	1
48	5340-00-934-8251	Cap, Protective, Dust (US Army)	EA	2

END OF TASK

ADDITIONAL AUTHORIZATION LIST

0134 00

This work package lists additional items authorized for the support of the M88A2 Recovery Vehicle.

GENERAL

This list identifies items that do not have to accompany the M88A2 HRV and that do not have to be turned in with it. These items are all authorized to you by CTA, MTOE, TDA or JTA.

EXPLANATION OF COLUMNS

Column (1) National Stock Number - Indicates the National Stock Number assigned to the item which will be used for requisitioning.

Column (2) Description CAGEC and Part Number, and the Usable On Code - Identifies the Federal item name followed by a minimum description when needed. The last line below the description is the CAGEC (Commercial And Government Entity Code) (in parentheses) and the part number.

Column (3) Unit of Issue (U/I) - This column indicates how the item is issued for the National Stock Number shown in column 1.

Column (4) Qty Recm - This column lists the quantity of each item required for a complete major item.

(1) NATIONAL STOCK NUMBER	(2) DESCRIPTION CAGEC & PART NUMBER	(3) U/I	(4) QTY RECM
3433-01-327-4609	Exothermic Cutting Torch DF0308 type II (09687)	EA	1

END OF TASK

EXPENDABLE AND DURABLE ITEMS LIST

0135 00

This work package lists the expendable and durable items you will need to operate and maintain the M88A2 Recovery Vehicle. This list is for information purposes only, and is not authority to requisition the listed items. These items are authorized by CT 50-970, Expendable/Durable Items (Except Medical, Class V, Repair Parts, and Heraldic items), or CTA 8-100, Army Medical Department Expendable/Durable Items.

EXPLANATION OF COLUMNS IN THE EXPENDABLE AND DURABLE ITEMS LIST

Column (1) Item number - This number is assigned to the entry in the listing and is referenced in narrative instructions to identify the material (e.g., "Use cleaning compound, (item 6, WP 0135 00)").

Column (2) Level - This column identifies the lowest level of maintenance that requires the listed item.

Column (3) National Stock Number - This is the National Stock Number assigned to the item. Use to request or requisition the item.

Column (4) Description - Indicates the Federal item name and, if required, a description to identify the item. The last line for each item indicates the Commercial and Government Entity Code (CAGEC) and Part Number.

Column (5) Unit of Measure (U/M) - Indicates the measure used in performing the actual maintenance function. This measure is expressed by a two-character alphabetical abbreviation (e.g., ea, in, pr). If the unit of measure differs from the unit of issue, requisition the lowest possible unit of issue that will satisfy your requirements.

EXPENDABLE AND DURABLE ITEMS LIST

(1)	(2)	(3)	(4)	(5)
ITEM NUMBER	LEVEL	NATIONAL STOCK NUMBER	DESCRIPTION	U/M
1	C	8040-00-290-4301	ADHESIVE, RUBBER BASE, GENERAL PURPOSE: Type II, A-1226-B	GL
2	C	8040-00-273-8716	ADHESIVE, BONDING: Vulcanized synthetic rubber to steel, class I, MMM-A-121	QT
3	C	8040-00-833-9563	ADHESIVE SEALANT, SILICONE: White, RTV general purpose, Type I, MIL-A-46106A	TB
4	C	8040-00-809-8252	ADHESIVE, BONDING: MIL-A-1154	GL
5	C	6135-00-090-5365	BATTERY, NON-RECHARGEABLE (Lithium) (80058) BA-5567/U	EA
6	C	6850-00-224-6668	CLEANING COMPOUND, RIFLE MIL-C-372	GT
7	C	5350-00-221-0872	CLOTH, ABRASIVE CROCUS (81348) P-C-458	PG
8	C	8030-00-231-2345	CORROSION PREVENTIVE COMPOUND: GR1, MIL-C-16173	GL
9	C	8030-00-062-5866	CORROSION PREVENTIVE COMPOUND: GR4, MIL-C-16173	GL
10	C	7930-00-068-1669	DETERGENT, GENERAL PURPOSE P-D-1747	CO
11	C	6850-00-281-1985	DRY-CLEANING SOLVENT: P-D-680	PT
12	C	8010-00-111-7930	ENAMEL, ALKYD, CAMOUFLAGE: Forest green, MIL-E-52798A	QT

EXPENDABLE AND DURABLE ITEMS LIST - CONTINUED

0135 00

(1)	(2)	(3)	(4)	(5)
ITEM NUMBER	LEVEL	NATIONAL STOCK NUMBER	DESCRIPTION	U/M
13	C	8010-00-052-8818	ENAMEL, ALKYD, SEMIGLOSS: Red, TT-E-529D	PT
14	C	8010-00-052-8818	ENAMEL, ALKYD, SEMIGLOSS: White, TT-E-529D	PT
15	C	8010-00-298-2288	ENAMEL, SYNTHETIC, GLOSS: White, class A, TT-E-489G	GL
16	C	9150-00-190-0905	GREASE, AUTOMOTIVE AND ARTILLERY: MIL-G-10924C	LB
17		9150-01-158-0462	HYDRAULIC FLUID, FIRE RETARDANT MIL-H-46170	DR
18	C	5970-00-644-2636	INSULATION, TAPE, ELECTRICAL: Black, pressure sensitive adhesive, plastic, 0.0085 thk by .075 wide, HH-I-595C	RL
19	C	8010-00-161-5722	LACQUER, CLEAR: Spray, TT-L-581	CN
20	C	9150-00-231-6689	LUBRICATING OIL: General purpose, preservative (water displacing, low temperature), VV-L-800A	GL
21	C	9150-01-035-5390	LUBRICATING OIL: Gear, multi-purpose, grade 90, MIL-L-2105C	GL
22	C	9150-00-111-0201	LUBRICATING OIL: Internal combustion engine, preservative and break-in, Type I, grade 10, MIL-L-21260C	GL
23	C	9150-00-111-0201	LUBRICATING OIL: Internal combustion engine, preservative and break-in, Type I, grade 30, MIL-L-21260C	GL
24	C		LUBRICATING OIL: Contract and volatile corrosion inhibited, MIL-R-46002A	GL
25	C	9150-01-433-7974 9150-01-433-7986 9150-01-433-7978 9150-01-422-9346 9150-01-438-6082 9150-01-438-6079	LUBRICATING OIL: ENGINE, (OE), MIL-2104 (81349) 1 QT Can, OE30 5 GL Can, OE30 55 GL Drum, OE30 1 QT Can, 15W40 5 GL Can, 15W40 55 GL Drum, 15W40	QT CN DR QT CN DR
26	C	9150-00-186-6668	LUBRICATING OIL: Spec MIL-L-2104, Gr 10 for 0°F to 30°F	GL
27	C		LUBRICATING OIL: Spec MIL-L-46167, Engine Arctic	GL
28	C	9150-00-889-3532	LUBRICATING OIL: MIL-L-46000	GL

EXPENDABLE AND DURABLE ITEMS LIST - CONTINUED

0135 00

(1)	(2)	(3)	(4)	(5)
ITEM NUMBER	LEVEL	NATIONAL STOCK NUMBER	DESCRIPTION	U/M
29	C	----- 9150-01-424-7696 9150-01-424-7692 9150-01-424-7698	LUBRICATING OIL: Grade 10, CAT-TDIO, TO-4 1 QTCan 5 GL Can 55 GL Drum	QT CN DR
30	C		WIRE ROPE, Exposed Gear, W-L-751	GL
31	C	8010-00-111-8069	PAINT, CAMOUFLAGE: Desert sand, MIL-E-52798, FED-STD-575A, color number 23448L	GL
32	C	8010-00-111-8069	PAINT, STENCIL: Lusterless white, MIL-E-52798, FED-STD-595, color number 37875	PT
33	C	8010-00-111-8069	PAINT, STENCIL: Lusterless white, MIL-E-52798, FED-STD-595, color number 37875	PT
34	C	8010-00-111-8069	PAINT, STENCIL: Lusterless black, MIL-E-52798, FED-STD-595, color number 37038	PT
35	C	6640-00-240-5851	PAPER, LENS TISSUE: Type I, 4- by 6-inch sheets, UU-P-313	EA
36	C	8010-00-292-3048	PRIMER, SURFACER, SANDING, LACQUER AND ENAMEL TYPE: Surf white, TT-P-659C	GL
37	C	8030-00-159-8177	SEALER, Spec MIL-S-12158	PT
38	C	6850-00-177-5094	SILICONE COMPOUND: MIL-S-86608	LB
39	C	3439-00-006-7764	SOLDER, TIN ALLOY, LEAD ALLOY: SN 60/40, form B, Type S, QQ-S-571E	LB
40	C		TAPE, TEFLON, THREAD SEALANT: 1/2-inch wide, Dwg 10379740	RL
41	C	8010-00-160-5794	THINNER: Synthetic resin enamels, TT-T-306C	GL
42	C	8010-00-242-2089	THINNER: Paint, mineral spirits, odorless, volatile, TT-T-291	GL
43	C	8010-00-165-4432	VARNISH: Spec TT-V-121	PT
44	C	5610-00-141-7838	WALKWAY COMPOUND, NONSLIP: Forest green, MIL-W-5044C	GL
45	C	7920-00-205-1711	WIPING RAGS: Cotton material unbleached	BE
46	C	9150-00-889-3532	LUBRICATING OIL MIL-L-46000	BT

EXPENDABLE AND DURABLE ITEMS LIST - CONTINUED

0135 00

(1) ITEM NUMBER	(2) LEVEL	(3) NATIONAL STOCK NUMBER	(4) DESCRIPTION	(5) U/M
47	C	5510-00-220-6080	LUMBER: 1-inch thick, 6-inch wide MM-L-751	BF

END OF TASK

STOWAGE AND SIGN GUIDE

0136 00**THIS WORK PACKAGE COVERS:**

General, Stencil Locations (Hull Exterior), Stencil and Label Locations (Hull Interior), Stowed Items Location Index (Exterior), Stowed Items Location Index (Interior)

INITIAL SETUP:**References**

WP 0133 00

WP 0134 00

This work package shows the locations for stowage of equipment and materiel required to be carried on the M88A2 Recovery Vehicle.

GENERAL

The following illustrations show the location of stencils, both interior and exterior, used on the M88A2. The signs mark the place where equipment should be stowed. In addition to the location of signs, these guides detail the physical installation and stowage of all Components of End Item (COEI) (WP 0133 00, Table 1), Basic Issue Items (BII) (WP 0133 00, Table 2), and Additional Authorization List (AAL) (WP 0134 00) items required to be carried on-board the vehicle.

Table 1 STENCIL LOCATIONS (HULL EXTERIOR)

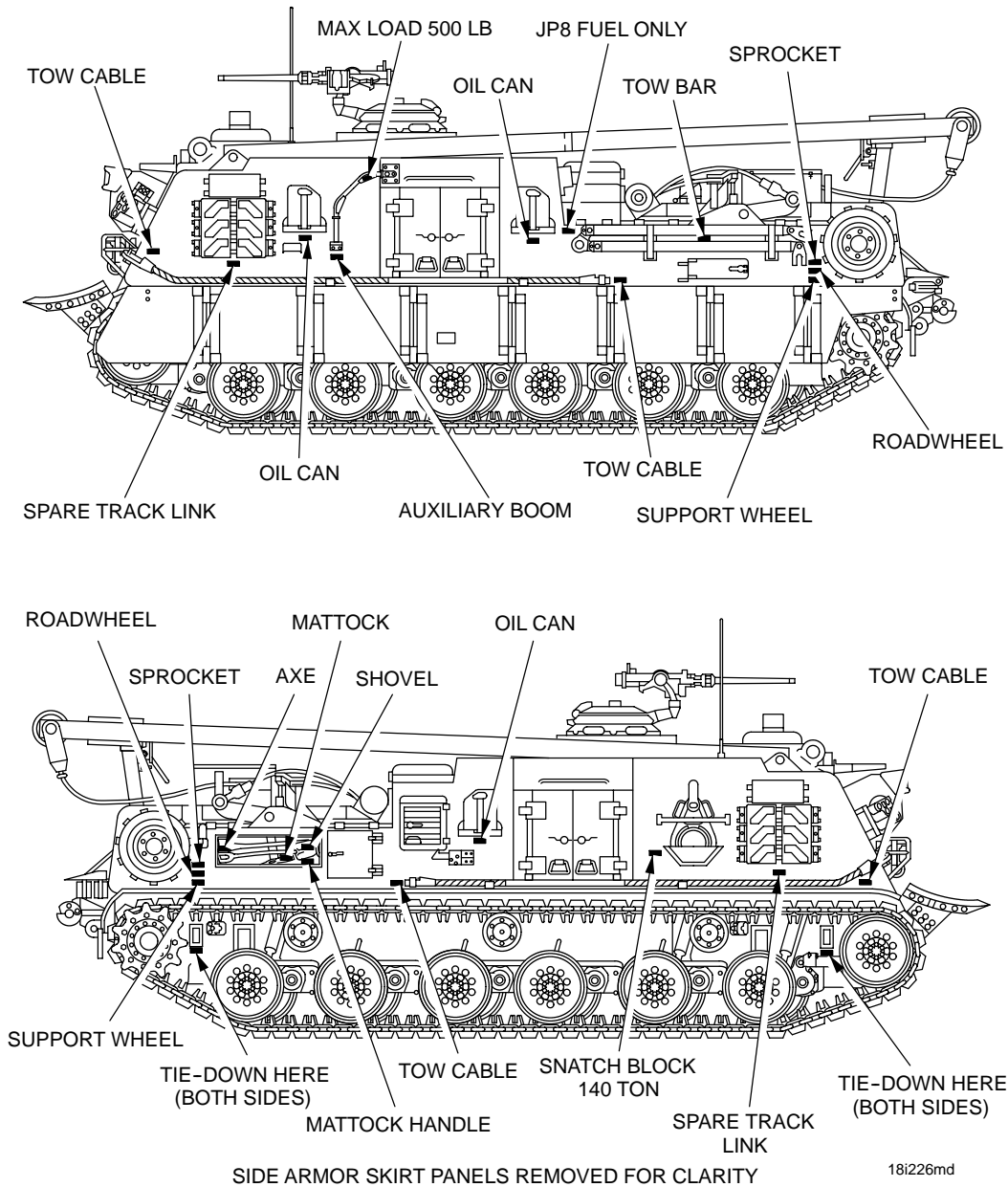

Table 1 STENCIL LOCATIONS (HULL EXTERIOR) - CONTINUED

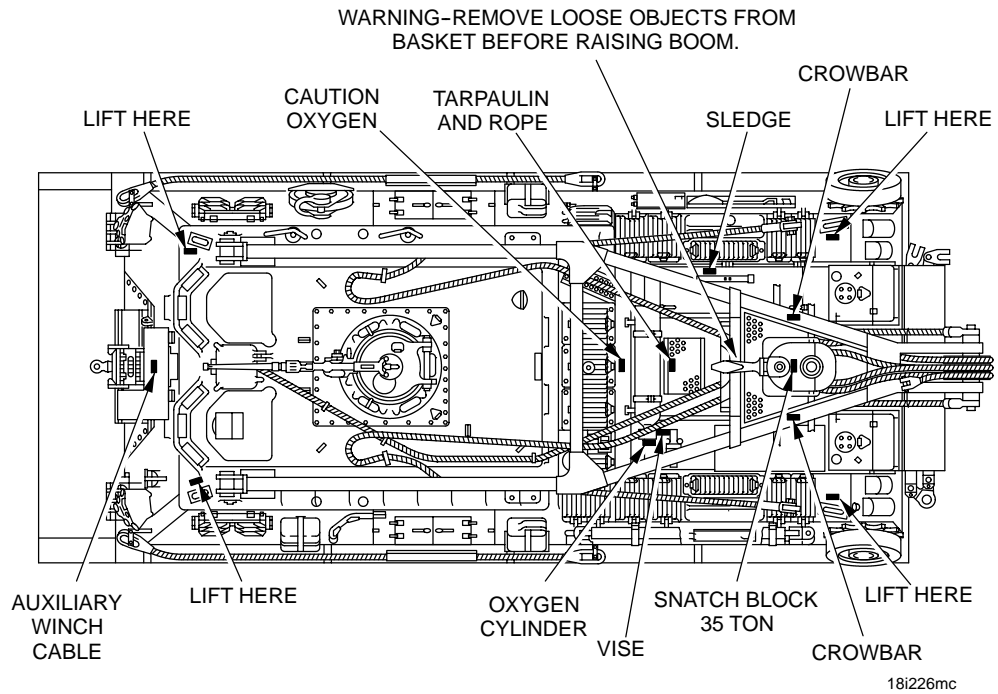
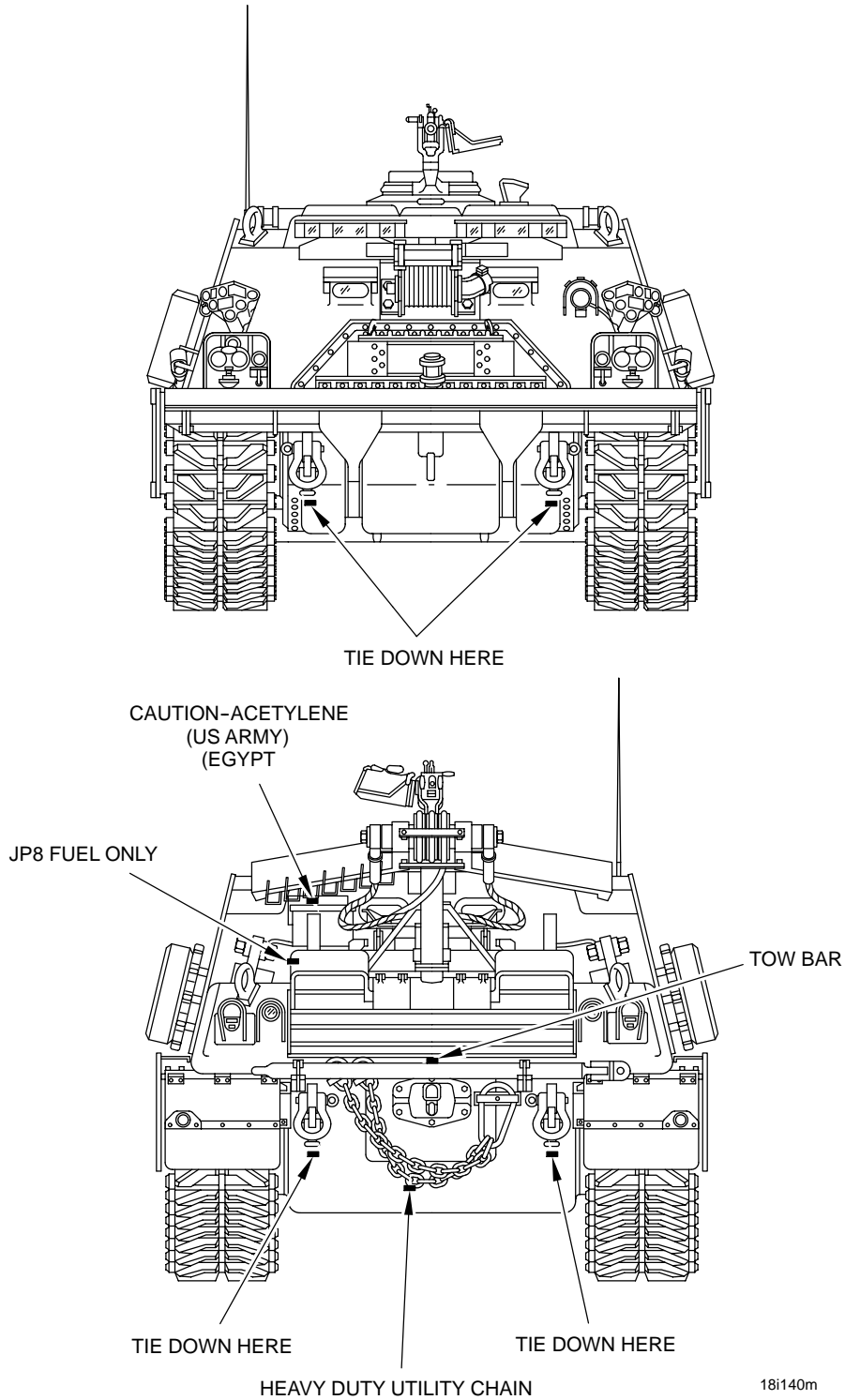
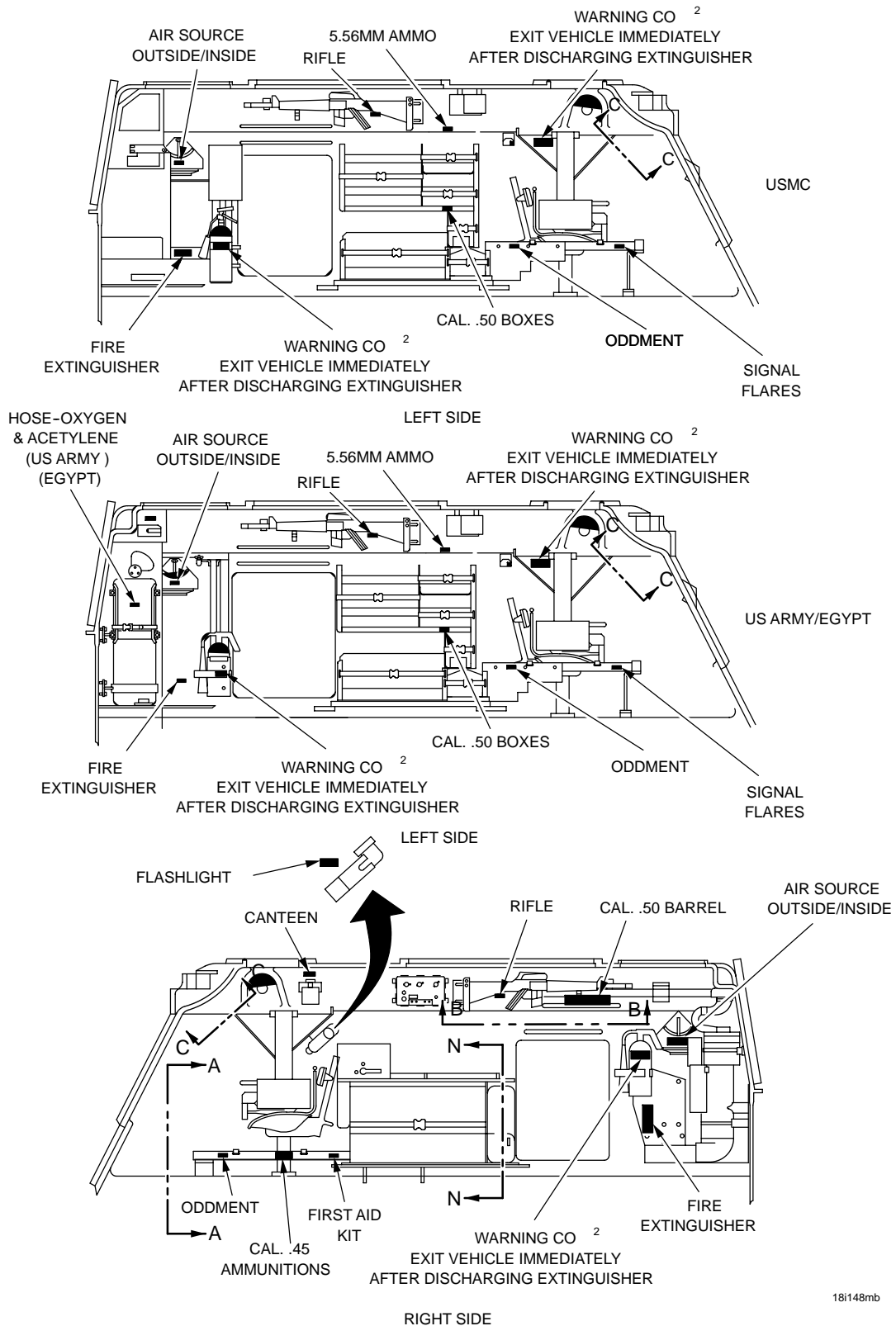

Table 1 STENCIL LOCATIONS (HULL EXTERIOR) - CONTINUED



18i140m

Table 2 STENCIL AND LABEL LOCATIONS (HULL INTERIOR)



18i148mb

Table 2 STENCIL AND LABEL LOCATIONS (HULL INTERIOR) - CONTINUED

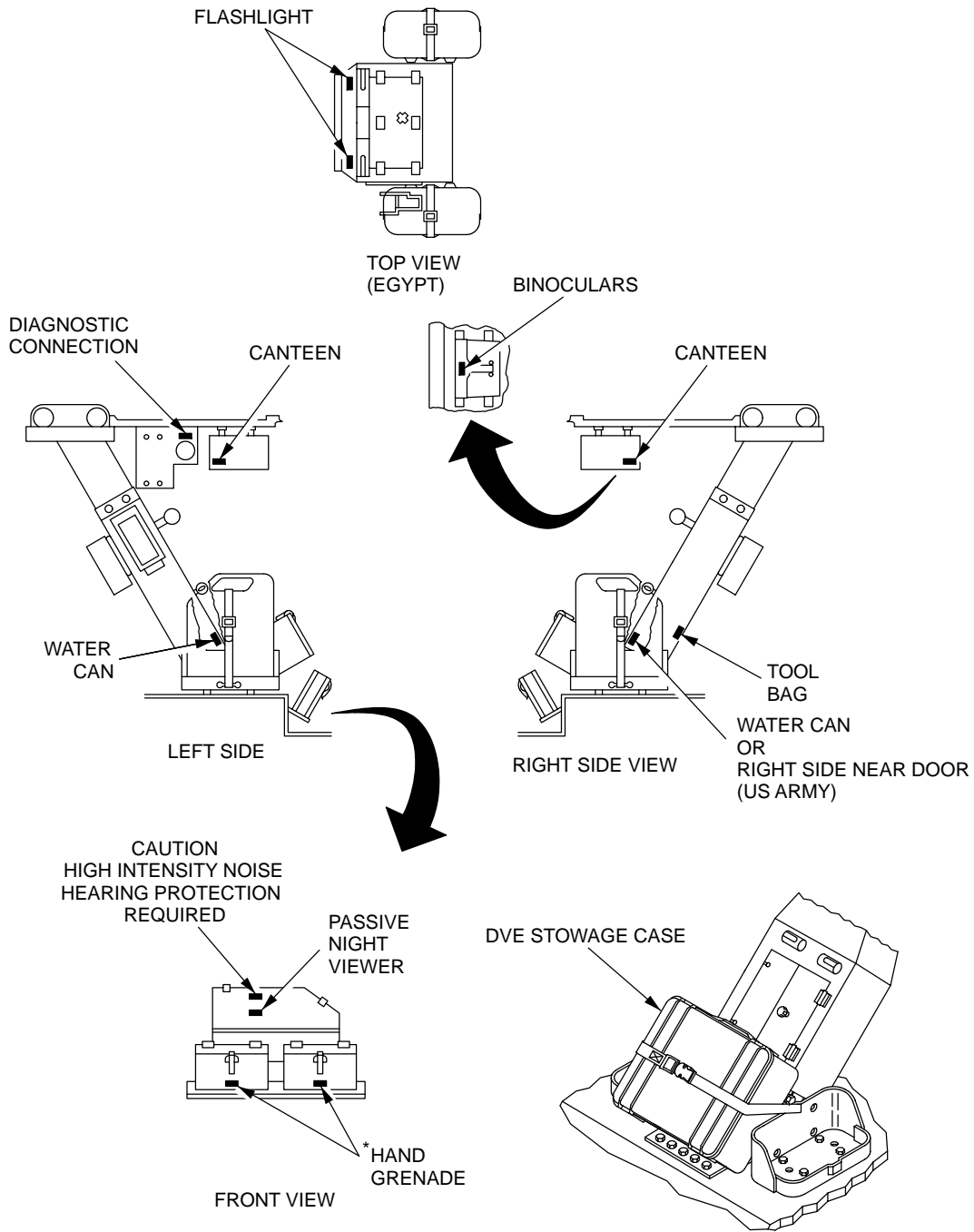

* NOTE: SOME VEHICLES ARE NOT EQUIPPED WITH HAND GRENADE BOXES

181056m

Table 2 STENCIL AND LABEL LOCATIONS (HULL INTERIOR) - CONTINUED

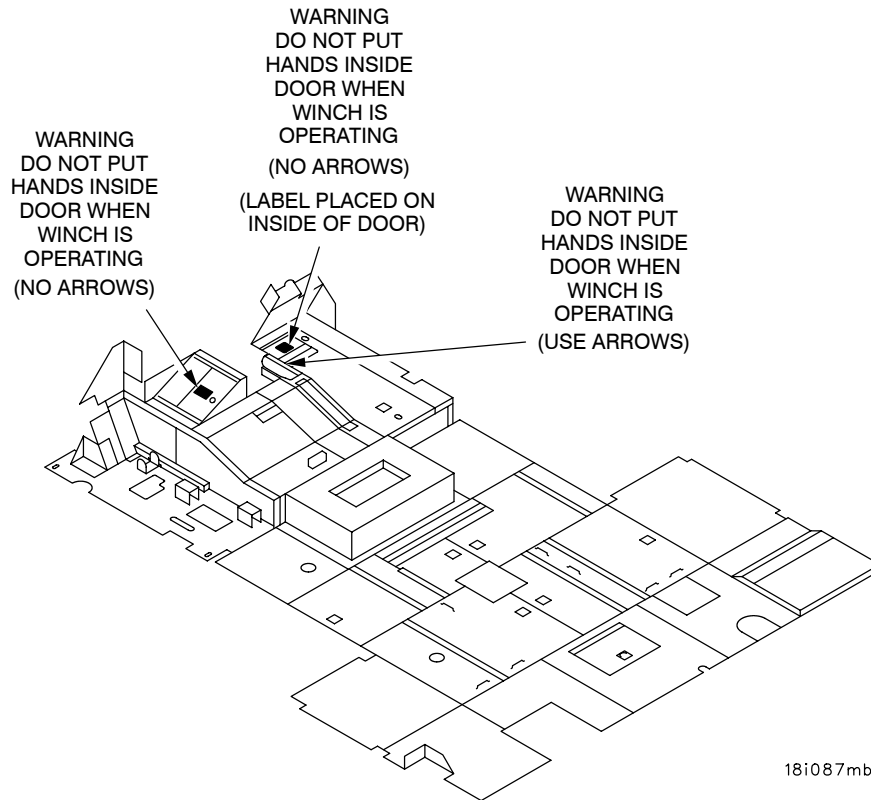
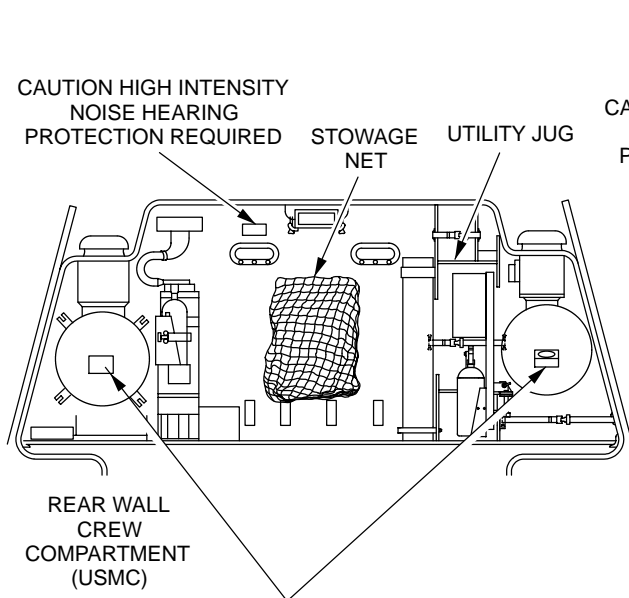
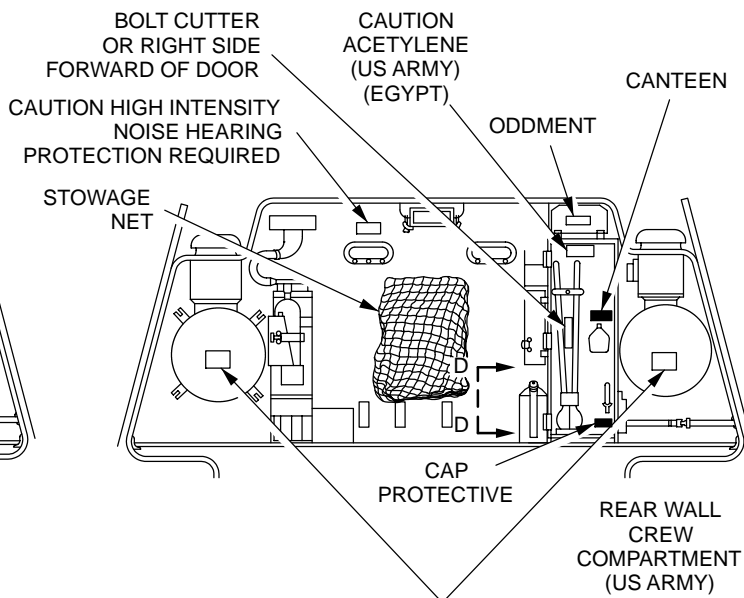

Table 2 STENCIL AND LABEL LOCATIONS (HULL INTERIOR) - CONTINUED



WARNING

IF NBC EXPOSURE IS SUSPECTED, ALL AIR FILTER MEDIA WILL BE HANDLED BY PERSONNEL WEARING FULL NBC PROTECTIVE EQUIPMENT. SEE OPERATOR/MAINTENANCE MANUALS.



WARNING

IF NBC EXPOSURE IS SUSPECTED, ALL AIR FILTER MEDIA WILL BE HANDLED BY PERSONNEL WEARING FULL NBC PROTECTIVE EQUIPMENT. SEE OPERATOR/MAINTENANCE MANUALS.

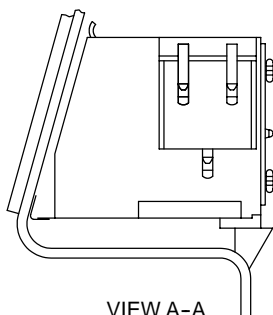

VIEW A-A

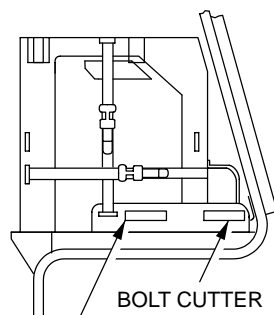

VIEW N-N
BOLT CUTTER
WATER CAN

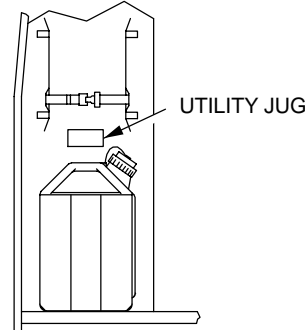

VIEW D-D
UTILITY JUG

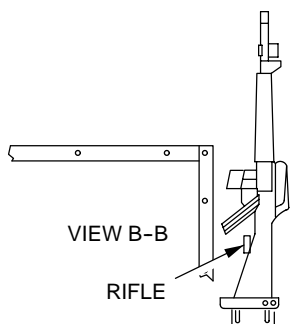

VIEW B-B
RIFLE

* CAUTION HIGH INTENSITY NOISE HEARING PROTECTION REQUIRED

CAUTION BEFORE OPERATING VEHICLE FUEL CONTROL VALVE FORWARD TANK MUST BE CLOSED

CAUTION TURN OFF ALL COMMUNICATION EQUIPMENT BEFORE STARTING OR STOPPING ENGINE

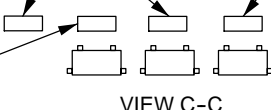

VIEW C-C

* NOTE: FOUR ARE REQUIRED IF VEHICLE IS EQUIPPED WITH DVE

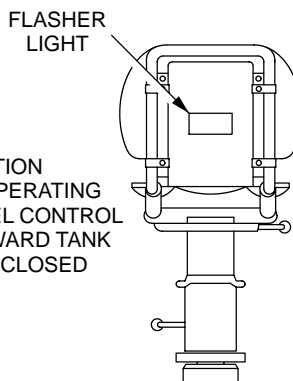

REAR VIEW COMMANDER'S SEAT
FLASHER LIGHT

18i084ma

Table 3 STOWED ITEMS LOCATION INDEX (EXTERIOR)

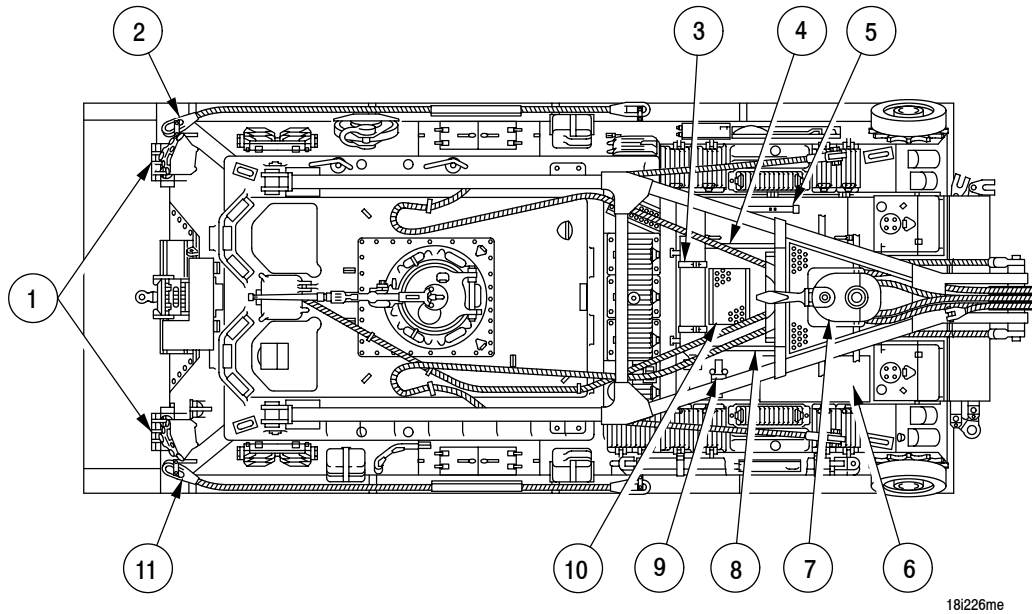

18i226me

- | | |
|--|--|
| <ul style="list-style-type: none"> 1. Spare Lamp Incandescent 2. Towing Cable 3. Oxygen Cylinder 4. Crow Bar 5. Sledgehammer 6. <ul style="list-style-type: none"> a. Chain Hoist b. 6.5-ton Snatch Block c. Track Connect Fixture (2) d. Shackle, High Strength, 2" dia. (COEI #42) e. Shackle, 18 ton (COEI #40) | <ul style="list-style-type: none"> 7. 35-ton Hook Block 8. Crow Bar 9. Vise 10. <ul style="list-style-type: none"> a. Cotton Duck Paulin b. Rope, 100 ft. 11. Towing Cable |
|--|--|

Table 3 STOWED ITEMS LOCATION INDEX (EXTERIOR) - CONTINUED

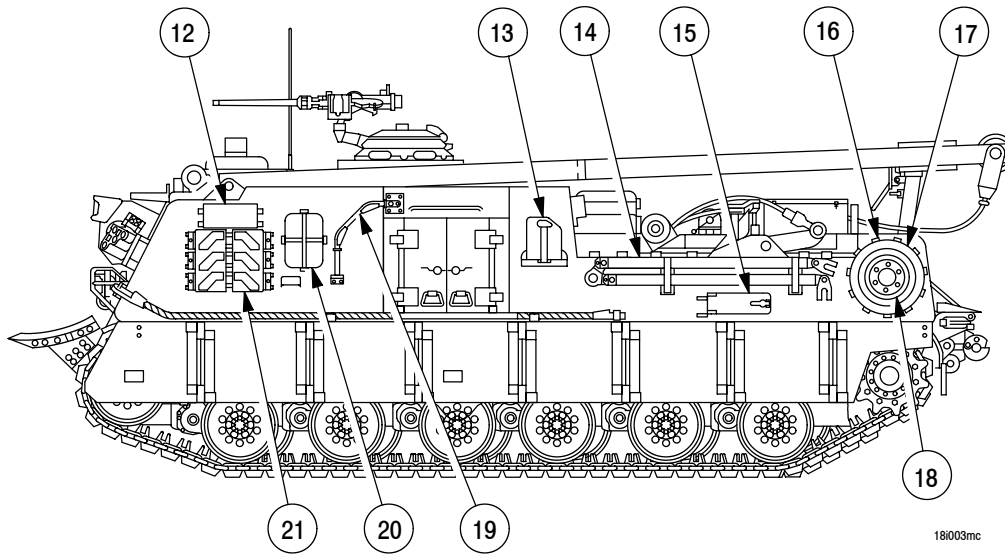

181003mc

- | | |
|--|---|
| <ul style="list-style-type: none"> 12. Smoke Grenades 13. Oil Can 14. Tow Bar and M1 Clevis 15. <ul style="list-style-type: none"> a. Slave Cable Kit b. Center Guide Assembly (6 ea) c. End Connector Assembly (6 ea) d. Hose, Hydraulic, Impact Wrench (2 ea) 16. Sprocket | <ul style="list-style-type: none"> 17. Roadwheel 18. Support Wheel 19. Auxiliary Boom 20. Decontaminating Kit or Oil Can 21. Spare Track Shoes |
|--|---|

Table 3 STOWED ITEMS LOCATION INDEX (EXTERIOR) - CONTINUED

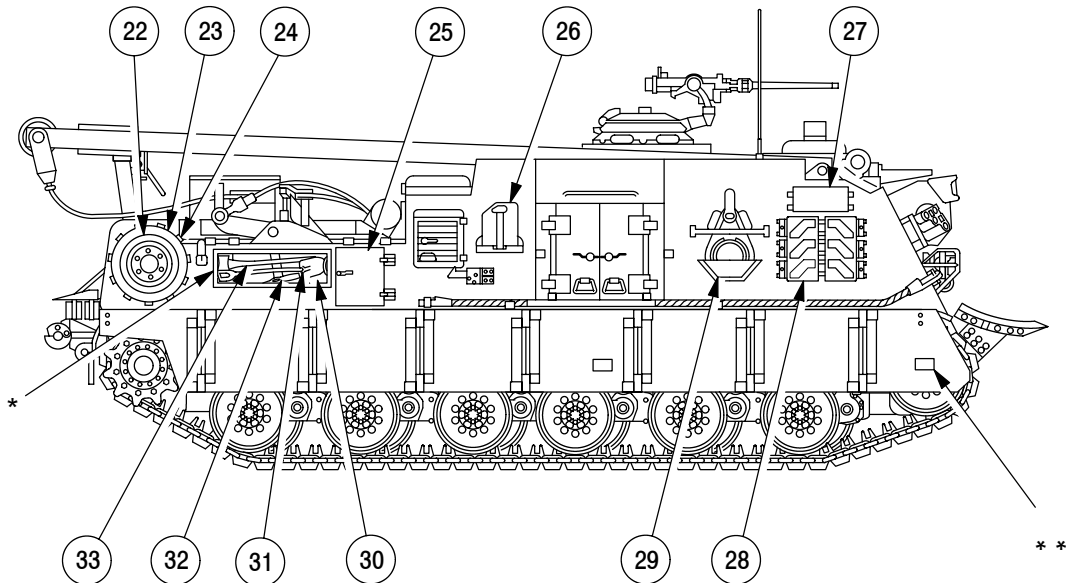

* SOME VEHICLES MAY BE EQUIPPED WITH AN ENCLOSED PIONEER TOOL KIT

** SOME VEHICLES MAY BE EQUIPPED WITH A STEP ON FRONT ARMOR SKIRT

18i074ma

- | | |
|--------------------------------------|--------------------------|
| 22. Support Wheel | 26. Oil Can |
| 23. Roadwheel | 27. Smoke Grenades |
| 24. Sprocket | 28. Spare Track Shoes |
| 25. a. Nozzle and Fuel Hose Assembly | 29. 140-ton Snatch Block |
| b. Nozzle Filler Tube | 30. Mattock Handle |
| c. Funnel | 31. Shovel |
| d. Hydraulic Impact Hoses | 32. Mattock Head |
| e. Hydraulic Impact Wrench | 33. Axe |
| f. Funnel Offset | |

Table 3 STOWED ITEMS LOCATION INDEX (EXTERIOR) - CONTINUED

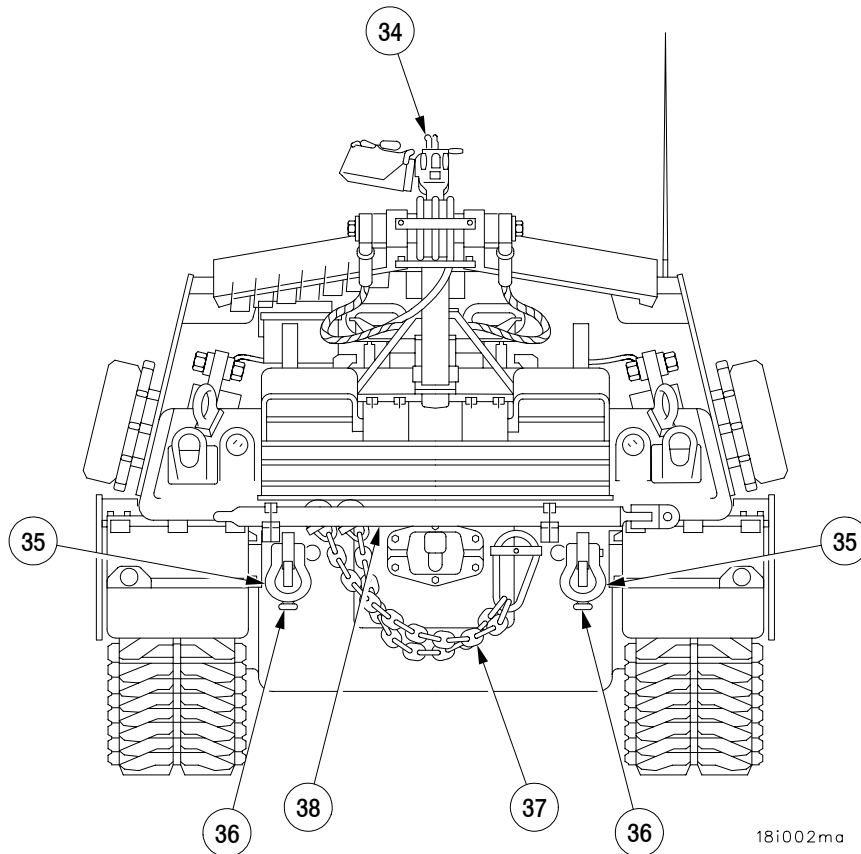

18i002ma

- 34. Machinegun, .50 Caliber and Mount
- 35. Shackle, 50 Ton (Front and Rear)
- 36. Tow Hook (Front and Rear)
- 37. Chain, Lifting, Heavy Duty
- 38. Tow Bar and M1 Clevis

Table 4 STOWED ITEMS LOCATION INDEX (INTERIOR)

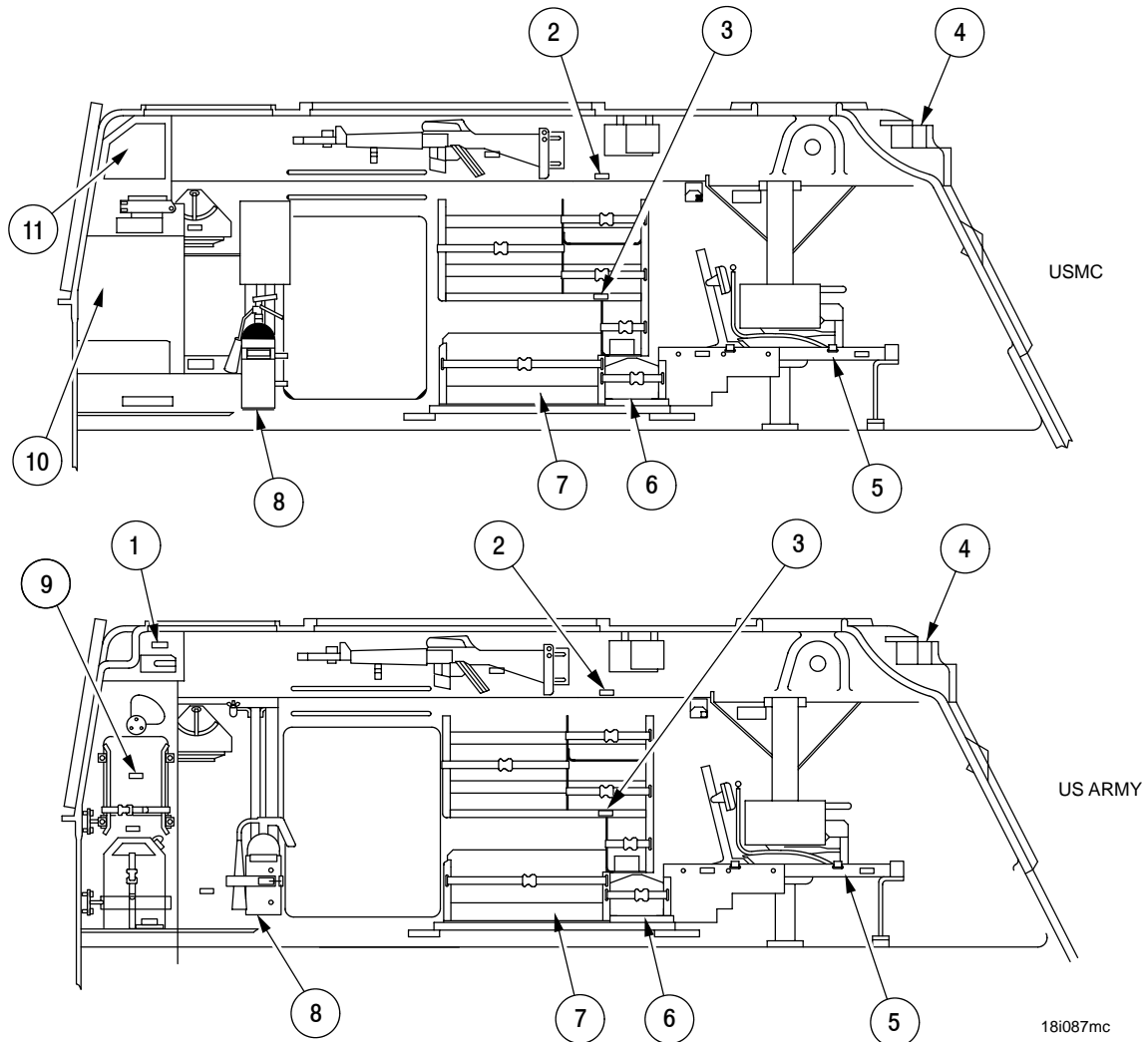

- | | |
|---|---|
| <ol style="list-style-type: none"> 1. Flashlight 2. Ammo Box 5.56 cal (2 boxes) 3. Ammo Box .50 cal (13 boxes) 4. Periscope, M17 (3 ea) 5. Wrench Set, Impact 6-pt 6. General Mechanic's Tool Kit 7. <ol style="list-style-type: none"> a. Tool Box b. Adapter, Track Fixture c. Pin, Locking d. Screwdriver e. Wrench, Adjustable, 15" f. Wrench, Adjustable, 18" g. Bolt, Support Roller h. Nut, Sprocket Bolt i. Nut, Roadwheel j. Lubrication Fittings k. Grease Gun l. Pliers, 8" m. Wrench, Pliers, 1-3/4" n. Sling, 4' | <ol style="list-style-type: none"> o. Socket, 6-pt, 1-1/4" p. Socket, 6-pt, 1-5/16" q. Spouts, Can, Flex r. Torch Set s. Spanner Wrench t. Wrench, Torch & Regulator u. Igniter Flint Tip Box v. Goggles w. Igniter x. Asbestos Mittens y. Leather Welding Gloves z. Welding Tips Cleaner Set aa. Pliers, Slipjoint ab. Swivel Hoisting 8. Fire Extinguisher, Portable 9. Welding Hoses 10. Exothermic Cutter 11. Utility Jug |
|---|---|

18i087mc

Table 4 STOWED ITEMS LOCATION INDEX (INTERIOR) - CONTINUED

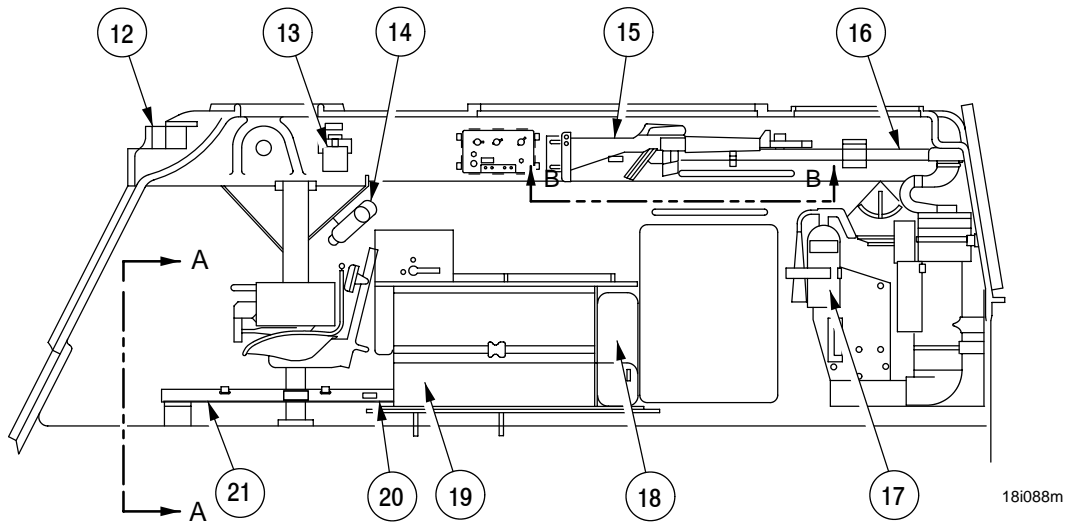

18i088m

- | | |
|--|--|
| <ul style="list-style-type: none"> 12. Periscope M17 (3 ea) 13. Canteen 14. Flashlight 15. Rifle, M16 16. Cal .50 Machinegun Barrel 17. Fire Extinguisher, Portable 18. <ul style="list-style-type: none"> a. Warning Device Kit b. Track End Connector Puller | <ul style="list-style-type: none"> 19. <ul style="list-style-type: none"> a. Lockout Blocks b. Gloves, Leather Work c. Surveying Level d. Grease Gun e. Oiler, Hand Type 20. First Aid Kit 21. Wrench Set, 12 point |
|--|--|

Table 4 STOWED ITEMS LOCATION INDEX (INTERIOR) - CONTINUED

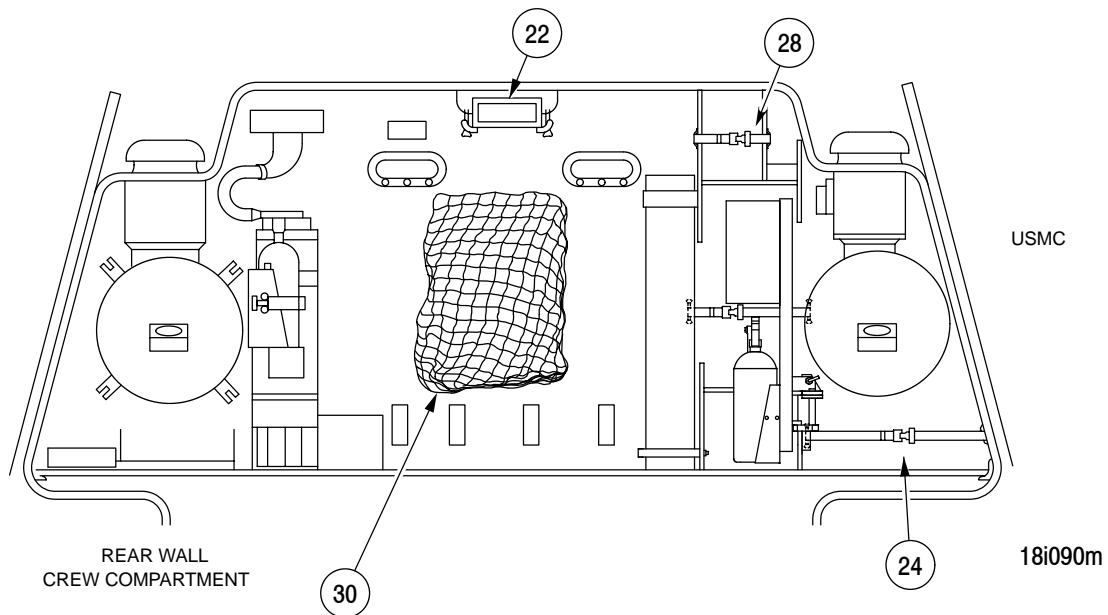
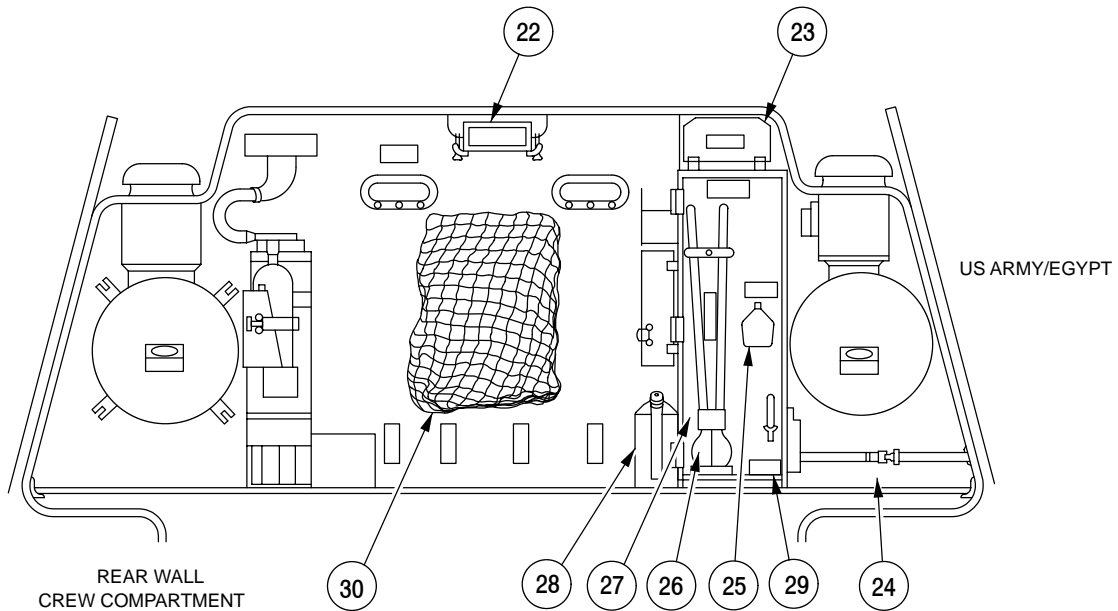

- 22. Periscope, M17
- 23. a. Oxygen Pressure Regulator
b. Acetylene Pressure Regulator (US Army and Egypt)
- 24. Food Rations
- 25. Canteen
- 26. Bolt Cutters or right side forward of door
- 27. Acetylene Cylinder (Inside Compartment) (US Army and Egypt)
- 28. Utility Jug or next to left side air cleaner
- 29. Headlight (Inside Compartment) or small parts drawer, right side
- 30. Cargo Net

Table 4 STOWED ITEMS LOCATION INDEX (INTERIOR) - CONTINUED

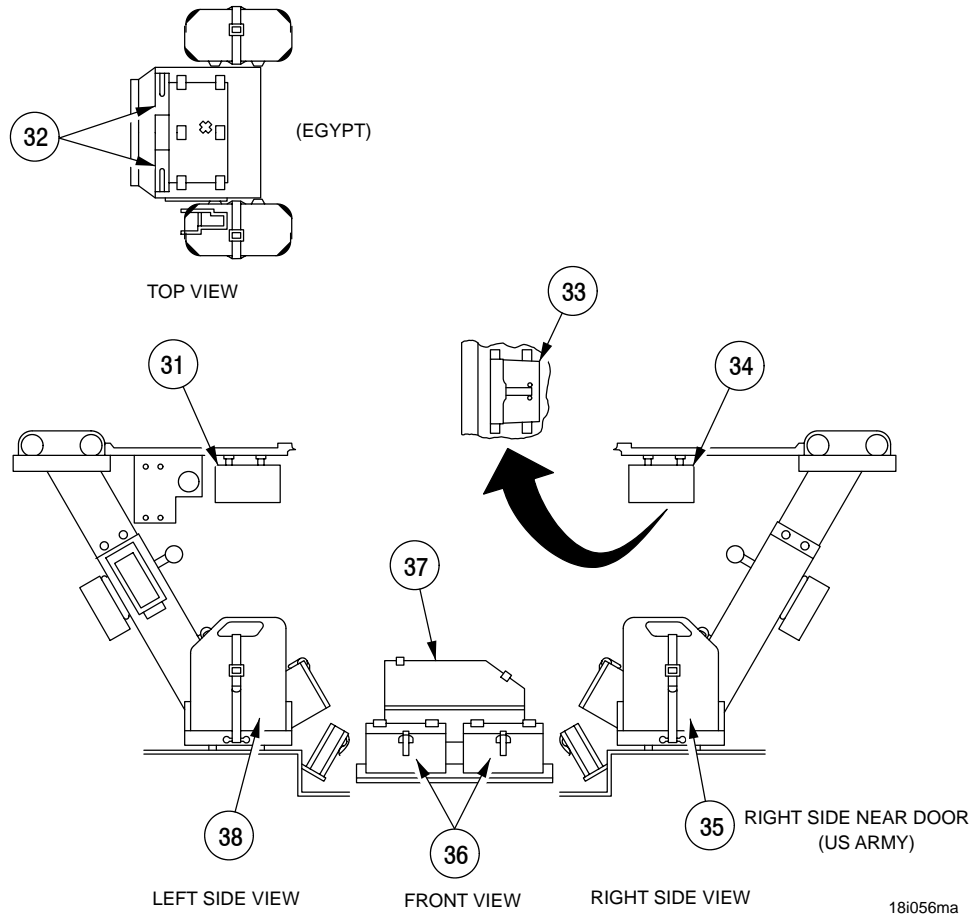

- 31. Canteen
- 32. Flashlights
- 33. Binoculars
- 34. Canteen
- 35. Water Can or right side of crew compartment near door (US Army)
- 36. Hand Grenades
- 37. Passive Night Vision Viewer
- 38. Water Can

18i056ma

Table 4 STOWED ITEMS LOCATION INDEX (INTERIOR) - CONTINUED

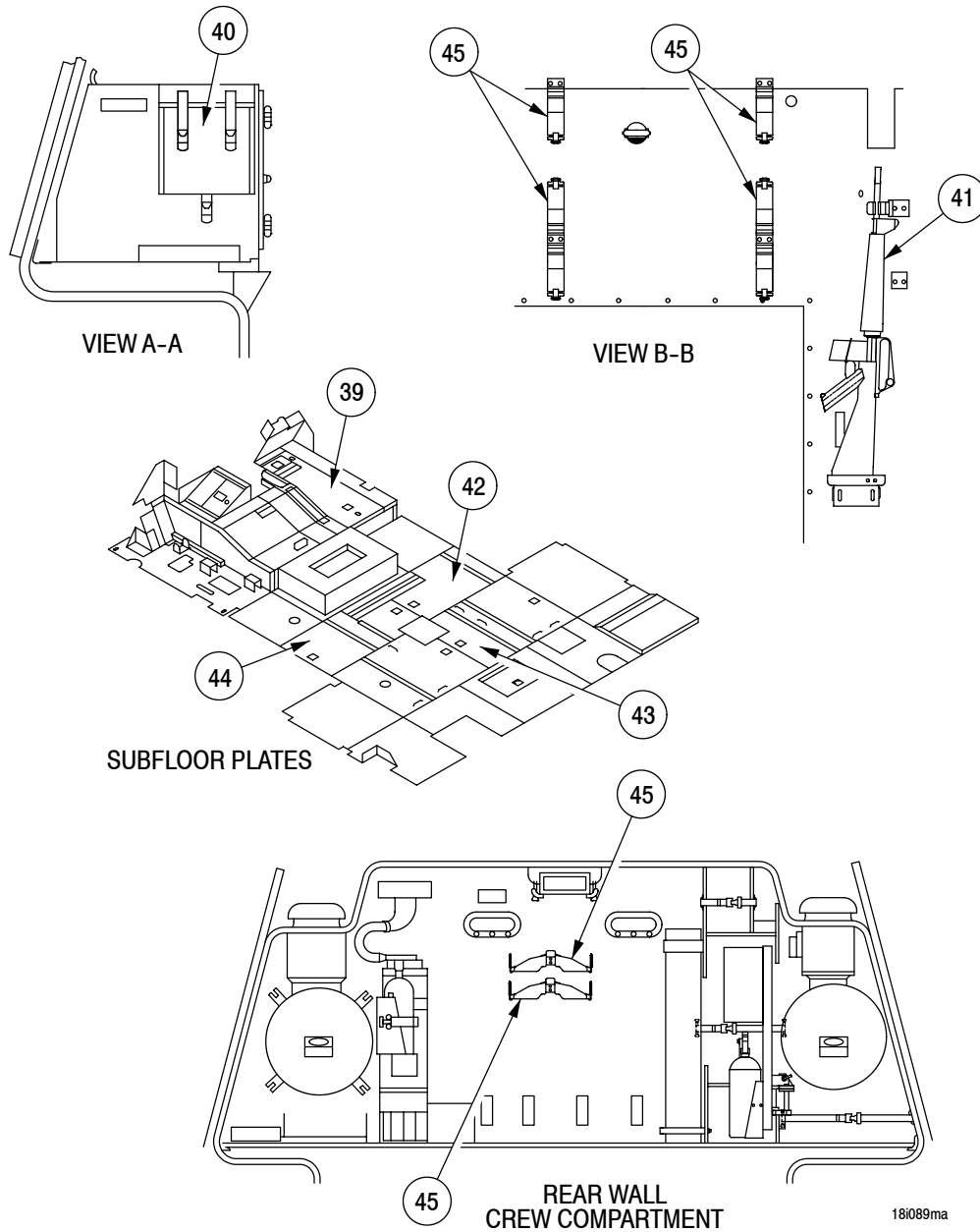

- | | |
|---|--|
| <p>39. Personnel Seats (2)</p> <p>40. a. Bag, Pamphlet
b. Folder, Equipment Record
c. Deleted
d. TM 9-5130-338-12&P</p> <p>41. Rifle, M16</p> | <p>42. Chains, 5/8"x16', Single Leg w/
Hook and End Link (2)</p> <p>43. Shackles, 12.5-ton (COEI #39) (6)</p> <p>44. a. Binder, Track</p> <p>45. AT4</p> |
|---|--|

END OF TASK

ALPHABETICAL INDEX

A

Adjust Operator's and Mechanic's Seat, 0037 00-1
 Adjusting Commander's Seat, 0038 00-1
 Air Cleaner Maintenance, 0116 00-1
 Air Intake System, 0005 00-3
 Air Purification System, 0005 00-12
 Assembly and Preparation for Use, 0010 00-1
 Auxiliary Boom Operation, 0039 00-1
 Auxiliary Equipment Operation, 0053 00-1
 Auxiliary Power Unit, 0005 00-10, 0005 00-11
 Auxiliary Power Unit Air Cleaner, 0117 00-1
 Auxiliary Winch Operation, 0049 00-1

B

Backing the Vehicle, 0018 00-1
 Biological Decontamination, 0084 00-1
 Boom Operation, 0047 00-1

C

Caliber .50 Machine Gun and Mount, 0127 00-1
 Caliber .50 Machine Gun Mount Operation, 0069 00-1
 Commander's Controls and Indicators, 0008 00-1
 Commander's Cupola, 0025 00-1
 Commander's Seat Adjustment, 0038 00-1
 Communications System, 0130 00-1
 Communications System Operation, 0070 00-1
 Cooling System, 0005 00-2
 Corrosion Prevention and Control, 0001 00-1

D

Decals and Instruction Plates, 0052 00-1
 Air Filter Housing, 0052 00-4
 Driver's Area, 0052 00-3
 Engine Oil Check and Fill Door Engine
 Compartment, 0052 00-8
 Fuel Control Valves, 0052 00-2
 Hose Connection Panel, 0052 00-7
 Hydraulic Control Valve Panel, 0052 00-1
 Refuel/Defuel Compartment, 0052 00-5, 0052 00-6
 Deep Water Fording Kit, 0005 00-14
 Description and Use of Operator's Controls and
 Indicators, 0006 00-1

Commander's Controls and Indicators, 0008 00-1
 Mechanic's Controls and Indicators, 0007 00-1

Destruction of Army Material to Prevent Enemy Use,
 0001 00-1
 Driving the Vehicle, 0016 00-1
 Driver's Viewer Enhancer, Operate, 0060 00-1

E

Engine Prestart Operation, 0011 00-1
 Engine Troubleshooting, 0090 00-1
 Equipment Characteristics, Capabilities and Features,
 0002 00-1
 Equipment Description
 Equipment Characteristics, Capabilities and
 Features, 0002 00-1
 Equipment Data, 0004 00-1
 Location and Description of Major Components,
 0003 00-1
 Exhaust System, 0005 00-4
 Extreme Cold Weather Maintenance, 0123 00-1
 Extreme Hot Weather Maintenance, 0124 00-1
 Extreme Hot Weather Operation, 0081 00-1
 General Information, 0081 00-1
 Operation of Hydraulic System, 0081 00-1

F

Fixed Fire Extinguisher Operation, 0062 00-1
 Fixed Fire Extinguisher System (FES), 0005 00-6
 Fording, 0083 00-1
 After Fording Operations, 0083 00-2
 Before Fording, 0083 00-1
 Deep Water Fording, 0083 00-1

G

Gas-Particulate Filter Unit, 0129 00-1
 Gas-Particulate Filter Unit Operation, 0068 00-1
 General Information
 Corrosion Prevention and Control, 0001 00-1
 Destruction of Army Materiel to Prevent Enemy Use,
 0001 00-1
 Hand Receipt (HR) Manuals, 0001 00-1
 List of Abbreviations, 0001 00-2
 Maintenance Forms and Procedures, 0001 00-1
 Nomenclature Cross-Reference List, 0001 00-2
 Reporting Equipment Improvement
 Recommendation (EIR), 0001 00-1
 Scope, 0001 00-1
 Warranty Information, 0001 00-1

ALPHABETICAL INDEX - CONTINUED

H

Hand Receipt (HR) Manuals, 0001 00-1
 Hoist Winch Operation, 0048 00-1
 Hydraulic Systems, 0005 00-7

I

Impact Wrench Operation, 0055 00-1
 Initial Adjustments, Checks, and Self-Test, 0010 00-1
 Instrument, Dome and Blackout Marker Lights, 0118 00-1

L

Liquid Chemical Agent Decontamination, 0084 00-1
 List of Abbreviations, 0001 00-2
 Location and Description of Major Components, 0003 00-1
 Lockout Blocks, 0047 00-14
 Lowering Boom, 0047 00-12
 Lubrication Instructions
 Capacities, 0105 00-73
 Lubricants, 0105 00-73
 Lubrication Order
 Daily, 0105 00-74
 Monthly, 0105 00-90
 Oil Can Points, 0105 00-108
 Quarterly, 0105 00-92

M

M239 Smoke Grenade System Operation, 0071 00-1
 Main Winch Operation, 0050 00-1
 Maintenance After Fording, 0125 00-1
 Maintenance After Operation on Unusual Terrain, 0126 00-1
 Maintenance Forms and Procedures, 0001 00-1
 Maintenance Forms and Records, 0105 00-1
 Maintenance of Auxiliary Equipment
 Caliber .50 Machine Gun and Mount, 0127 00-1
 Communications System, 0130 00-1
 Gas-Particulate Filter Unit, 0129 00-1
 M239 Smoke Grenade System, 0131 00-1
 Welding Equipment, 0128 00-1
 Maintenance Procedures
 Air Cleaners, 0116 00-1

Instrument, Dome and Blackout Marker Lights, 0118 00-1

Maintenance Under Unusual Conditions
 Extreme Cold Weather Maintenance, 0123 00-1
 Extreme Hot Weather Maintenance, 0124 00-1
 Maintenance After Fording, 0125 00-1
 Maintenance After Operation on Unusual Terrain, 0126 00-1
 Opening, Removal, Installation and Closing of Armor Skirt Panels, 0106 00-1
 Opening, Removal, Installation and Closing of Armor Skirt Panels with Quick-Release Pin, 0107 00-1
 Refueling, 0121 00-1
 Release Track Tension, 0110 00-1, 0111 00-1
 Track Installation, 0115 00-1
 Track Removal, 0114 00-1
 Track Shoe Replacement, 0113 00-1
 Vision Devices, 0119 00-1

Mechanic's Controls and Indicators, 0007 00-1

N

Nomenclature Cross-Reference List, 0001 00-2
 Nuclear Decontamination, 0084 00-1
 Nuclear, Biological and Chemical (NBC) Decontamination, 0084 00-1

O

Opening, Removal, Installation and Closing of Armor Skirt Panels, 0106 00-1
 Opening, Removal, Installation and Closing of Armor Skirt Panels with Quick-Release Pin, 0107 00-1
 Operate APU Compartment Door, 0030 00-1
 Operate Auxiliary Boom, 0039 00-1
 Operate Auxiliary Winch, 0049 00-1
 Operate Boom, 0047 00-1
 Operate Caliber .50 Machine Gun Mount, 0069 00-1
 Operate Communications System, 0070 00-1
 Operate Dome Light, 0021 00-1
 Operate Driver's Viewer Enhancer, 0060 00-1
 Operate Engine Deck Door, 0031 00-1
 Operate Engine Deck Side Grille, 0034 00-1, 0035 00-1
 Operate Fixed Fire Extinguisher, 0062 00-1
 Operate Front Engine Deck Grille, 0033 00-1
 Operate Fuel Control Valves, 0020 00-1
 Operate Gas-Particulate Filter Unit, 0068 00-1
 Operate Hoist Winch, 0048 00-1
 Operate Hoist Winch Cable Access Door, 0029 00-1

ALPHABETICAL INDEX - CONTINUED

- Operate Hull and Crew Compartment Doors, Grilles, and Access Panels, 0024 00-1
- Operate Impact Wrench, 0055 00-1
- Operate Light Switch Assembly, 0023 00-1
- Operate M239 Smoke Grenade System, 0071 00-1
- Operate Main Winch, 0050 00-1
- Operate Operator's, Mechanic's, and Personnel Hatch, 0026 00-1
- Operate Outside Spotlight, 0064 00-1
- Operate Passive Night Viewer AN/VVS-2(V)1A Operation, 0059 00-1
- Operate Personnel Heater, 0056 00-1
- Operate Personnel Heater Global (A20), 0057 00-1
- Operate Pintle, 0042 00-1
- Operate Portable Fire Extinguisher, 0061 00-1
- Operate Rear Service Lights, 0022 00-1
- Operate Spade, 0046 00-1
- Operate Storage Compartment Door, Right Side Hull, 0028 00-1
- Operate Subfloor Access Plates and Doors, 0036 00-1
- Operate Tow Bar, 0043 00-1
- Operate Tow Cable, 0044 00-1
- Operate Trouble Light, 0065 00-1
- Operate Vehicle Jack, 0063 00-1
- Operate Ventilating Blower, 0058 00-1
- Operate Welding Equipment
 - Acetylene/Oxygen, 0067 00-1
 - Exothermic Cutter, 0067 00-1
- Operating Procedures, Auxiliary Equipment Operation, 0053 00-1
- Operation Under Unusual Conditions
 - Extreme Cold Weather Operation, 0076 00-1
 - Extreme Cold Wether Operation
 - Parking Vehicle, 0078 00-1
 - Starting the Auxiliary Power Unit (APU), 0079 00-1
 - Extreme Hot Weather Operation, 0081 00-1
 - General Information, 0081 00-1
 - Operation of Hydraulic System, 0081 00-1
 - Fording, 0083 00-1
 - After Fording Operation, 0083 00-2
 - Deep Water Fording, 0083 00-1
 - Nuclear, Biological and Chemical (NBC) Decontamination
 - Emergency Procedures, 0084 00-1
 - Biological Decontamination, 0084 00-1
 - Liquid Chemical Agent Decontamination, 0084 00-1
 - Nuclear Decontamination, 0084 00-1
 - External Decontamination, 0084 00-3
 - General, 0084 00-1
- Operating Procedures
 - Adjust Operator's and Mechanic's Seat, 0037 00-1
 - Adjusting Commander's Seat, 0038 00-1
 - Operate Engine Deck Access Door, 0035 00-1, 0036 00-1
 - Operate Engine Deck Side Grille, 0034 00-1
 - Parking Vehicle in Extreme Cold Weather Operation, 0078 00-1
 - Starting Auxiliary Power Unit in Extreme Cold Weather Operation, 0079 00-1, 0080 00-1
 - Starting Main Engine in Extreme Cold Weather Operation, 0077 00-1
 - Unusual Terrain Operation, 0082 00-1
 - Ice, 0082 00-1
 - Mud, 0082 00-1
 - Sand, 0082 00-1
 - Snow, 0082 00-1
- Operation Under Usual Conditions
 - Assembly and Preparation for Use, 0010 00-1
 - Initial Adjustments, Checks, and Self-Test, 0010 00-1
 - Operating Procedures, Operate Front Engine Deck Grille, 0033 00-1
 - Operating Hull and Crew Compartment Doors, Grilles and Access Panels, Commander's Cupola, 0025 00-1
 - Operating Procedures
 - Auxiliary Boom Operation, 0039 00-1
 - Auxiliary Winch Operation, 0049 00-1
 - Boom Operation, 0047 00-1
 - Decals and Instruction Plates, 0052 00-1
 - Air Filter Housing, 0052 00-4
 - AN/VIC-3(V) Vehicle Intercommunication System (VIS), 0052 00-6
 - Driver's Area, 0052 00-3
 - Engine Oil Check and Fill Door Engine Compartment, 0052 00-8
 - Fuel Control Valves, 0052 00-2
 - Hose Connection Panel, 0052 00-7
 - Hydraulic Control Valve Panel, 0052 00-1
 - Refuel/Defuel Compartment, 0052 00-5
 - Drive the Vehicle
 - Driving Down Steep Grades Backward with Transmission in 1st Gear, 0016 00-3
 - Driving Down Steep Grades Forward with Transmission in Reverse, 0016 00-3
 - Driving Over Rough, Soft, or Hilly Terrain, 0016 00-2
 - Normal, 0016 00-2
 - Engine Prestart Operation, 0011 00-1
 - Hoist Winch Operation, 0048 00-1
 - Main Winch Operation, 0050 00-1

ALPHABETICAL INDEX - CONTINUED

- Operate Storage Compartment Door, Left Side Hull, 0027 00-1
- Operate Storage Compartment Door, Right Side Hull, 0028 00-1
- Operate APU Compartment Door, 0030 00-1
- Operate Auxiliary Boom, 0039 00-1
- Operate Auxiliary Equipment
 - Caliber .50 Machine Gun Mount Operation, 0069 00-1
 - Communications System Operation, 0070 00-1
 - Fixed Fire Extinguisher Operation, 0062 00-1
 - Gas-Particulate Filter Unit Operation, 0068 00-1
 - Impact Wrench Operation, 0055 00-1
 - M239 Smoke Grenade System Operation, 0071 00-1
 - Auxiliary Power Unit Operation, 0053 00-1
 - Operate Caliber .50 Machine Gun Mount, 0069 00-1
 - Operate Communications System, 0070 00-1
 - Operate Fixed Fire Extinguisher, 0062 00-1
 - Operate Gas-Particulate Filter Unit, 0068 00-1
 - Operate Impact Wrench, 0055 00-1
 - Operate M239 Smoke Grenade System, 0071 00-1
 - Operate Outside Spotlight, 0064 00-1
 - Operate Passive Night Viewer AN-VVS-2(V)1A, 0059 00-1
 - Operate Personnel Heater, 0056 00-1
 - Operate Personnel Heater Global (A20), 0057 00-1
 - Operate Portable Fire Extinguisher, 0061 00-1
 - Operate Trouble Light, 0065 00-1
 - Operate Vehicle Jack, 0063 00-1
 - Operate Ventilating Blower, 0058 00-1
 - Outside Spotlight Operation, 0064 00-1
 - Passive Night Viewer AN-VVS-2(V)1A Operation, 0059 00-1
 - Personnel Heater Operation, 0056 00-1
 - Personnel Heater Operation Global (A20), 0057 00-1
 - Portable Fire Extinguisher Operation, 0061 00-1
 - Refuel and Defuel Operation, 0054 00-1
 - Trouble Light Operation, 0065 00-1
 - Vehicle Jack Operation, 0063 00-1
 - Ventilating Blower Operation, 0058 00-1
 - Welding Equipment (Acetylene/Oxygen), 0066 00-1
 - Welding Equipment (Exothermic Cutter), 0067 00-1
- Operate Auxiliary Winch, 0049 00-1
- Operate Boom, 0047 00-1
 - Lockout Blocks, 0047 00-14
- Operate Dome Light, 0021 00-1
- Operate Engine Deck Door, 0031 00-1
- Operate Fuel Control Valves, 0020 00-1
- Operate Hoist Winch, 0048 00-1
- Operate Hoist Winch Cable Access Door, 0029 00-1
- Operate Hull and Crew Compartment Doors, Grilles, and Access Panels, 0024 00-1
- Operate Light Switch Assembly, 0023 00-1
- Operate Main Winch, 0050 00-1
- Operate Operator's, Mechanic's, and Personnel Hatch, 0026 00-1
- Operate Rear Service Lights, 0022 00-1
- Operate Spade, 0046 00-1
- Operate Storage Compartment Door, Left Side Hull, 0027 00-1
- Operate Tow Bar, 0043 00-1
- Operate Tow Cable, 0044 00-1
- Operate Pintle, 0042 00-1
- Pintle Operation, 0042 00-1
- Preparation for Movement, 0073 00-1
- Preparing the Hydraulic System for Operation, 0045 00-1
- Starting the Main Engine, 0012 00-1
 - Slave Start, 0074 00-1
 - Towed Start, 0075 00-1
- Stop the Vehicle, 0017 00-1
- Tow Bar Operation, 0043 00-1
- Tow Cable Operation, 0044 00-1
- Tow Disabled Vehicle, 0041 00-1
- Towing Operation, 0040 00-1
- Transmission Shift Selection, 0014 00-1
- Vehicle Recovery Operations, 0051 00-1
- Operating Procedures, Operate Boom, Lowering Boom, 0047 00-12
- Outside Spotlight Operation, 0064 00-1

P

- Parking Vehicle, 0078 00-1
- Passive Night Viewer AN/VVS-2(V)1A Operation, 0059 00-1
- Personnel Heater Operation, 0056 00-1
- Personnel Heater Operation Global (A20), 0057 00-1
- Pintle Operation, 0042 00-1
- Portable Fire Extinguisher Operation, 0061 00-1
- Powerpack, 0005 00-1
- Preparation for Movement, 0073 00-1
- Preparing the Hydraulic System for Operation, 0045 00-1
- Preventive Maintenance Checks and Services, 0105 00-1
 - Maintenance Forms and Records, 0105 00-1
 - Preventive Maintenance Checks and Services, 0105 00-1
 - Things to Remember While Doing PMCS, 0105 00-2
- Track and Suspension, 0005 00-5

ALPHABETICAL INDEX - CONTINUED

R

References

- Field Manuals, 0132 00-1
- Forms, 0132 00-1
- Military Specifications, 0132 00-3
- Miscellaneous Publications, 0132 00-4
- Regulations, 0132 00-3
- Technical Bulletins, 0132 00-2
- Refuel and Defuel Operation, 0054 00-1
- Refueling, 0121 00-1
- Release Track Tension (New Configuration), 0111 00-1
- Release Track Tension (Old Configuration), 0110 00-1
- Reporting Equipment Improvement Recommendation, 0001 00-1

S

- Scope, 0001 00-1
- Service Auxiliary Power Unit cleaner, 0117 00-1
- Servicing Turbo Dust Detector, 0120 00-1
- Shutdown Main Engine, 0019 00-1
- Slave Start, 0074 00-1
- Smoke Grenade Launcher System, M239, 0005 00-13
- Starting Main Engine, 0012 00-1
- Starting Main Engine in Cold Weather, 0077 00-1
- Starting the Auxiliary Power Unit, 0079 00-1
- Steering Instructions, 0015 00-1
- Stop the Vehicle, 0017 00-1
- Stowage and Sign Guide
 - Stencil and Label Locations (Hull Interior), 0136 00-5
 - Stencil Locations (Hull Exterior), 0136 00-2
 - Stowed Items Location Index (Exterior), 0136 00-9
 - Stowed Items Location Index (Interior), 0136 00-13

T

- Theory of Operation, 0005 00-1
 - Air Intake System, 0005 00-3
 - Air Purification System, 0005 00-12
 - Auxiliary Power Unit, 0005 00-10, 0005 00-11
 - Cooling System, 0005 00-2
 - Deep Water Fording Kit, 0005 00-14
 - Exhaust System, 0005 00-4
 - Fixed Fire Extinguisher System (FES), 0005 00-6

- Hydraulic Systems, 0005 00-7
- Powerpack, 0005 00-1
- Smoke Grenade Launcher System, M239, 0005 00-13
- Track and Suspension, 0005 00-5
- Things to Remember While Doing PMCS, 0105 00-2
- Tow Bar Operation, 0043 00-1
- Tow Cable Operation, 0044 00-1
- Tow Disabled Vehicle, 0041 00-1
- Towed Start, 0075 00-1
- Towing Operation, 0040 00-1
- Towed Start, 0075 00-1
- Track Adjusting Link Grease Fitting Replacement, 0112 00-1
- Track and Suspension, 0005 00-5
- Track Installation, 0115 00-1
- Track Removal, 0114 00-1
- Track Shoe Replacement, 0113 00-1
- Track Tension Adjustment (New Configuration), 0109 00-1
- Track Tension Adjustment (Old Configuration), 0108 00-1
- Transmission Shift Selection, 0014 00-1
- Trouble Light Operation, 0065 00-1
- Turbo Dust Detector Maintenance, 0120 00-1

U

- Unusual Terrain Operation, 0082 00-1
 - Ice, 0082 00-1
 - Mud, 0082 00-1
 - Sand, 0082 00-1
 - Snow, 0082 00-1

V

- Vehicle Jack Operation, 0063 00-1
- Vehicle Recovery Operations, 0051 00-1
- Ventilating Blower Operation, 0058 00-1
- Vision Devices, 0119 00-1

W

- Warranty Information, 0001 00-1
- Welding Equipment, 0066 00-1, 0067 00-1

RECOMMENDED CHANGES TO PUBLICATIONS AND BLANK FORMS For use of this form, see AR 25-30; the proponent agency is ODISC4.					Use Part II (<i>reverse</i>) for Repair Parts and Special Tools Lists (RPSTL) and Supply Catalogs/Supply Manuals (SC/SM).		Date
TO: (<i>Forward to proponent of publication or form</i>) (<i>Include ZIP Code</i>)					FROM: (<i>Activity and location</i>) (<i>include ZIP code</i>)		
PART I – ALL PUBLICATIONS (EXCEPT RPSTL AND SC/SM) AND BLANK FORMS							
PUBLICATION/FORM NUMBER TM 9-2350-292-10				DATE 1 NOVEMBER 2005		TITLE OPERATOR MANUAL FOR M88A2 HEAVY RECOVERY VEHICLE	
ITEM	PAGE	PARA	LINE	FIGURE NO.	TABLE	RECOMMENDED CHANGES AND REASON	
0102 00-3						Removal step 2 WP reference should be (WP 0039 00).	
*Reference to line numbers within the paragraph or subparagraph.							
TYPED NAME, GRADE OR TITLE				TELEPHONE EXCHANGE/AUTOVON, PLUS EXTENSION		SIGNATURE	

TO: <i>(Forward direct to addressee listed in publication)</i>	FROM: <i>(Activity and location) (Include Zip Code)</i>	DATE
--	---	------

PART II - REPAIR PARTS AND SPECIAL TOOL LISTS AND SUPPLY CATALOGS/SUPPLY MANUALS

PUBLICATION NUMBER	DATE	TITLE
--------------------	------	-------

PAGE NO.	COLM NO.	LINE NO.	NATIONAL STOCK NUMBER	REFERENCE NO.	FIGURE NO.	ITEM NO.	TOTAL NO. OF MAJOR ITEMS SUPPORTED	RECOMMENDED ACTION

PART III - REMARKS *(Any general remarks or recommendations, or suggestions for improvement of publications and blank forms. Additional blank sheets may be used if more space is needed.)*

SAMPLE

TYPED NAME, GRADE OR TITLE	TELEPHONE EXCHANGE/AUTOVON, PLUS EXTENSION	SIGNATURE
----------------------------	--	-----------

RECOMMENDED CHANGES TO PUBLICATIONS AND BLANK FORMS For use of this form, see AR 25-30; the proponent agency is ODISC4.					Use Part II (<i>reverse</i>) for Repair Parts and Special Tools Lists (RPSTL) and Supply Catalogs/Supply Manuals (SC/SM).		Date
TO: (<i>Forward to proponent of publication or form</i>) (<i>Include ZIP Code</i>)					FROM: (<i>Activity and location</i>) (<i>include ZIP code</i>)		
PART I – ALL PUBLICATIONS (EXCEPT RPSTL AND SC/SM) AND BLANK FORMS							
PUBLICATION/FORM NUMBER TM 9-2350-292-10				DATE 1 NOVEMBER 2005		TITLE OPERATOR MANUAL FOR M88A2 HEAVY RECOVERY VEHICLE	
ITEM	PAGE	PARA	LINE	FIGURE NO.	TABLE	RECOMMENDED CHANGES AND REASON	
*Reference to line numbers within the paragraph or subparagraph.							
TYPED NAME, GRADE OR TITLE				TELEPHONE EXCHANGE/AUTOVON, PLUS EXTENSION		SIGNATURE	

TO: <i>(Forward direct to addressee listed in publication)</i>	FROM: <i>(Activity and location) (Include Zip Code)</i>	DATE
--	---	------

PART II - REPAIR PARTS AND SPECIAL TOOL LISTS AND SUPPLY CATALOGS/SUPPLY MANUALS

PUBLICATION NUMBER	DATE	TITLE
--------------------	------	-------

PAGE NO.	COLM NO.	LINE NO.	NATIONAL STOCK NUMBER	REFERENCE NO.	FIGURE NO.	ITEM NO.	TOTAL NO. OF MAJOR ITEMS SUPPORTED	RECOMMENDED ACTION

PART III - REMARKS *(Any general remarks or recommendations, or suggestions for improvement of publications and blank forms. Additional blank sheets may be used if more space is needed.)*

--

TYPED NAME, GRADE OR TITLE	TELEPHONE EXCHANGE/AUTOVON, PLUS EXTENSION	SIGNATURE
----------------------------	--	-----------

By Order of the Secretary of the Army:

PETER J. SCHOOMAKER
General, United States Army
Chief of Staff

Official:

A handwritten signature in black ink that reads "Sandra R. Riley". The signature is written in a cursive style with a large, looping 'S' and 'R'.

SANDRA R. RILEY
Administrative Assistant to the
Secretary of the Army
0527224

DISTRIBUTION: To be distributed in accordance with the Initial Distribution Number (IDN) 372405, requirements for TM 9-2350-292-10.

CONVERSION TABLE

inch	decimal	mm	inch	decimal	mm	inch	decimal	mm
1/64	0.015625	0.3969	23/64	0.359375	9.1281			
1/32	0.031250	0.7938	3/8	0.375000	9.5250	45/64	0.703125	17.8594
3/64	0.046875	1.1906				23/32	0.718750	18.2562
1/16	0.062500	1.5875	25/64	0.390625	9.9219	47/64	0.734375	18.6531
			13/32	0.406250	10.3188	3/4	0.750000	19.050
5/64	0.078125	1.9844	27/64	0.421875	10.7156			
3/32	0.093750	2.3812	7/16	0.437500	11.1125	49/64	0.765625	19.4469
7/64	0.109375	2.7781				25/32	0.781250	19.8437
1/8	0.125000	3.1750	29/64	0.453125	11.5094	51/64	0.796875	20.2406
			15/32	0.468750	11.9062	13/16	0.812500	20.6375
9/64	0.140625	3.5719	31/64	0.484375	12.3031			
5/32	0.156250	3.9688	1/2	0.500000	12.7000	53/64	0.828125	21.0344
11/64	0.171875	4.3656				27/32	0.843750	21.4312
3/16	0.187500	4.7625	33/64	0.515625	13.0969	55/64	0.859375	21.8281
			17/32	0.531250	13.4938	7/8	0.875000	22.2250
13/64	0.203125	5.1594	35/64	0.546875	13.8906			
7/32	0.218750	5.5562	9/16	0.562500	14.2875	57/64	0.890625	22.6219
15/64	0.234375	5.9531				29/32	0.906250	23.0188
1/4	0.250000	6.3500	37/64	0.578125	14.6844	59/64	0.921875	23.4156
			19/32	0.593750	15.0812	15/16	0.937500	23.8125
17/64	0.265625	6.7469	39/64	0.609375	15.4781			
9/32	0.281250	7.1438	5/8	0.625000	15.8750	61/64	0.953125	24.2094
19/64	0.296875	7.5406				31/32	0.967500	24.6062
5/16	0.312500	7.9375	41/64	0.640625	16.2719	63/64	0.984375	25.0031
			21/32	0.656250	16.6688			
21/64	0.328125	8.3344	43/64	0.671875	17.0656	1	1.000000	25.4000
11/32	0.343750	8.7312	11/16	0.687500	17.4625			

THE METRIC SYSTEM AND EQUIVALENTS

LINEAR MEASURE

1 Centimeter = 10 Millimeters = 0.01 Meters = 0.3937 Inches
 1 Meter = 100 Centimeters = 1000 Millimeters = 39.37 Inches
 1 Kilometer = 1000 Meters = 0.621 Miles

WEIGHTS

1 Gram = 0.001 Kilograms = 1000 Milligrams = 0.035 Ounces
 1 Kilogram = 1000 Grams = 2.2 Lb.
 1 Metric Ton = 1000 Kilograms = 1 Megagram = 1.1 Short Tons

LIQUID MEASURE

1 Milliliter = 0.001 Liters = 0.0338 Fluid Ounces
 1 Liter = 1000 Milliliters = 33.82 Fluid Ounces

SQUARE MEASURE

1 Sq. Centimeter = 100 Sq. Millimeters = 0.155 Sq. Inches
 1 Sq. Meter = 10,000 Sq. Centimeters = 10.76 Sq. Feet
 1 Sq. Kilometer = 1,000 Sq. Meters = 0.386 Sq. Miles

CUBIC MEASURE

1 Cu. Centimeter = 1000 Cu. Millimeters = 0.06 Cu. Inches
 1 Cu. Meter = 1,000,000 Cu. Centimeters = 35.31 Cu. Feet

TEMPERATURE

$5/9 (^{\circ}\text{F} - 32) = ^{\circ}\text{C}$
 212° Fahrenheit is equivalent to 100° Celcius
 90° Fahrenheit is equivalent to 32.2° Celcius
 32° Fahrenheit is equivalent to 0° Celcius
 $(9/5 \times ^{\circ}\text{C}) + 32 = ^{\circ}\text{F}$

APPROXIMATE CONVERSION FACTORS

TO CHANGE	TO	MULTIPLY BY
Inches	Centimeters	2.540
Feet	Meters	0.305
Yards	Meters	0.914
Miles	Kilometers	1.609
Square Inches	Square Centimeters	6.451
Square Feet	Square Meters	0.093
Square Yards	Square Meters	0.836
Square Miles	Square Kilometers	2.590
Acres	Square Hectometers	0.405
Cubic Feet	Cubic Meters	0.028
Cubic Yards	Cubic Meters	0.765
Fluid Ounces	Millimeters	29.573
Pints	Liters	0.473
Quarts	Liters	0.946
Gallons	Liters	3.785
Ounces	Grams	28.349
Pounds	Kilograms	0.454
Short Tons	Metric Tons	0.907
Pound-Feet	Newton-Meters	1.356
Pounds per Square Inch	Kilopascals	6.895
Miles per Gallon	Kilometers per Liter	0.425
Miles per Hour	Kilometers per Hour	1.609

TO CHANGE	TO	MULTIPLY BY
Centimeters	Inches	0.394
Meters	Feet	3.280
Meters	Yards	1.094
Kilometers	Miles	0.621
Square Centimeters	Square Inches	0.155
Square Meters	Square Feet	10.764
Square Meters	Square Yards	1.196
Square Kilometers	Square Miles	0.386
Square Hectometers	Acres	2.471
Cubic Meters	Cubic Feet	35.315
Cubic Meters	Cubic Yards	1.308
Milliliters	Fluid Ounces	0.034
Liters	Pints	2.113
Liters	Quarts	1.057
Liters	Gallons	0.264
Grams	Ounces	0.035
Kilograms	Pounds	2.205
Metric Tons	Short Tons	1.102
Newton-Meters	Pound-Feet	0.738
Kilopascals	Pounds per Square Inch	0.145
Kilometers per Liter	Miles per Gallon	2.354
Kilometers per Hour	Miles per Hour	0.621

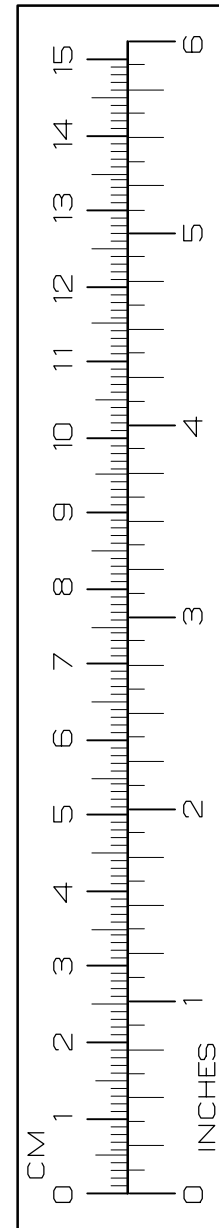

PIN: 076591-000